



## PRODUCT SPECIFICATION

# HE-5

## B-PLUS™ SERIES PACKAGED WATER HEATERS

### GENERAL DESCRIPTION

The AERCO B-PLUS™ heater is a compact, totally packaged steam-to-water heater designed for easy heater selection, ease of installation, long service life, and minimum maintenance.

### PRINCIPLES OF OPERATION

The B-PLUS™ heater utilizes a series of free-floating modular helical coils mounted vertically on a steam riser with steam inside the coils and domestic water in the shell.

Cold water enters at the bottom and passes upward over the coils, exiting at the top of the heater at the desired temperature.

The outlet temperature is maintained to within  $\pm 4^\circ\text{F}$  of set point by AERCO's exclusive Feed Forward Temperature Control System.

### FEATURES

- Completely Packaged.** The B-PLUS™ heater package includes the heat exchanger and pneumatic or self-contained steam valve (as specified), double-solenoid temperature limit system, temperature and pressure gauges, temperature and pressure relief valves, "ON" and "TRIPPED" system status indicators, union orifice, drain valve, condensate check valve, thermal insulation, and outer shell.
- Free Floating Coils.** The heat exchanger is comprised of a series of modular, individually replaceable free-floating copper helical coils. The coils provide maximum turbulence within the heater with no stresses at points of connection, and no need for baffles. The B-PLUS™ Heater can be used with either high pressure or low pressure steam.
- Automatic Descaling.** With steam inside the coils and domestic water in the shell, any scale that forms on the outside of the coils is removed automatically as the coils flex with changes in temperature. Scale settles to the bottom of the heater where it can be drained without disassembling the heater.
- Accurate Temperature Control.** The B-PLUS™ Heater is equipped with AERCO's exclusive integral demand anticipator which continuously monitors water temperature and flow and modulates the flow of steam through the valve and into the coils, thereby maintaining the preset outlet temperature to within  $\pm 4^\circ\text{F}$ , even under fluctuating loads.
- Automatic Sub-Cooling of Condensate.** Steam enters the steam riser and flows in parallel through the coils, condensing as the cold water flows upward over the coils. The sub-cooled condensate is collected in the condensate riser and drains from the bottom of the heater.
- All Non-Ferrous Wetted Parts.** B-PLUS™ heaters are constructed to ASME Boiler and Pressure Vessel Code Section VIII, with a 235 PSI rated shell and 250 PSI rated coils. All wetted parts are copper or bronze. These include copper heat exchanger coils, cast bronze heads, and solid copper shell lining.
- 10-Year Extended Warranty.** In addition to the standard one-year manufacturer's warranty on materials and construction, AERCO offers a low-cost non-prorated Extended 10-year Warranty which covers the complete heat exchanger, pressure vessel, and integral demand anticipator.
- Space Efficient Design.** AERCO's exclusive vertical heater design results in a compact unit that takes up only four square feet of floor space, about 1/10 the space of a storage heater designed for comparable service. The B-PLUS™ heater fits through a standard doorway for easy installation.



- Hospitals • Industrial Plants
- Restaurants • Marine
- Laundries • Universities
- Hotels • Apartment Houses

# B-PLUS™ SERIES PACKAGED WATER HEATERS

## Dimensions & Data

Inches (Metric)

### NOMENCLATURE KEY

SWIB+					
Number of Coils		Valve Size		Valve Type	
3	03	1.00	1" (25.4)	P	Pneumatic
5	05	1.25	1.25" (31.75)	S	Self-Cont.
7	07	1.50	1.50" (38.10)		
9	09	2.00	2.00" (50.80)		
11	11	2.50	2.50" (63.50)		
13	13	3.00	3.00" (76.20)		
15	15	4.00	4.00" (101.60)		

### DIMENSIONS—WEIGHTS

Heater Size No. of Coils	Dimension A Inches (M)	Weight Lbs. (Kg.)
SW1B + 03	55 (1.40 )	460 (210)
SW1B + 05	64 (1.625)	550 (250)
SW1B + 07	73 (1.854)	610 (277)
SW1B + 09	82 (2.083)	680 (308)
SW1B + 11	91 (2.311)	740 (336)
SW1B + 13	100 (2.540)	810 (367)
SW1B + 15	109 (2.769)	870 (395)

### HEAT EXCHANGER DESIGN STANDARDS

PART	Max. Working Pressure PSIG (kPa)	Max. Temp. °F (°C)	Test Pressure PSIG (kPa)
Shell	235 (1619)	400 (204)	355 (2446)
Tube	250 (1723)	400 (204)	375 (2584)

ASME Code Certification Stamp U-7

PART	MATERIALS OF CONSTRUCTION
Shell	Carbon Steel SA414 or SA285 G.R.C.
Rings	Steel ASME SA675 GRADE 55
End	Bronze SB62
Liner	Copper ASTM B152 Type ETP, .024" (.61) Thick
Coils	Copper 0.049" Wall SB111

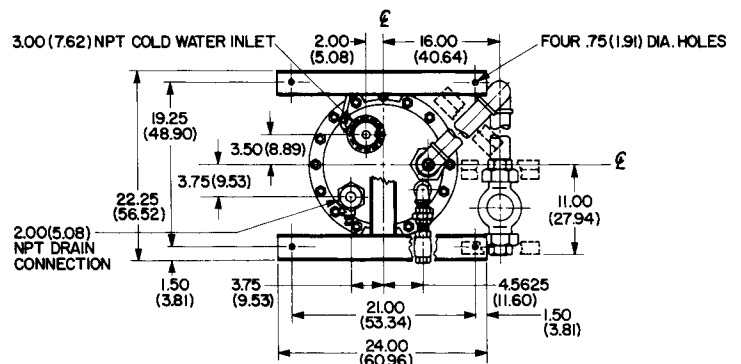
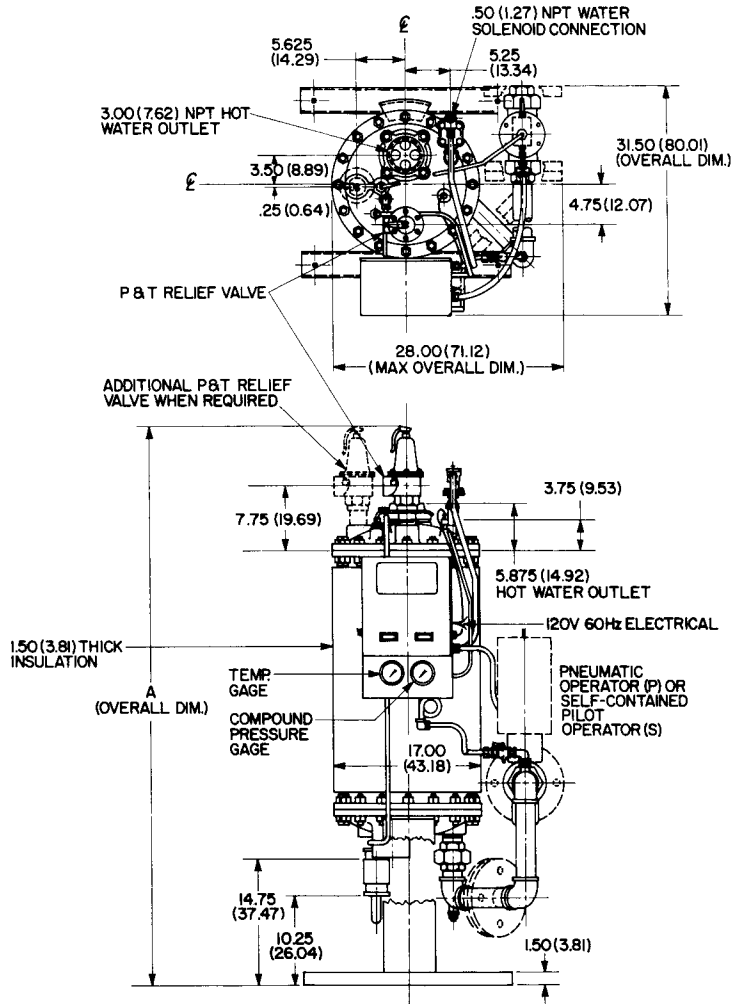

Dimensions are subject to change.  
 Certified drawings are available on request.

# B-PLUS™ SERIES PACKAGED WATER HEATERS

- 1 **Temperature/Pressure Relief Valve**  
—Pressure Relief setting, 150 PSIG  
Temperature Relief Setting, 210° F
- 2 **Hot Water Outlet**
- 3 **Pneumatic (or Self-Contained) Steam Valve**  
—Modulates Steam to Coils for Accurate  
Temperature Control
- 4 **Sub-Cooled Condensate Outlet**  
—No Condensate Traps • No Flash Loss  
• No Mixing of Condensate With Cold Water  
• Longer Condensate Pump Life • Up to  
15% Savings in Steam Used
- 5 **Cold Water Inlet**
- 6 **Temperature and Pressure Gauges**  
—Accurate Temperature and Pressure Indication
- 7 **(Green) "ON" and (Red) "TRIPPED" Status Indicators**

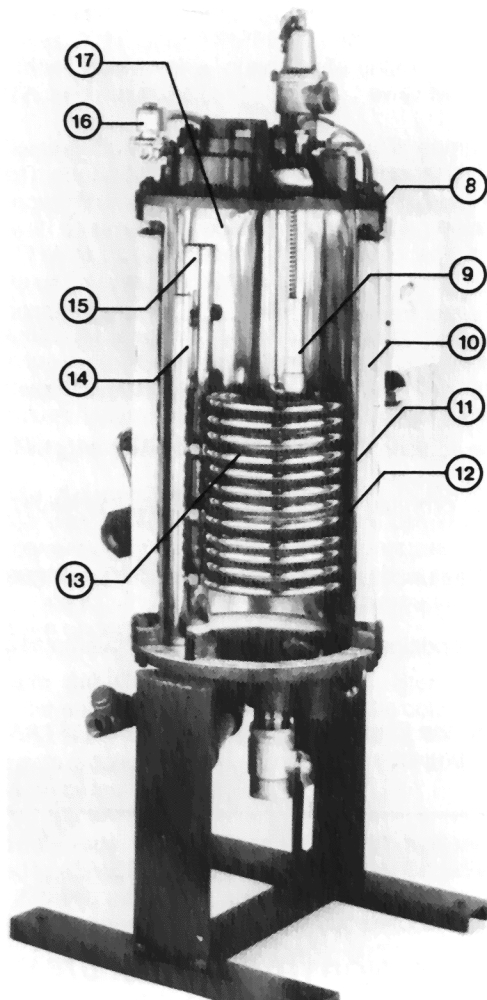
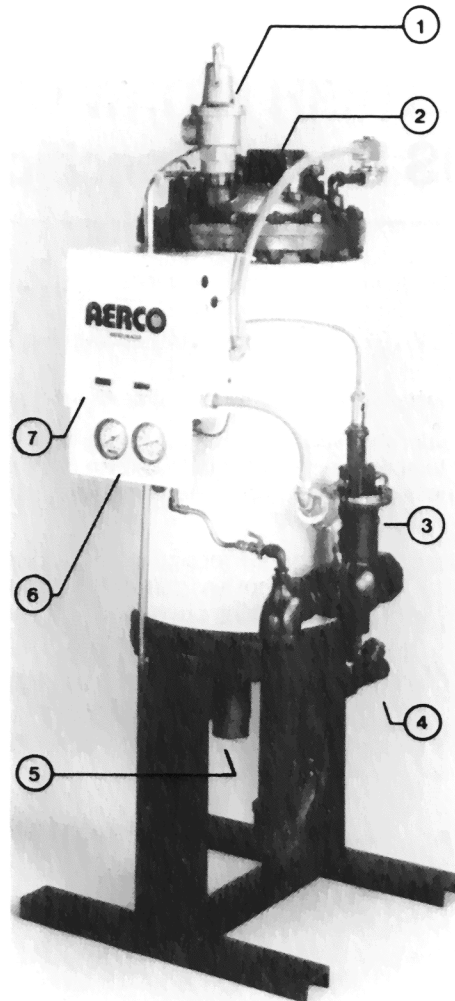

- 8 **Cast Bronze Heads**  
—Minimize Corrosion for Long Life
- 9 **Feed Forward Temperature Control System**  
—Maintains Preset Outlet Temperature to within  
 $\pm 4^{\circ}$  F
- 10 **Thermal Insulation**
- 11 **ASME Coded Steel Pressure Vessel**  
—Rated at 235 PSI working pressure
- 12 **Solid Copper Shell Liner**  
—For maximum corrosion resistance
- 13 **Modular, Free Floating Copper Coils**  
—Automatic Self-descaling • No baffles  
• ASME Coded Coils
- 14 **Condensate Riser**  
—Collects Sub-Cooled Condensate
- 15 **Steam Riser**  
—Delivers Steam to Coils
- 16 **Double Solenoid Temperature Limit System**
- 17 **Domestic Water in Shell**  
—Low Shell Temperatures

# B-PLUS™ SERIES PACKAGED WATER HEATERS

## B-PLUS Heater Specification

A. Furnish and install as shown on plans. \_\_\_\_\_ AERCO water heater(s),

Model SW1B+ \_\_\_\_/\_\_\_\_/\_\_\_\_, as manufactured by AERCO INTERNATIONAL INC., Northvale, NJ.

Each heater shall be of the vertical cross flow design with service water in the shell and steam in the coils.

The heater shall subcool the steam condensate. Condensate temperature shall not exceed 190° F when incoming domestic water temperature is 110° F or lower. An integral demand anticipator requiring no electrical hookup shall be provided, anticipating a change in demand so that the final temperature can be maintained to  $\pm 4^\circ$  F under all normal load conditions.

B. Certification of the unit as to design and manufacture in accordance with the ASME Pressure Vessel Code, Section VIII, Div. 1 shall be furnished for not less than 235 PSI maximum allowable working pressure in the shell, and not less than 250 PSI maximum allowable working pressure in the coils.

C. SHELL: shall be carbon steel with copper lining. Heads shall be bronze.

D. COILS: shall be helical wound copper tube (.049" wall). No water baffles or other supports shall be used within the shell. Coils shall provide automatic descaling due to expansion and contraction under varying primary fluid flow.

E. Each heater shall be factory packaged with the following accessories:

- Resilient insulation
- Pneumatic control valve and temperature controller or self-contained valve
- Temperature/pressure relief valve
- Union orifice and check valve
- Control panel featuring:
  - Double solenoid temperature limit safety system
  - Power on/tripped status lights
  - Remote dial thermometer and compound gauge

F. PERFORMANCE: Each heater shall be rated to heat: \_\_\_\_\_ GPM of water from \_\_\_\_\_° F to \_\_\_\_\_° F when supplied with \_\_\_\_\_ lbs./hr. of saturated steam at \_\_\_\_\_ PSIG to the control valve.

G. WARRANTY: The heat exchanger shall carry an extended warranty in addition to the manufacturer's warranty, as follows.

Coils—The heat exchanger coils shall carry an unconditional, non-prorated 10-year guarantee against failure due to thermal shock, mechanical failure, or erosion.

Pressure Vessel—The heat exchanger pressure vessel shall carry an unconditional, non-prorated 10-year guarantee against leakage due to internal corrosion.

Anticipator—The integral demand anticipator unit shall carry an unconditional, non-prorated 10-year guarantee against any failure.

Such warranty of the above listed items shall be supplied in writing to the Engineer by the manufacturer as part of the submittals and shall be honored by the manufacturer to the end user or project owner.

**AERCO INTERNATIONAL, INC., 159 PARIS AVENUE, NORTHVALE, N.J. 07647, USA**  
**PHONE: (201) 768-2400 TELEEX: 135450 FAX: 201-768-7789**