



# CSNX-XHE 102-402

"ROOF TOP" AIR COOLED HEAT PUMP FOR CROWDED ROOM

- REDUCED ENERGY CONSUMPTION
- COMPACT DIMENSIONS
- ENERGY RECOVERY STANDARD
- CONSTANT FLOW RATE CONTROL



## CSNX-XHE 102 - 402 (R-410A)

Size	Cooling [kW]	Heating [kW]
102	37.9	38.5
122	44.0	44.7
162	51.3	52.4
182	62.2	62.3
222	73.2	72.7
262	84.0	86.4
302	99.2	98.4
362	112	115
402	125	129

Performance refers to operation with 80% of expelled and outside air

Autonomous air conditioners of the CSNX-XHE series are developed by Clivet for all high attendance venues that require large quantity of fresh air. The units feature:

### IMMEDIATE AND SIMPLE ADJUSTMENT OF CONDITIONS OF WELL-BEING

The units can be easily programmed and managed by the user. The communications interface is simple and intuitive. The machine logics controls the resources automatically to ensure conditions of well-being.

### REDUCED OPERATING COSTS

The high efficiency of the innovative optimized refrigeration circuit for operation at partial load, free-cooling and free-heating, the recovery system on the expelled air, ventilation with plug fans coupled directly to DC brushless motors all combine to limit energy consumption and the operating costs of the system.

### EASE OF POSITIONING AND INSTALLATION

The units are exceptionally compact, perfect for positioning on especially crowded roofs. Attention to client needs and care for details has led to the creation of a machine that can be quickly installed and immediately commissioned.

REPLACE: BT08C001GB-00

BT08C001GB-02

## GENERAL DESCRIPTION

The CSNX-XHE units are perfect air conditioners for large and medium-size areas which are very crowded, such as convention halls, cinemas, theatres, restaurants, bars, discos, etc. They are especially designed to recirculate air in the room, treating high percentages of outside air (up to 80%).

The machines are autonomous, controlled by a microprocessor, and are able to:

- heat and humidify the air (winter treatment)
  - cool and de-humidify (summer treatment)
  - filter the air and check air quality
  - free-cooling in periods where conditions allow
- The units feature high efficiency of the refrigeration circuit at partial loads, high-yield plug fans and active energy recovery on the expelled air standard.

## VERSATILITY OF USE

The wide range of models and the possibility to choose the constructive configurations make it possible to select the product that is best suited to the needs of each installation and to integrate the unit into various architectonic contexts. The selection of accessories completes the possibility to customize the product according to the needs of the client.

## EXTREME COMPACTNESS

The original layout of the sections that make up the machine substantially reduces its footprint, making it easier to position and leaving more space available for parking, additional equipment rooms or other uses. This also reduces the time required for the positioning of the ducts on the various sides of the unit, since its great compactness allows its complete rotation (which is very difficult with traditional units with in-line extension).

## REDUCTION OF CONSUMPTION AND OPERATING COSTS

The roof-top units of the XHE series were created with the objective of always operating at maximum energy savings through an extremely intelligent and advanced control of power provided only when it is needed, especially during frequent conditions of operation at partial load. The use of the free-cooling device and the adoption of thermodynamic recovery on the expelled air make it possible to further reduce operating costs. Since ventilation represents one of the greatest factors of energy consumption, special attention has been given to the efficiency of the ventilation system through careful selection of components and limitations of internal pressure drops. The limitation of the emissions of carbon dioxide and respect for the environment are guiding thoughts of Clivet which, through the implementation of modern technical solutions, pursues the reduction of energy consumption.

## EASY MAINTENANCE

The entire series is designed with highly reliable industrial components that are easily accessible and available if maintenance is required. It is also equipped with self-diagnosis and safety devices that ensure its proper operation while at the same time protecting users.

VERSATILE POSITIONING: ON FLAT ROOF, ON PLATFORM ON GROUND

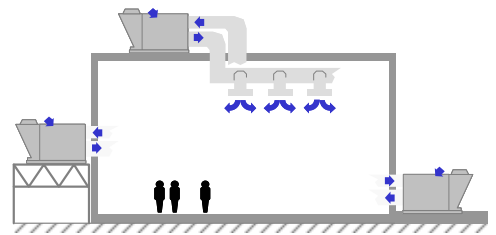

APPLICATION EXAMPLES

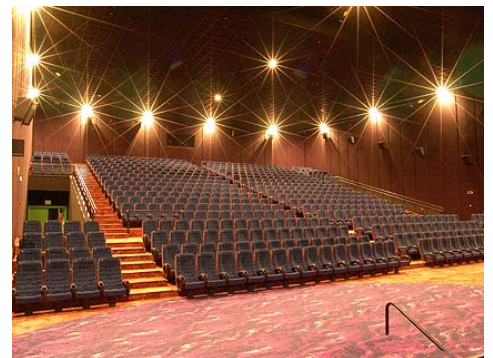

## STANDARD UNIT SPECIFICATIONS

### OPERATION PRINCIPLES UNIT

The units allow automatic control and management of supply, return, expulsion and recirculation based on client needs. The refrigeration/heat pump circuit is composed of two compressors of different sizes mounted on a single circuit, which allow adaptation to the load and increased efficiency at partial loads. The unit is capable of recovering the energy contained in the expelled air through active energy recovery. The changeover from cooling to heating in heat pump mode occurs automatically based on the temperature setpoints. The free-cooling (free-heating) function allows variable flow rates of outside air into the room while leaving the compressors off. This function is active when outdoor conditions allow it. Basic filtering is provided by G4 efficiency filters which are installed standard. The unit is standard equipped with radial plug fans coupled to brushless DC motors to provide efficient ventilation in any installation.

The variable speed radial fans in conjunction with the flow rate control device (provided standard) keep the flow rate constant even as the filters get progressively dirtier. The radial fans keep the flow rate constant even as the filters get progressively dirtier. The flow rate of recirculation air can be set to up to 80% of the supply flow rate using a motorized modulating shutter.

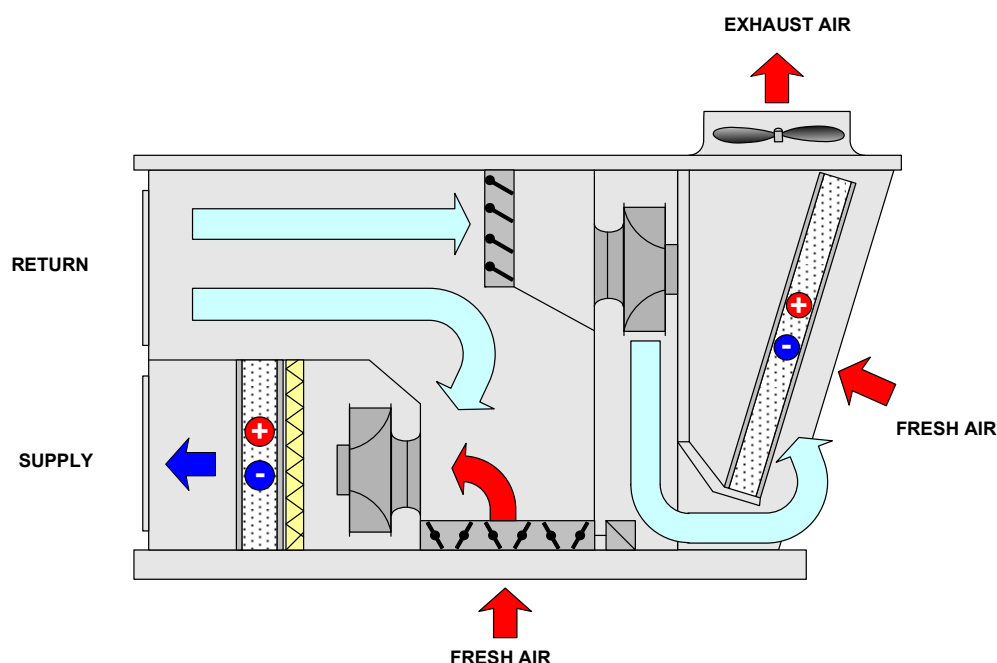

### ACTIVE ENERGY RECOVERY OF EXPELLED AIR

The energy contained in the expelled air is recovered by forcing the air flow to pass through the external packaged finned heat exchanger. This makes it possible to reduce the electrical energy absorbed by the compressors, to increase the overall efficiency of the unit and to extend its operating limits. This thermodynamic recovery system does not increase electrical energy consumption for ventilation, as instead happens for recovery with crossed or rotating flows. Greater use of electricity, caused by the enormous pressure drops on the air side in recovery systems with crossed or rotating flows, often nullifies the amount of energy recovered and even exceeds it in some cases.



E108C001CB01

**PLUG FANS EC**

The units are equipped in supply and in expulsion with radial plug fans with reversed blades directly coupled to high-performance brushless DC motors. The plug fans differ from traditional centrifugal fans in that there are no belts or pulleys. This results in increased efficiency and makes it possible to dynamically vary the speed. You can change the number of fan revs directly from the keypad to adapt the static pressure to the pressure drop of the system.



**CONSTANT VALUE FLOW RATE ADJUSTER**

This device adjusts the speed of the fans to keep a constant flow rate, adapting to system losses and compensation for the filters as they get dirty. It is composed of a pressure sensor located in the supply section which measures the pressure, and a differential pressure switch that transforms the value into an electrical signal, based on the parameters detected the machine intervenes, adjusting the speed of the motors to re-establish the set flow rate value.

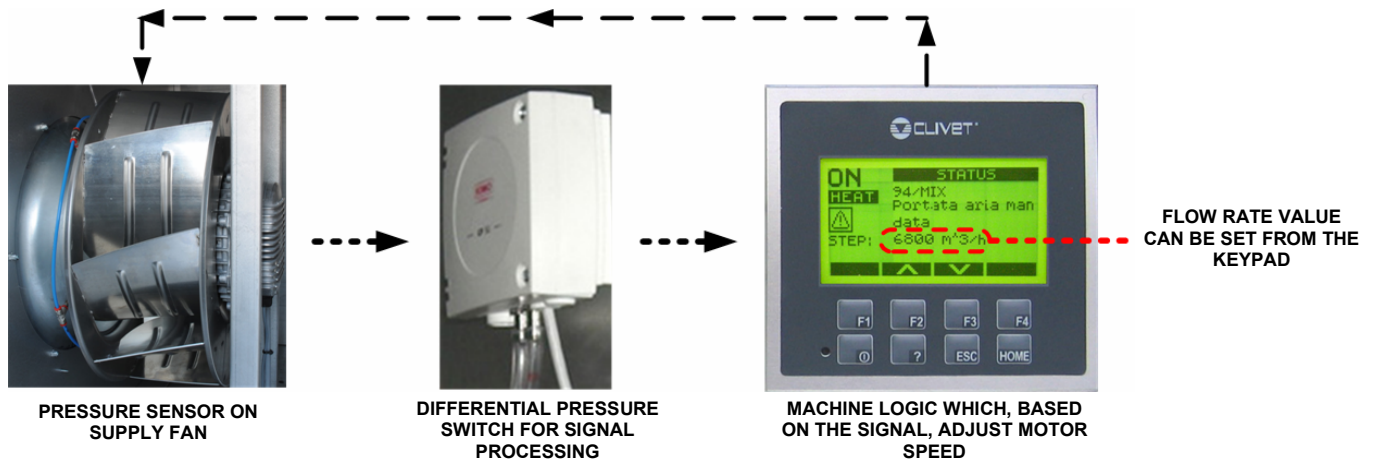

**DEVICE FOR AMBIENT PRESSURE ADJUSTMENT**

By means of the pressure sensor, located in the return section, you can compare state of the ambient pressure with the exterior and establish a parameter with ambient high pressure, negative pressure, or neutral conditions. The machine logic interprets the signal from the pressure sensor and acts on the fresh air shutter to maintain the desired ambient pressure.

The corrective action of the pressure is more marked as the difference from the established setpoint increases. The device is installed and wired on board the machine.

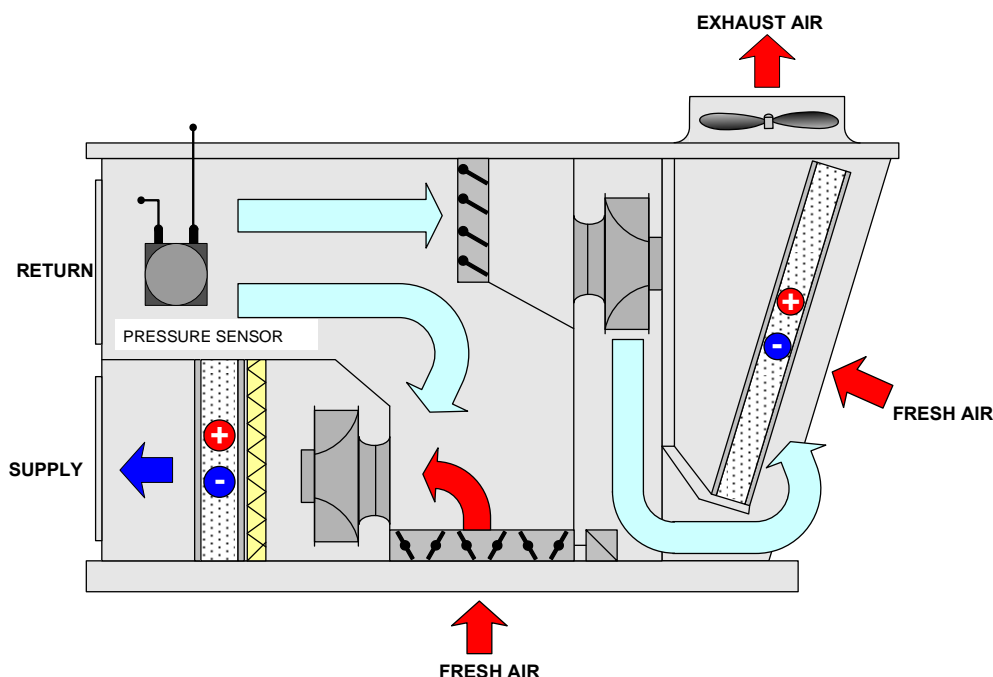

BT08C001CE-01

### ELECTRONIC EXPANSION VALVE

The electronic expansion valve is an essential component of the refrigerant circuit. It offers a number of advantages as compared to the traditional thermostatic valve. These include:

- reduction of overheating temperature (greater efficiency of refrigerant circuit)
- improved compressor working conditions (COP optimized)
- reduction of output temperature of the compressor
- reduction of pressure at condenser (less energy absorbed by compressors)
- adaptation to all load conditions and transitories without causing swinging at partial loads

All this aids in increasing the efficiency of the load for any thermal load condition and to extend the life cycle.

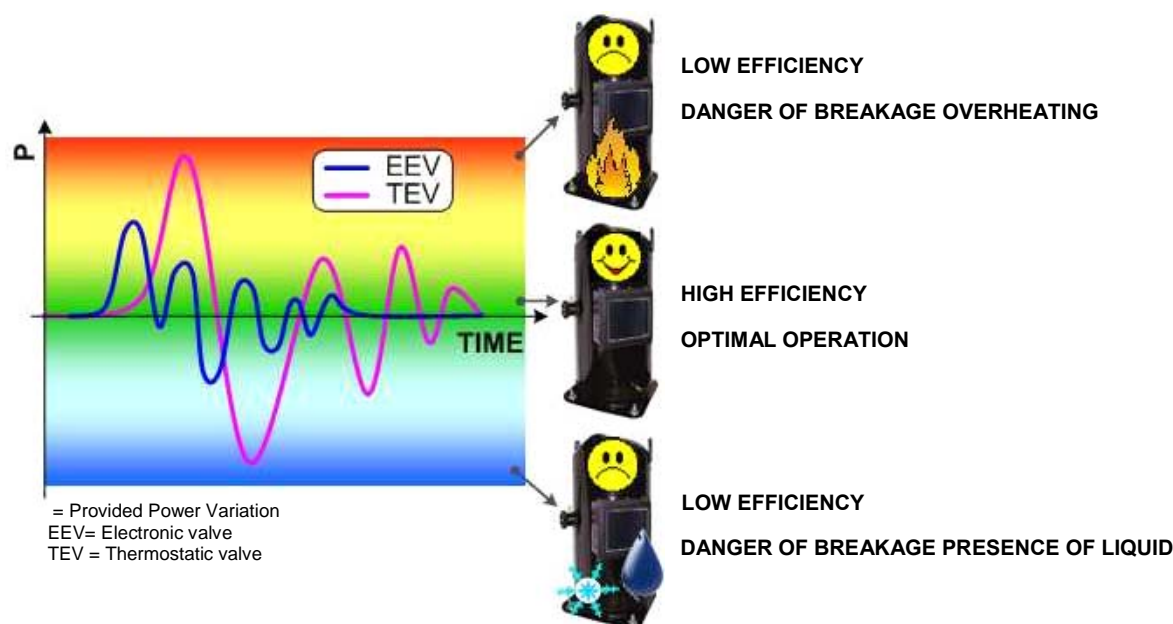

### AIR FILTERING

Standard units are standard equipped with a suitable filtering section composed of pleated filters, class G4, with an ample surface. They are easily accessible for periodic maintenance.



### UPDATED ELECTRONIC CONTROL

The operation of the unit is fully automatic thanks to the Clivet Talk electronic adjustment system. This is a modular device, of automatic origins, with high speed and reliability and control logic specifically designed for this type of product. The user interface is easy to use. This allows better use of available resources, extending the life cycle of the components and thus reducing maintenance costs. With the micro-processor keypad, it is possible to perform daily/weekly programming of the set-point, as well as start-up or shutdown of the machine. The unit can also be connected to supervision systems using clean contacts or by serial with the standards of communication most commonly available on the market.



BT08C001CB01

**NEW GENERATION OF AXIAL FANS FOR THE EXTERNAL SECTION**

The need for continuous improvement in machine performance has led to collaboration with specialized European laboratories for the development of more efficient axial fans. The result of this research has made it possible to develop an innovative winglet-type profile at the end of the blade. The adoption of the new profiles has made it possible to obtain substantial results in noise limitation, with an average reduction of 6 dB(A), and energy savings, with a reduction in consumption of 10%.

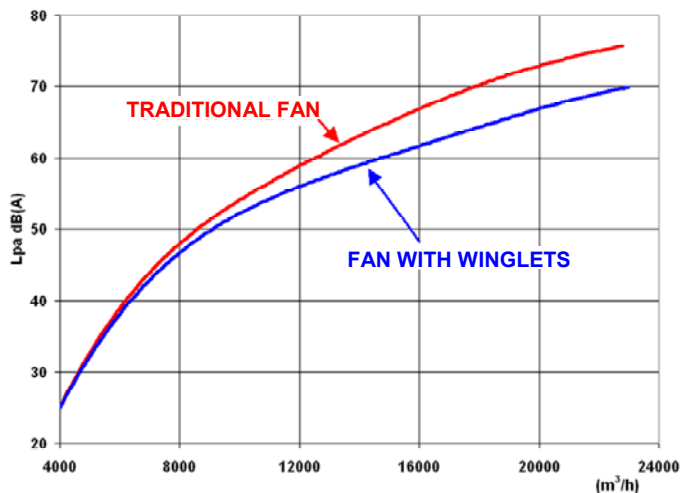
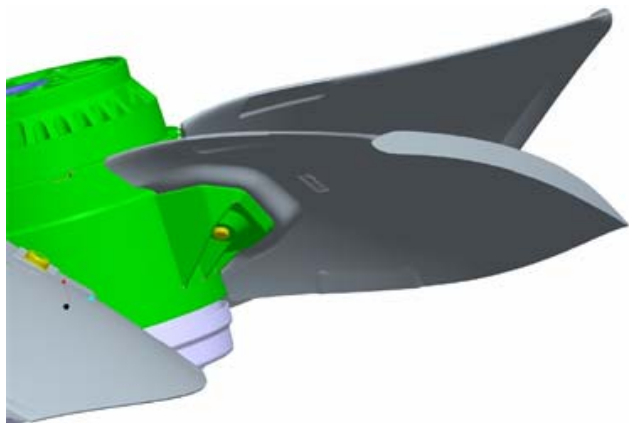

**DEVICE TO REDUCE CONSUMPTION OF FANS OF THE EXTERNAL SECTION**

The device makes it possible to control the external axial fans, adjusting their speed of rotation based on the condensation pressure. When fresh air temperature is low, a minimum air flow rate is required to hold down the condensation pressure. Therefore, at low fresh air temperatures, fan rotation speed is reduced, resulting in reduced energy consumption (low temperature device).

In certain applications where the external temperature is low and it is not possible to draw in fresh air to cool the served room (free cooling), the phase cut device allow the unit to operate correctly.

In heat pump mode, this device reduces the speed of rotation of the fans when external air temperatures are high (high temperature device).

**OUTSIDE TEMPERATURE PROBE**

The measurement of the temperature of outside air is an essential parameter of heat adjustment. It takes place via a probe located in a special compartment that connects the external environment and the return duct (always in negative pressure). Clivet has chosen this solution to ensure correct measurement of temperature since the probe is constantly in contact with a minimum flow of air. On request, the temperature probe can be integrated with the optional humidity probe).

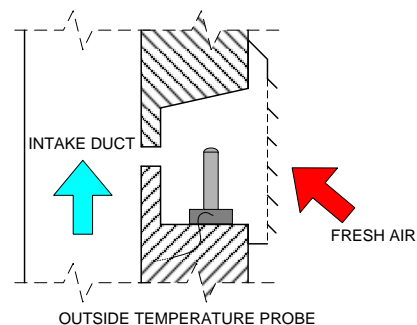

**THERMAL FREE COOLING**

As soon as external conditions allow it, the unit is capable of automatically activating free-cooling mode, which, by keeping the compressors off and drawing in suitably filtered fresh air, cools the served room. The fresh air flow can be varied based on actual needs. This operating mode is especially useful in spring and autumn or with high ambient loads. It allows substantial reduction of the unit's energy consumption and wear of the compressors.



BT08C001CE-01

### VERY HIGH EFFICIENCY AT PARTIAL LOAD

In air conditioning projects, the choice of the unit is made based on the maximum load of the room to be served. In practice, over the course of the year these operating conditions are limited to short periods of time, whereas operation at partial loads is the actual normal operating condition. The need to adapt the power provided to the load requested becomes essential in limiting energy consumption. This is why we have decided to couple two scroll compressors of different power on a single refrigeration circuit, thus obtaining very high efficiency. The electronic control that the machine is equipped with divides compressor operation into three steps of power (1/3, 2/3, 3/3). This limits the oscillation of the air temperature, and provides perfect adaptation to partial load, offering substantial energy savings.

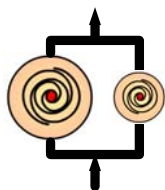
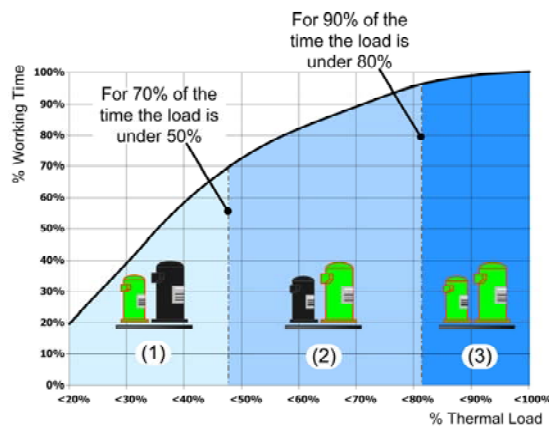
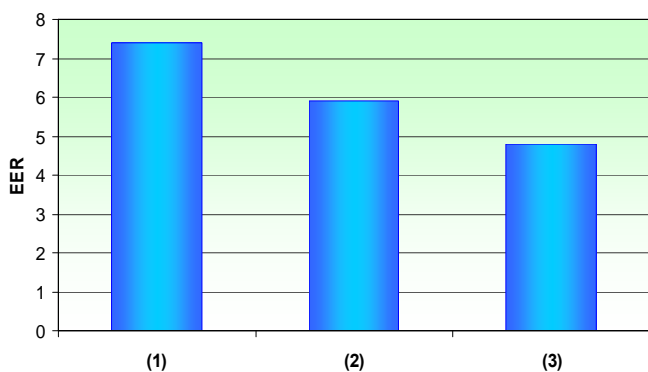

### SELF-ADAPTABILITY

Thanks to the automatic adjustment of the operating parameters based on the system load conditions, the unit is capable of optimizing its own efficiency, reducing the resulting consumption and extending the life-cycle of the components. The temperature range to be maintained in the room can be set by the user (manual set-point) or managed by the machine logic (automatic set-point). When AUTOMATIC mode is set, the working set-points are calculated automatically and dynamically by the thermal control device based on the outside temperature and other parameters set during commissioning of the machine, thus avoiding thermal shock between the treated room and the exterior.

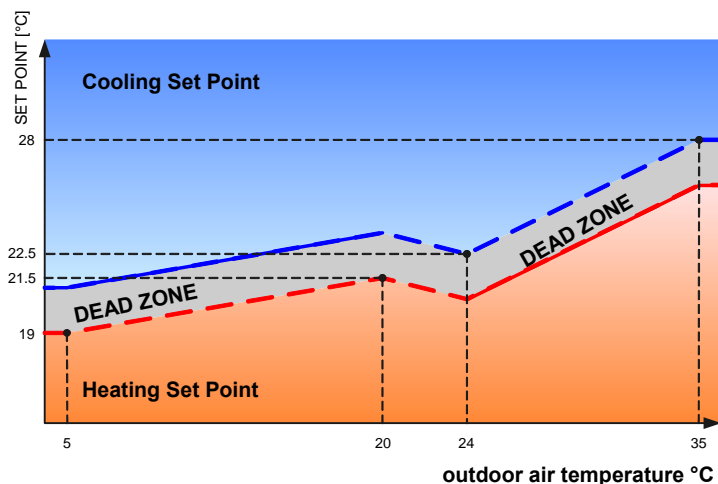

THE GRAPH SHOWS THE TREND OF THE CURVES OF THE HOT SET POINT (BOTTOM LINE) AND OF THE COLD SET POINT (UPPER LINE) BASED ON THE OUTSIDE TEMPERATURE. THE HIGHLIGHTED TEMPERATURE VALUES ARE THOSE SET AS DEFAULT, BUT THEY MAY BE CHANGED ACCORDING TO CLIENT NEEDS.

BI08C001CB01

### ICE PROTECTION SYSTEM

ICE PROTECTION SYSTEM is a special measure for the refrigeration circuit that reduces the risk of the formation of ice at the base of the external coil. A liquid under-cooling circuit maintains the temperature of the lower part of the coil, preventing the formation of a block of ice and avoiding risk of breakage due to freezing.

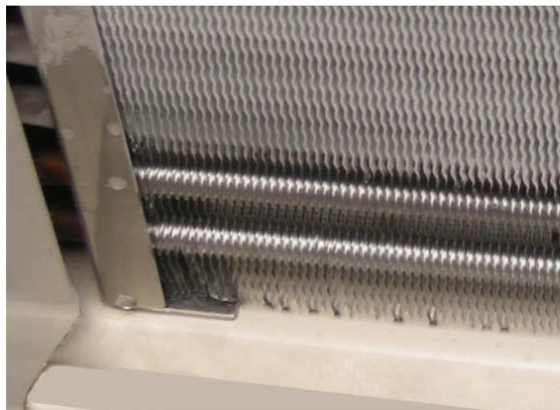

### SMART MANAGEMENT OF DEFROSTS

During operation in heat-pump mode, the defrost cycles are managed with an advanced, predictive logic that reduces both frequency and duration. The innovative control system makes it possible to activate defrost cycles and to adjust their duration based on actual needs, by measuring not only the outside temperature but also the gradient of evaporation pressure. As a result, overall performance of the machine is improved and there is a reduction in the negative effect that defrost cycles have on supply air temperatures.



### DEMAND LIMIT

The Demand Limit function is a logic that controls the machine's resources dedicated to limiting the input power from the electrical mains (for example when there are special agreements between the user and the operator of the electrical mains) or to selecting the thermal resources to be used based on special needs of the client. The Demand Limit device can control and manage the available steps of thermal power by means of the receipt of an external analogue signal, 0-10V/4-20mA. The control logic does not act on the ventilation which is therefore always ensured. The greater the input signal to the Demand Limit, the less the thermal power available for the system. In the extreme condition of pilot signal at 100%, the system can also shut off the last power step.

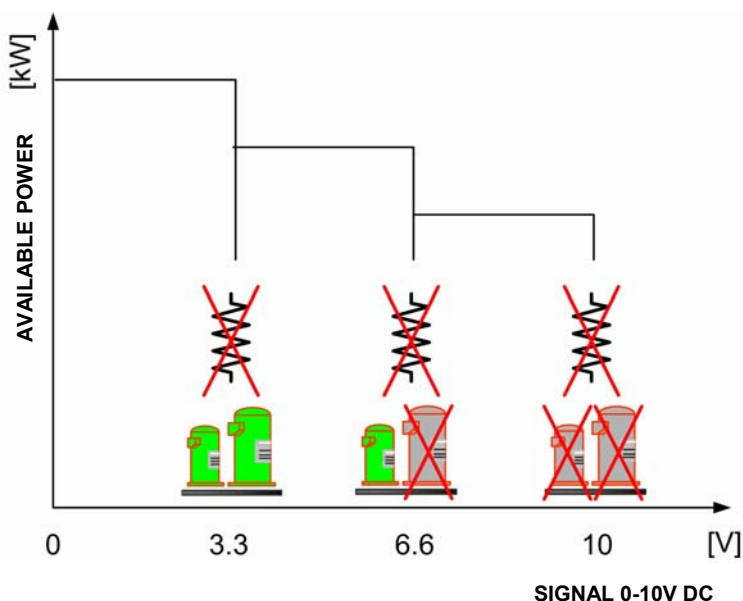

AS THE DEMAND LIMIT SIGNAL INCREASES, THE POWER STEPS ARE GRADUALLY DISABLED. WHEN THE SIGNAL IS AT 100%, ALL AVAILABLE RESOURCES ARE DISABLED.

 AUXILIARY ELECTRIC HEATING ELEMENTS

## STANDARD UNIT SPECIFICATIONS

### COMPRESSOR

Scroll compressor complete with: overload thermal protection, high refrigerant discharge temperature, rubber antivibration mounts, oil charge.

A oil heater is automatically switched on at the compressor shut-down to prevent oil dilution by the refrigerant.

The compressors are connected in tandem on a single refrigerator circuit. They have bi-phase equalization of the oil and are equipped with cut-off bi-blocks

### STRUCTURE

The basement is assembled with a painted galvanized steel frame. The internal structure is made of "ALUZINK" bent galvanized steel. The alloy that protects the Aluzink allow an excellent corrosion proofing thanks to the galvanic protection typical of the combination aluminium-zinc.

### PANELLING

Panels of the compressor panel in steel sheet metal, painted using polyester powders, colour RAL 9001 and covered on the inside with ashlar sound-absorbent material.

Sandwich panels in the air treatment section with dual walls in steel sheet metal with polyurethane insulation (40 kg/m<sup>3</sup>), thickness of outer sheet metal 6/10 mm galvanized and painted using polyester powders colour RAL 9001, polyurethane thickness with thermal conductivity coefficient 0.022W/mK, thickness of internal sheet metal 5/10 mm hot galvanized. The panel is also provided with a PVC profile for thermal insulation and a EPDM rubber gasket that ensures the hermetic seal.

All panelling can easily be removed to allow complete accessibility to internal components.

### INTERNAL EXCHANGER

Direct expansion finned exchanger, made from copper pipes in staggered rows and mechanically expanded to the fin collars. The fins are made from aluminium with a corrugated surface and adequately distanced to ensure the maximum heat exchange efficiency.

### EXTERNAL EXCHANGER

Direct expansion finned exchanger, made from copper pipes in staggered rows and mechanically expanded to the fin collars. The fins are made from aluminium with a corrugated surface and adequately distanced to ensure the maximum heat exchange efficiency.

The coils are complete with integral subcooling circuit which assures the correct refrigerant feeding of the expansion valve. This circuit prevents the formation of frost on the exchanger during winter operation. Available in different options as per optional list.

### FAN

Internal section

Supply fan

Plug fans without scroll with reverse blades driven by electronically-controlled "brushless" dc motors with direct coupling. No transmission sizing is needed. The fan is equipped with a self-adjustment device to keep the flow rate constant.

Exhaust fan

Plug fans without scroll with reverse blades driven by electronically-controlled "brushless" dc motors with direct coupling. No transmission sizing is needed.

External section

Helical fans with shaped aluminium blades, directly coupled to the three-phase electric motor, with built-in thermal overload protection, minimum IP 54 construction. Mounted in aerodynamic housings to increase efficiency and minimize noise levels, and fitted with safety grills.

### REFRIGERANT CIRCUIT

The circuit is complete with:

- refrigerant charge
- sight glass with moisture indicator
- high pressure switch
- low pressure switch
- filter dryer
- electronic expansion valve
- non-return valve
- 4-way reverse cycle valve
- liquid receiver
- liquid separator
- high pressure safety valve
- low pressure safety valve

### FILTRATION

Fresh air intake side

Pleated filter for greater filtering surface, made up of galvanized plate frame with galvanized and electric-welded protective mesh, and regenerable filtering media made from polyester fibre sized with synthetic resins. G4 efficiency according to CEN-EN 779 standard (Eurovent class EU4/5 - average efficiency 90.1% ASHRAE 52-76 Atm). Self-extinguishing (resistance to fire class 1 - DIN 53438).

Ambient air suction side

Pleated filter for greater filtering surface, made up of galvanized plate frame with galvanized and electric-welded protective mesh, and regenerable filtering media made from polyester fibre sized with synthetic resins. G4 efficiency according to CEN-EN 779 standard (Eurovent class EU4/5 - average efficiency 90.1% ASHRAE 52-76 Atm). Self-extinguishing (resistance to fire class 1 - DIN 53438).

### TRAY

Condensate collecting tray in aluminum alloy 1050 H24 with anti-condensate insulation, welded and equipped with threaded discharge coupling

### ELECTRICAL PANEL

The electrical panel is positioned inside the units, with access through a swing door that is opened by a special key.

The Power Section includes:

- main door lock isolator switch
  - compressor circuit breaker
  - remote switches for power supply to compressors and fans
  - fan motor thermal protections of internal section and external section
  - circuit breaker to protect auxiliary circuit
- Microprocessor control section:
- treated air temperature control
  - daily, weekly programmer of temperature setpoint and unit on/off
  - compressor overload protection and timer
  - self-diagnosis system with immediate display of the error code
  - demand limit
  - clean contacts for remote ON-OFF, cumulative alarm, fan status, compressor status, summer/winter mode
  - control keypad, including:
    - display to indicate operating status and mode
    - display of the set values and the error codes
    - menu button to display the parameter index
    - ALARM button to access the alarm management functions
    - status button to display the status list
    - unit operation or ventilation only selection button
    - On/Off and manual reset button for overload device activation
    - UP and DOWN buttons to increase and decrease the values

### ACCESSORIES

- copper / copper evaporator coils
  - copper / copper condenser coils
  - water heating coil
  - three-way valve
  - hot gas re-heating coil
  - Copper / copper hot gas re-heating coil
  - electrode boiler steam humidifier
  - water to waste evaporating wet-deck humidifier
  - auxiliary electric heaters.
  - Air quality sensor for CO<sub>2</sub> p.p.m. control
  - Air quality sensor for CO<sub>2</sub> and VOC p.p.m. control
  - bag filters section F7 class
  - High efficiency electrostatic filters additional section
  - Intake silencers
  - serial port RS485 with MODBUS protocol
  - serial port RS485 with LONWORK protocol
  - phase monitor
  - power factor correction capacitors (cosφ > 0.9)
  - free-cooling with independent comparison of temperature and absolute humidity
  - Variable fan speed control for operation at low ambient temperature
- ECOBreeze
- differential pressure switch for dirty air filters
  - high and low pressure gauges
  - smoke detector
  - Remote control with remote microprocessor control (separately supplied accessories)
  - Rubber antivibration mounts (separately supplied accessories)

### TEST

Unit manufactured according to the ISO 9001 quality standards and subject to functional testing at the end of the production line

E108C001CB01

**ENERGY EFFICIENCY: OPERATION WITH 80% EXTERNAL AIR**

**GENERAL TECHNICAL SPECIFICATIONS**

Size			102	122	162	182	222	262	302	362	402
<b>COOLING</b>											
Cooling capacity	1	kW	41.1	47.8	56.2	66.9	79.4	91.4	107.8	121.5	137.5
Sensible capacity	1	kW	23.8	27.9	33.9	40.7	47.7	54.7	65	72.3	79.3
Compressor power input	1	kW	9.1	11.5	13.1	15.1	18.6	21.5	24	26.7	31.3
EER	1		4.52	4.15	4.3	4.44	4.27	4.25	4.49	4.54	4.4
<b>HEATING</b>											
Heat output	2	kW	40	46.6	54.5	64.9	75.8	90.5	102.6	121.1	136.2
Compressor power input	2	kW	7.8	9	10.3	12.2	13.9	16.6	17.9	22.1	25.5
COP	2		5.13	5.2	5.31	5.32	5.46	5.45	5.72	5.48	5.35
<b>COMPRESSOR</b>											
Type of compressors	3		Scroll	Scroll	Scroll	Scroll	Scroll	Scroll	Scroll	Scroll	Scroll
No. of Compressors		Nr	2	2	2	2	2	2	2	2	2
Std Capacity control steps		Nr	3	2	3	3	3	3	2	3	3
Refrigerant charge (C1)		kg	17	18	18	24	25	26	33	36	37
Refrigerant circuits		Nr	1	1	1	1	1	1	1	1	1
<b>AIR HANDLING SECTION FANS (OUTLET)</b>											
Type of fans	4		RAD	RAD	RAD	RAD	RAD	RAD	RAD	RAD	RAD
Number of fans		Nr	1	1	1	1	1	1	2	2	2
Fan diameter		mm	500	500	500	560	560	630	500	500	500
Type of motor			CC	CC	CC	CC	CC	CC	CC	CC	CC
Air flow		l/s	1200	1500	1890	2170	2680	3250	3900	4200	4580
Installed unit power		kW	2.7	2.7	2.7	3.1	3.1	3.2	2.7	2.7	2.7
Max outside static pressure	5	Pa	720	690	600	620	480	400	590	540	440
<b>FANS (EXPULSION)</b>											
Type of fans	4		RAD	RAD	RAD	RAD	RAD	RAD	RAD	RAD	RAD
Number of fans		Nr	1	1	1	1	1	1	1	1	1
Type of motor			CC	CC	CC	CC	CC	CC	CC	CC	CC
Air flow		l/s	960	1200	1510	1740	2140	2600	3120	3360	3660
Installed unit power		kW	1	1	1	2.7	2.7	3.1	3.2	3.2	3.2
<b>EXTERNAL SECTION FANS</b>											
Type of fans	6		AX	AX	AX	AX	AX	AX	AX	AX	AX
Number of fans		Nr	1	1	1	2	2	2	2	2	2
Fan diameter		mm	800	800	800	710	710	710	800	800	800
Fan RPM		rpm	660	660	880	900	900	900	880	880	880
Standard air flow		l/s	5700	5700	5700	6670	6670	6670	11400	11400	11400
Installed unit power		kW	1.2	1.2	1.9	1.1	1.1	1.1	1.9	1.9	1.9
<b>POWER SUPPLY</b>											
Standard power supply		V	400/3/50	400/3/50	400/3/50	400/3/50	400/3/50	400/3/50	400/3/50	400/3/50	400/3/50

- (1) Ambient temperature 27°C/19.5 WB  
outdoor air temperature 35°C
- (2) Ambient air 20°C D.B.; fresh air 7°C D.B./6.1 W.B.  
operation with 80% external air
- (3) SCROLL = scroll compressor
- (4) RAD = radial ventilation
- (5) Net outside static pressure to win the outlet and intake onboard pressure drops
- (6) AX = axial-flow fan

**SOUND LEVELS**

**Air flow: standard**

Size	Sound Power Level (dB)								Sound pressure level dB(A)	Sound power level dB(A)
	Octave band (Hz)									
	63	125	250	500	1000	2000	4000	8000		
102	86	80	82	76	78	70	69	61	63	81
122	86	80	83	78	78	73	67	57	63	82
162	86	79	83	81	80	72	67	59	65	83
182	88	89	89	82	79	76	69	67	67	86
222	88	89	90	83	80	76	71	63	67	86
262	88	89	90	82	80	78	72	67	68	87
302	90	84	89	82	85	81	74	69	69	88
362	90	83	89	85	85	82	76	68	70	89
402	90	84	90	86	85	82	76	64	70	90

The sound levels are referred to units working at full load in nominal conditions. The sound pressure level is referred at a distance of 1 m. from the ducted unit surface working in free field conditions. External static pressure 50 Pa. (standard UNI EN ISO 3744)  
Please note that when the unit is installed in conditions other than nominal test conditions (e.g. near walls or obstacles in general), the sound levels may undergo substantial variations.

VOLTAGE: 400/3/50

**ELECTRICAL DATA**

Size		102	122	162	182	222	262	302	362	402
<b>F.L.A. - FULL LOAD CURRENT AT MAX ADMISSIBLE CONDITIONS</b>										
F.L.A. - Compressor 1	A	14.3	14.3	16.4	22.6	30.6	30.6	30.6	36.5	44.9
F.L.A. - Compressor 2	A	9.8	14.3	15.2	15.2	15.2	22.6	30.6	30.6	30.6
F.L.A. - Single External Fan	A	2.3	2.3	4.1	2.5	4.1	4.1	4.1	4.1	4.1
F.L.A. - Single supply fan	A	4.3	4.3	4.3	4.9	4.9	4.9	4.3	4.3	4.3
F.L.A. - Single exhaust air fan	A	2.2	2.2	2.2	4.3	4.3	4.9	4.9	4.9	4.9
F.L.A. - Total	A	33.4	37.9	42.7	52.5	63.7	71.7	83.4	89.3	97.7
<b>L.R.A. LOCKED ROTOR AMPERES</b>										
L.R.A. - Compressor 1	A	101	101	111	118	173	173	173	225	272
L.R.A. - Compressor 2	A	64	101	95	95	95	118	173	173	173
<b>F.L.I. FULL LOAD POWER INPUT AT MAX ADMISSIBLE CONDITION</b>										
F.L.I. - Compressor 1	kW	8.3	8.3	10.1	13.2	17	17	17	22.6	27.3
F.L.I. - Compressor 2	kW	5.9	8.3	8.9	8.9	8.9	13.2	17	17	17
F.L.I. - Single External Fan	kW	1.2	1.2	1.9	1.1	1.9	1.9	1.9	1.9	1.9
F.L.I. - Single supply fan	kW	2.7	2.7	2.7	3.1	3.1	3.2	2.7	2.7	2.7
F.L.I. - Single exhaust air fan	kW	1	1	1	2.7	2.7	3.1	3.2	3.2	3.2
F.L.I. - Total	kW	19.4	21.8	24.9	30.3	35.8	40.6	46.7	52.3	57
<b>M.I.C. MAXIMUM INRUSH CURRENT</b>										
M.I.C. - Value	A	120.1	124.6	137.3	147.9	206.1	214.1	225.8	277.8	324.8

Data referred to standard units.  
power supply: 400/3/50 Hz +/-6%  
voltage unbalance: max 2 %  
Values not including accessories

**ELECTRICAL INPUT OF OPTIONAL COMPONENTS**

To obtain the electrical input of the unit including accessories, add the standard data in Electrical Data table to those for the selected accessories.

SIZE		102	122	162	182	222	262	302	362	402
<b>F.L.A. FULL LOAD CURRENT</b>										
F.L.A. EH10 - 6 kW electric heaters	A	8,7	8,7	8,7	-	-	-	-	-	-
F.L.A. EH12 - 9 kW electric heaters	A	13	13	13	-	-	-	-	-	-
F.L.A. EH14 - 12 kW electric heaters	A	17,3	17,3	17,3	17,3	17,3	17,3	-	-	-
F.L.A. EH17 - 18 kW electric heaters	A	-	-	-	26	26	26	26	26	26
F.L.A. EH20 - 24 kW electric heaters	A	-	-	-	34,6	34,6	34,6	34,6	34,6	34,6
F.L.A. EH24 - 36 kW electric heaters	A	-	-	-	-	-	-	52	52	52
F.L.A. HSE3 - Electrode boiler steam humidifier from 3 kg/h	A	3,2	3,2	3,2	-	-	-	-	-	-
F.L.A. HSE5 - Electrode boiler steam humidifier from 5 kg/h	A	8,7	8,7	8,7	8,7	8,7	8,7	-	-	-
F.L.A. HSE8 - Electrode boiler steam humidifier from 8 kg/h	A	8,7	8,7	8,7	8,7	8,7	8,7	8,7	8,7	8,7
F.L.A. HSE9 - Electrode boiler steam humidifier from 15 kg/h	A	-	-	-	16,2	16,2	16,2	16,2	16,2	16,2
F.L.A. FES - High efficiency H10 electrostatic air filter	A	1,1	1,1	1,1	1,5	1,5	1,5	2,2	2,2	2,2
<b>F.L.I. FULL LOAD POWER INPUT</b>										
F.L.I. EH10 - 6 kW electric heaters	kW	6	6	6	-	-	-	-	-	-
F.L.I. EH12 - 9 kW electric heaters	kW	9	9	9	-	-	-	-	-	-
F.L.I. EH14 - 12 kW electric heaters	kW	12	12	12	12	12	12	-	-	-
F.L.I. EH17 - 18 kW electric heaters	kW	-	-	-	18	18	18	18	18	18
F.L.I. EH20 - 24 kW electric heaters	kW	-	-	-	24	24	24	24	24	24
F.L.I. EH24 - 36 kW electric heaters	kW	-	-	-	-	-	-	36	36	36
F.L.I. HSE3 - Electrode boiler steam humidifier from 3 kg/h	kW	2,3	2,3	2,3	-	-	-	-	-	-
F.L.I. HSE5 - Electrode boiler steam humidifier from 5 kg/h	kW	6,0	6,0	6,0	6,0	6,0	6,0	-	-	-
F.L.I. HSE8 - Electrode boiler steam humidifier from 8 kg/h	kW	6,0	6,0	6,0	6,0	6,0	6,0	6,0	6,0	6,0
F.L.I. HSE9 - Electrode boiler steam humidifier from 15 kg/h	kW	-	-	-	11,3	11,3	11,3	11,3	11,3	11,3
F.L.I. FES - High efficiency H10 electrostatic air filter	kW	0,25	0,25	0,25	0,33	0,33	0,33	0,5	0,5	0,5

E108C001CEB01

**OPERATING LIMITS (COOLING)**

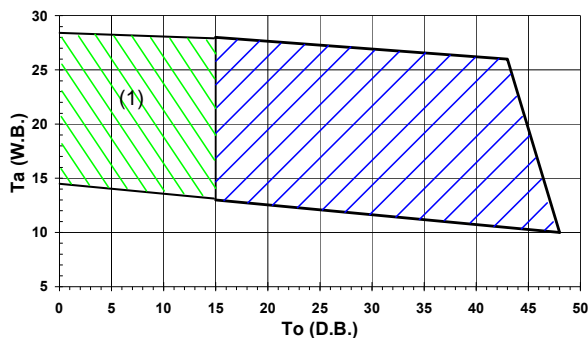

THE LIMITS ARE INDICATIVE AND HAVE BEEN CALCULATED CONSIDERING:  
 - VALUES GENERAL AND NOT SPECIFICATIONS,  
 - STANDARD AIR FLOW-RATE,  
 - NON-CRITICAL POSITIONING AND CORRECT USE OF THE UNIT,  
 - OPERATION AT FULL LOAD  
 WITH UNIT OPERATING IN INTAKE OF OUTSIDE AIR CALCULATE THE TEMPERATURES OF MIXES WHICH ARE GENERATED FROM THE EXCHANGERS' INLET TO KNOW THE LIMITS.  
 TA = INTERNAL EXCHANGER INLET AIR TEMPERATURE W.B. (°C)  
 WB = WET BULB  
 TO = TEMPERATURE OF AIR ENTERING THE EXTERNAL EXCHANGER D.B.(°C)  
 DB = DRY BULB  
 THE LIMITS ARE INDICATIVE AND HAVE BEEN CALCULATED CONSIDERING:  
 - VALUES GENERAL AND NOT SPECIFICATIONS,  
 - STANDARD AIR FLOW-RATE,  
 - NON-CRITICAL POSITIONING AND CORRECT USE OF THE UNIT,  
 - OPERATION AT FULL LOAD  
 (1) -THE DASHED AREA OF THE GRAPH IN COOLING OPERATION REFERS TO THE FIELD OF OPERATION FOR UNITS IN FREE COOLING

**OPERATING LIMITS (HEATING)**

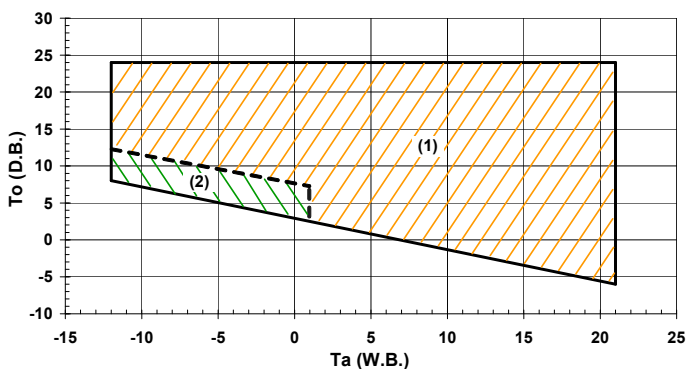

THE LIMITS ARE INDICATIVE AND HAVE BEEN CALCULATED CONSIDERING:  
 - VALUES GENERAL AND NOT SPECIFICATIONS,  
 - STANDARD AIR FLOW-RATE,  
 - NON-CRITICAL POSITIONING AND CORRECT USE OF THE UNIT,  
 - OPERATION AT FULL LOAD  
 WITH UNIT OPERATING IN INTAKE OF OUTSIDE AIR CALCULATE THE TEMPERATURES OF MIXES WHICH ARE GENERATED FROM THE EXCHANGERS' INLET TO KNOW THE LIMITS.  
 TO = TEMPERATURE OF AIR ENTERING THE INTERNAL EXCHANGER D.B.(°C)  
 DB = DRY BULB  
 TA = EXTERNAL EXCHANGER INLET AIR TEMPERATURE W.B. (°C)  
 WB = WET BULB  
 (1) THE DASHED AREA REFERS TO THE FIELD OF UNITS OPERATION STANDARD  
 (2) INSIDE THE DOTTED AREA, THE UNIT CAN OPERATE ONLY FOR A LIMITED PERIOD OF TIME (MAX 1 HOUR)  
 IN EXTENDED OPERATING MODE, IN HEAT PUMP OPERATION WITH AN OUTSIDE AIR TEMPERATURE OF LESS THAN 6°C, THE UNIT PERFORMS DEFROSTS BY REVERSING THE CYCLE, SO AS TO ELIMINATE THE ICE THAT FORMS ON THE SURFACES OF THE OUTSIDE EXCHANGER; IN ADDITION, IN THE EVENT OF NEGATIVE TEMPERATURES, THE WATER RESULTING FROM THE DEFROSTS MUST BE DRAINED SO AS TO AVOID THE ACCUMULATION OF ICE NEAR THE BASE OF THE UNIT. MAKE SURE THAT THIS DOES NOT CONSTITUTE A DANGER FOR PEOPLE OR THINGS.

**PRESSURE DROPS OF OPTIONAL COMPONENTS**

The value of static pressure available on the supply and return duct is obtained by subtracting from the available net maximum pressure (see general table of technical data) the pressure drops of any accessories.

SIZE			102	122	162	182	222	262	302	362	402
<b>PRESSURE DROP</b>											
CHW2	2 rows hot water coil	Pa	14	18	26	20	28	38	30	34	39
SI	Intake silencers	Pa	30	35	40	30	35	40	30	35	40
CPHG	Hot gas re-heating coil	Pa	10	15	20	10	15	20	10	15	20
F7	High efficiency F7 air filter	1 Pa	90	95	100	90	95	100	90	95	100
FES	High efficiency H10 electrostatic air filter	Pa	15	20	25	15	20	25	15	20	25
HWS	Water to waste evaporating wet-deck humidifier	Pa	10	15	20	10	15	20	10	15	20

The values shown are to be considered approximate for units operating power in normal use with standard air flow rate.  
 (1) Pressure drops with filters with average dirtiness

BT08COOLCE01

**ENERGY EFFICIENCY: OPERATION WITH 40% EXTERNAL AIR**

**COOLING PERFORMANCE**

Size	Ta (°C) DB/WB	OUTDOOR AIR TEMPERATURE °C																	
		25			30			32			35			40			44		
		kWf	kWe	kWs	kWf	kWe	kWs	kWf	kWe	kWs	kWf	kWe	kWs	kWf	kWe	kWs	kWf	kWe	kWs
102	22 / 16	34.4	7.01	23.7	34.8	7.94	22.9	35.1	8.32	22.6	35.6	8.91	22.1	36.7	9.93	21.4	37.9	10.8	20.8
	24 / 17	35.0	7.06	24.9	35.5	7.99	24.1	35.8	8.37	23.8	36.3	8.96	23.4	37.2	9.99	22.6	38.2	10.9	22.0
	26 / 19	36.2	7.17	24.8	36.9	8.09	24.0	37.1	8.47	23.7	37.5	9.06	23.3	38.3	10.1	22.5	39.0	11.0	21.9
	27 / 19.5	36.6	7.20	25.4	37.2	8.12	24.7	37.4	8.50	24.4	37.9	9.09	23.9	38.6	10.1	23.1	39.2	11.0	22.5
	28 / 21	37.6	7.28	24.7	38.1	8.20	23.9	38.4	8.58	23.6	38.8	9.17	23.2	39.5	10.2	22.4	40.2	11.1	21.9
	30 / 22	38.3	7.33	25.9	38.7	8.26	25.2	39.0	8.64	24.9	39.4	9.23	24.5	40.2	10.2	23.8	40.9	11.1	23.2
122	22 / 16	40.4	8.78	28.0	41.2	9.85	27.1	41.5	10.3	26.7	42.0	11.0	26.1	43.0	12.2	25.2	43.8	13.2	24.4
	24 / 17	40.8	8.88	29.5	41.6	9.96	28.5	42.0	10.4	28.1	42.5	11.1	27.5	43.5	12.3	26.6	44.4	13.4	25.8
	26 / 19	42.1	9.07	29.1	42.8	10.2	28.2	43.2	10.6	27.8	43.7	11.3	27.2	44.6	12.6	26.3	45.4	13.6	25.6
	27 / 19.5	42.5	9.12	29.8	43.2	10.2	28.9	43.5	10.7	28.5	44.0	11.4	28.0	44.9	12.6	27.1	45.6	13.6	26.4
	28 / 21	43.9	9.26	29.0	44.5	10.3	28.2	44.8	10.8	27.9	45.2	11.5	27.4	45.8	12.7	26.5	46.3	13.7	25.9
	30 / 22	45.0	9.35	31.0	45.5	10.4	30.2	45.7	10.9	29.9	46.0	11.6	29.5	46.4	12.7	28.7	46.7	13.7	28.1
162	22 / 16	47.5	10.2	33.0	48.4	11.4	32.0	48.8	11.9	31.6	49.2	12.7	31.0	49.8	14.0	30.0	50.1	15.2	29.3
	24 / 17	48.3	10.3	34.9	48.9	11.5	33.9	49.2	12.0	33.5	49.7	12.8	32.9	50.6	14.2	31.9	51.6	15.3	31.1
	26 / 19	49.9	10.4	35.1	50.1	11.7	34.1	50.4	12.2	33.7	50.9	13.0	33.1	52.2	14.4	32.1	53.6	15.5	31.3
	27 / 19.5	50.3	10.5	36.1	50.5	11.7	35.1	50.8	12.2	34.7	51.3	13.0	34.1	52.5	14.4	33.0	53.9	15.6	32.2
	28 / 21	51.6	10.6	34.5	51.9	11.9	33.5	52.2	12.4	33.1	52.6	13.2	32.5	53.5	14.6	31.5	54.4	15.7	30.6
	30 / 22	52.5	10.8	35.4	53.0	12.0	34.3	53.3	12.5	33.9	53.6	13.3	33.3	54.1	14.6	32.3	54.4	15.8	31.5
182	22 / 16	56.9	11.9	39.4	58.0	13.3	38.1	58.4	13.8	37.6	59.0	14.7	36.8	59.8	16.2	35.6	60.3	17.4	34.5
	24 / 17	57.8	12.0	41.7	59.1	13.3	40.4	59.5	13.9	39.9	60.0	14.8	39.1	60.5	16.3	37.8	60.6	17.6	36.8
	26 / 19	59.8	12.1	42.1	61.0	13.5	40.8	61.4	14.0	40.3	61.8	14.9	39.5	62.0	16.5	38.2	61.9	17.7	37.2
	27 / 19.5	60.3	12.2	43.2	61.4	13.5	41.9	61.8	14.1	41.4	62.2	15.0	40.6	62.4	16.5	39.3	62.4	17.8	38.3
	28 / 21	62.2	12.3	40.9	62.7	13.7	39.6	62.9	14.3	39.1	63.2	15.1	38.3	63.7	16.6	37.0	64.1	17.8	35.9
	30 / 22	63.5	12.4	41.2	63.4	13.8	39.8	63.5	14.4	39.3	63.8	15.3	38.5	64.5	16.7	37.1	65.4	17.8	36.0
222	22 / 16	67.0	14.7	47.0	68.3	16.3	45.6	68.9	17.0	45.0	69.7	18.1	44.2	71.1	20.1	42.8	72.2	21.7	41.7
	24 / 17	68.0	14.8	49.7	69.4	16.5	48.3	69.9	17.2	47.7	70.7	18.3	46.9	71.9	20.2	45.5	72.8	21.8	44.4
	26 / 19	70.2	15.1	49.9	71.5	16.8	48.5	72.0	17.5	47.9	72.7	18.6	47.1	73.7	20.4	45.7	74.4	22.0	44.6
	27 / 19.5	70.8	15.1	51.2	72.1	16.8	49.7	72.5	17.5	49.2	73.2	18.6	48.3	74.2	20.5	46.9	74.9	22.1	45.8
	28 / 21	72.9	15.3	48.8	73.8	17.0	47.3	74.1	17.7	46.7	74.7	18.8	45.8	75.6	20.6	44.4	76.4	22.2	43.2
	30 / 22	74.4	15.5	49.4	75.0	17.1	47.9	75.2	17.8	47.3	75.7	18.9	46.4	76.7	20.7	44.9			
262	22 / 16	76.7	17.2	54.2	78.8	19.0	52.6	79.5	19.8	51.9	80.5	21.0	51.0	81.9	23.1	49.3	82.8	24.9	48.1
	24 / 17	78.0	17.4	57.3	79.8	19.2	55.7	80.5	20.0	55.1	81.4	21.2	54.1	82.8	23.3	52.5	83.8	25.0	51.2
	26 / 19	80.7	17.7	57.2	82.1	19.6	55.6	82.7	20.4	54.9	83.5	21.5	53.9	84.8	23.6	52.3	85.7	25.3	51.0
	27 / 19.5	81.4	17.8	58.7	82.7	19.7	57.1	83.3	20.4	56.4	84.0	21.6	55.5	85.2	23.7	53.9	86.2	25.4	52.6
	28 / 21	83.5	18.1	56.3	84.7	19.9	54.7	85.1	20.7	54.1	85.7	21.9	53.1	86.8	23.9	51.5	87.5	25.5	50.2
	30 / 22	84.9	18.2	58.4	86.0	20.1	56.8	86.4	20.8	56.2	87.0	22.0	55.3	87.8	24.0	53.7	88.4	25.6	52.4
302	22 / 16	90.4	19.0	64.7	92.3	21.2	62.9	93.1	22.1	62.2	94.3	23.5	61.2	96.4	26.1	59.5	98.0	28.3	58.1
	24 / 17	91.9	19.2	68.2	93.8	21.4	66.4	94.5	22.3	65.7	95.7	23.7	64.6	97.7	26.3	62.8	99.4	28.5	61.4
	26 / 19	95.2	19.6	67.4	96.8	21.7	65.6	97.4	22.6	64.9	98.5	24.1	63.9	100.3	26.6	62.1	101.8	28.7	60.6
	27 / 19.5	96.0	19.6	69.2	97.5	21.8	67.4	98.2	22.7	66.7	99.2	24.1	65.6	100.9	26.6	63.8	102.4	28.8	62.4
	28 / 21	98.7	19.9	67.1	99.9	22.0	65.5	100.5	22.9	64.8	101.3	24.3	63.8	102.7	26.8	62.1	103.9	28.9	60.7
	30 / 22	100.5	20.0	71.4	101.6	22.2	69.8	102.0	23.1	69.1	102.7	24.5	68.2	103.8	26.9	66.6			

Ta = ambient air temperature D.B/W.B  
 DB = dry bulb  
 WB = wet bulb  
 kWf = Cooling capacity in kW  
 kWs = sensible cooling capacity (kW)  
 kWe = Compressor power input in kW  
 not all cooling yields take into account the heat dissipated by the fan motors

B108COOLICE01

**ENERGY EFFICIENCY: OPERATION WITH 40% EXTERNAL AIR**

**COOLING PERFORMANCE**

Size	Ta (°C) DB/WB	OUTDOOR AIR TEMPERATURE °C																	
		25			30			32			35			40			44		
		kWf	kWe	kWs	kWf	kWe	kWs	kWf	kWe	kWs	kWf	kWe	kWs	kWf	kWe	kWs	kWf	kWe	kWs
<b>362</b>	22 / 16	102.4	21.3	71.7	104.6	23.4	69.5	105.5	24.4	68.7	106.9	25.9	67.4	109.3	28.7	65.2	111.2	31.2	63.5
	24 / 17	103.8	21.5	75.7	106.0	23.7	73.6	106.9	24.6	72.7	108.3	26.2	71.5	110.7	28.9	69.4	112.7	31.3	67.7
	26 / 19	107.2	21.8	76.1	109.2	24.1	74.0	110.0	25.1	73.2	111.3	26.6	72.0	113.7	29.4	69.9	115.7	31.8	68.3
	27 / 19.5	108.2	21.9	78.2	110.1	24.2	76.1	110.9	25.1	75.3	112.2	26.7	74.1	114.5	29.5	72.0	116.4	32.0	70.4
	28 / 21	111.4	22.1	74.8	113.1	24.3	72.7	113.9	25.3	71.9	114.9	26.9	70.6	116.8	29.9	68.5	118.4	32.5	66.9
	30 / 22	113.8	22.2	76.8	115.4	24.4	74.6	116.0	25.4	73.8	116.9	27.1	72.5	118.5	30.2	70.3	119.7	33.0	68.6
<b>402</b>	22 / 16	115.0	25.1	80.5	117.2	27.7	78.0	118.1	28.8	77.0	119.5	30.5	75.5	122.1	33.5	73.0	124.3	35.9	70.9
	24 / 17	116.9	25.3	84.5	118.8	28.0	82.1	119.7	29.1	81.1	121.1	30.8	79.6	123.7	33.7	77.2	126.0	36.2	75.2
	26 / 19	120.7	25.8	83.3	122.4	28.4	80.9	123.2	29.5	79.9	124.5	31.2	78.5	127.0	34.2	76.1	129.3	36.6	74.1
	27 / 19.5	121.8	25.9	85.3	123.4	28.6	82.9	124.1	29.7	81.9	125.4	31.4	80.5	127.8	34.3	78.1	130.1	36.7	76.2
	28 / 21	125.0	26.3	83.3	126.4	28.9	80.8	127.1	30.0	79.8	128.2	31.7	78.3	130.4	34.6	75.9	132.5	37.0	73.9
	30 / 22	127.2	26.5	89.4	128.5	29.2	86.8	129.1	30.2	85.7	130.2	31.9	84.2	132.2	34.8	81.6	134.1	37.1	79.5

Ta = ambient air temperature D.B/W.B  
 DB = dry bulb  
 WB = wet bulb  
 kWf = Cooling capacity in kW  
 kWs = sensible cooling capacity (kW)  
 kWe = Compressor power input in kW  
 not all cooling yields take into account the heat dissipated by the fan motors

BT08C001CE-01

**ENERGY EFFICIENCY: OPERATION WITH 40% EXTERNAL AIR**

**HEATING PERFORMANCE**

Size	Ta (°C) DB/WB	RETURN AIR TEMPERATURE (D.B.)													
		10		15		18		19		20		21		25	
		kWt	kWe	kWt	kWe	kWt	kWe	kWt	kWe	kWt	kWe	kWt	kWe	kWt	kWe
102	-5 / -5.4	29.0	5.40	29.3	5.83	29.4	6.11	29.5	6.21	29.6	6.31	29.6	6.41	30.0	6.85
	0 / -0.6	33.1	6.18	33.3	6.69	33.4	7.02	33.4	7.14	33.4	7.25	33.5	7.37	33.7	7.86
	5 / 3.9	36.8	7.00	36.9	7.58	36.9	7.94	36.9	8.07	36.9	8.19	36.9	8.32	37.0	8.84
	7 / 6.1	38.6	7.44	38.6	8.04	38.5	8.41	38.5	8.54	38.5	8.67	38.5	8.80	38.6	9.33
	10 / 8.2	40.2	7.87	40.1	8.49	40.1	8.88	40.1	9.01	40.1	9.14	40.0	9.27	40.0	9.81
	15 / 13	43.9	8.93	43.6	9.59	43.5	9.98	43.4	10.1	43.4	10.3	43.4	10.4	43.2	10.9
122	-5 / -5.4	35.1	6.38	35.5	6.91	35.8	7.26	35.9	7.38	36.1	7.50	36.2	7.63	36.8	8.16
	0 / -0.6	38.7	7.13	38.9	7.71	39.1	8.09	39.2	8.23	39.3	8.36	39.4	8.50	39.9	9.09
	5 / 3.9	42.4	7.99	42.6	8.65	42.7	9.06	42.7	9.21	42.8	9.35	42.9	9.50	43.2	10.1
	7 / 6.1	44.4	8.47	44.5	9.17	44.6	9.60	44.7	9.75	44.7	9.90	44.7	10.1	45.0	10.7
	10 / 8.2	46.3	8.97	46.5	9.71	46.6	10.2	46.6	10.3	46.6	10.5	46.6	10.6	46.7	11.3
	15 / 13	51.0	10.2	51.3	11.1	51.4	11.6	51.4	11.7	51.4	11.9	51.3	12.1	51.1	12.7
162	-5 / -5.4	42.0	7.74	40.2	8.02	40.2	8.34	40.3	8.48	40.5	8.62	40.8	8.78	42.9	9.54
	0 / -0.6	45.8	8.43	45.2	8.97	45.3	9.37	45.4	9.52	45.5	9.67	45.6	9.82	46.6	10.5
	5 / 3.9	49.9	9.28	49.9	9.99	50.0	10.4	50.0	10.6	50.1	10.8	50.2	10.9	50.5	11.6
	7 / 6.1	52.0	9.77	52.2	10.5	52.3	11.0	52.3	11.2	52.4	11.3	52.4	11.5	52.6	12.2
	10 / 8.2	54.2	10.3	54.3	11.1	54.4	11.6	54.5	11.8	54.5	11.9	54.5	12.1	54.7	12.8
	15 / 13	59.5	11.6	59.2	12.4	59.3	13.0	59.3	13.2	59.4	13.4	59.4	13.5	59.9	14.4
182	-5 / -5.4	50.7	9.38	50.2	9.92	50.0	10.3	49.9	10.4	49.9	10.5	49.8	10.7	49.8	11.2
	0 / -0.6	54.7	10.1	54.7	10.8	54.7	11.3	54.7	11.4	54.7	11.6	54.8	11.8	55.0	12.5
	5 / 3.9	59.6	11.1	59.6	11.9	59.7	12.4	59.7	12.6	59.7	12.8	59.7	13.0	59.9	13.8
	7 / 6.1	62.3	11.7	62.3	12.6	62.3	13.1	62.3	13.3	62.3	13.5	62.3	13.7	62.4	14.5
	10 / 8.2	65.1	12.3	65.0	13.2	64.9	13.8	64.9	14.0	64.8	14.2	64.8	14.4	64.8	15.2
	15 / 13	72.4	14.0	71.7	14.9	71.3	15.5	71.1	15.7	71.0	15.9	70.9	16.1	70.3	16.9
222	-5 / -5.4	59.2	10.8	57.4	11.3	56.6	11.6	56.4	11.7	56.2	11.9	56.1	12.0	55.6	12.5
	0 / -0.6	63.7	11.6	63.2	12.3	63.1	12.8	63.0	12.9	63.0	13.1	63.1	13.3	63.3	14.0
	5 / 3.9	69.0	12.6	69.1	13.5	69.3	14.1	69.4	14.3	69.5	14.5	69.6	14.8	70.1	15.7
	7 / 6.1	71.9	13.2	72.2	14.2	72.5	14.9	72.6	15.1	72.7	15.3	72.8	15.6	73.4	16.5
	10 / 8.2	74.9	13.9	75.2	14.9	75.5	15.6	75.6	15.9	75.7	16.1	75.8	16.4	76.4	17.4
	15 / 13	82.6	15.6	82.6	16.9	82.7	17.6	82.7	17.9	82.7	18.2	82.8	18.4	83.0	19.5
262	-5 / -5.4	65.5	12.4	69.2	13.6	70.2	14.1	70.3	14.3	70.3	14.5	70.2	14.6	68.6	15.2
	0 / -0.6	73.2	13.5	75.6	14.7	76.4	15.4	76.5	15.6	76.6	15.8	76.7	16.0	76.4	16.8
	5 / 3.9	80.9	14.9	82.1	16.1	82.7	16.8	82.9	17.1	83.1	17.3	83.2	17.6	83.8	18.7
	7 / 6.1	84.8	15.7	85.5	16.9	86.0	17.7	86.2	17.9	86.4	18.2	86.6	18.5	87.5	19.7
	10 / 8.2	88.7	16.5	88.8	17.7	89.2	18.5	89.4	18.8	89.6	19.1	89.8	19.4	91.0	20.7
	15 / 13	97.9	18.6	97.0	19.8	97.1	20.7	97.2	21.0	97.4	21.3	97.7	21.7	99.2	23.2
302	-5 / -5.4	76.5	13.8	76.9	14.7	77.4	15.3	77.6	15.5	77.9	15.7	78.1	15.9	79.3	16.7
	0 / -0.6	84.7	14.9	85.1	15.9	85.6	16.6	85.7	16.8	85.9	17.0	86.1	17.3	87.1	18.3
	5 / 3.9	93.1	16.3	93.5	17.5	93.8	18.2	94.0	18.5	94.1	18.7	94.3	19.0	95.1	20.1
	7 / 6.1	97.4	17.1	97.8	18.3	98.1	19.1	98.2	19.4	98.4	19.7	98.5	20.0	99.2	21.2
	10 / 8.2	101.7	18.0	102.0	19.3	102.3	20.1	102.4	20.4	102.5	20.7	102.7	21.0	103.2	22.3
	15 / 13	112.0	20.1	112.3	21.7	112.4	22.7	112.5	23.0	112.6	23.3	112.7	23.7	113.1	25.1

Ta = Outside air temperature (°C)  
 DB = dry bulb  
 WB = wet bulb  
 kWt = Heating capacity (kW)  
 with coils free of ice  
 kWe = Compressor power input in kW  
 not all thermal yields take into account the heat dissipated by the fan motors

B108C001CB01

**ENERGY EFFICIENCY: OPERATION WITH 40% EXTERNAL AIR**

**HEATING PERFORMANCE**

Size	Ta (°C) DB/WB	RETURN AIR TEMPERATURE (D.B.)													
		10		15		18		19		20		21		25	
		kWt	kWe	kWt	kWe	kWt	kWe	kWt	kWe	kWt	kWe	kWt	kWe	kWt	kWe
362	-5 / -5.4	90.2	16.7	91.9	17.9	92.4	18.5	92.5	18.7	92.5	18.9	92.4	19.1	91.8	19.9
	0 / -0.6	100.5	18.2	100.8	19.4	101.3	20.2	101.4	20.4	101.6	20.7	101.8	21.0	102.8	22.2
	5 / 3.9	110.4	20.0	110.0	21.3	110.3	22.2	110.4	22.5	110.7	22.8	110.9	23.2	112.5	24.6
	7 / 6.1	115.4	21.0	114.7	22.4	114.9	23.3	115.1	23.7	115.3	24.0	115.5	24.4	117.0	25.9
	10 / 8.2	120.2	22.1	119.4	23.5	119.5	24.5	119.6	24.9	119.8	25.2	120.0	25.6	121.2	27.2
	15 / 13	131.5	24.8	130.9	26.5	130.6	27.6	130.5	28.0	130.5	28.3	130.4	28.7	130.3	30.3
402	-5 / -5.4	103.2	19.4	103.9	20.5	104.7	21.3	105.0	21.6	105.3	21.8	105.7	22.1	107.5	23.3
	0 / -0.6	112.5	20.9	113.3	22.3	114.1	23.2	114.4	23.6	114.7	23.9	115.0	24.2	116.5	25.7
	5 / 3.9	122.6	22.9	123.3	24.5	123.9	25.5	124.1	25.9	124.3	26.3	124.6	26.7	125.6	28.2
	7 / 6.1	128.2	24.0	128.6	25.7	129.0	26.8	129.2	27.2	129.3	27.6	129.5	28.0	130.3	29.6
	10 / 8.2	133.8	25.3	133.9	27.1	134.1	28.2	134.2	28.6	134.3	29.0	134.4	29.4	134.9	31.0
	15 / 13	147.8	28.6	146.9	30.5	146.5	31.7	146.4	32.1	146.3	32.5	146.2	32.9	145.8	34.6

Ta = Outside air temperature (°C)  
 DB = dry bulb  
 WB = wet bulb  
 kWt = Heating capacity (kW)  
 with coils free of ice  
 kWe = Compressor power input in kW  
 not all thermal yields take into account the heat dissipated by the fan motors

**INTEGRATED HEATING CAPACITIES**

Air temperature external exchanger inlet °C (D.B. / W.B.)	-5 / -5.4	0 / -0.6	5 / 3.9	OTHERS
Heating capacity multiplication coefficient	0.89	0.88	0.94	1

To obtain the integrated heating capacities (the real heating capacity considering the defrost cycles too), multiply the kWt value in the heating performance tables by the following coefficient.  
 DB = dry bulb  
 WB = wet bulb  
 In case of below zero air ambient temperature with a long period of heat pump operating mode it is necessary to help the evacuation of the water produced during the defrost cycle; this to avoid the formation of ice in the unit basement. Pay attention that the evacuation will not create inconveniences to things or persons.

BT08C001CE-01

**ENERGY EFFICIENCY: OPERATION WITH 60% EXTERNAL AIR**

**COOLING PERFORMANCE**

Size	Ta (°C) DB/WB	OUTDOOR AIR TEMPERATURE °C																	
		25			30			32			35			40			44		
		kWf	kWe	kWs	kWf	kWe	kWs	kWf	kWe	kWs	kWf	kWe	kWs	kWf	kWe	kWs	kWf	kWe	kWs
102	22 / 16	34.6	7.03	23.6	36.6	7.90	22.8	37.3	8.27	22.5	38.5	8.84	22.1	40.5	9.84	21.3	42.1	10.7	20.7
	24 / 17	35.1	7.05	25.0	36.9	7.95	24.2	37.6	8.34	23.9	38.6	8.93	23.5	40.1	9.99	22.7			
	26 / 19	36.0	7.17	25.1	37.6	8.08	24.3	38.3	8.46	24.0	39.3	9.06	23.6	41.0	10.1	22.8			
	27 / 19.5	36.2	7.21	25.8	37.7	8.12	25.0	38.4	8.49	24.7	39.5	9.07	24.3	41.5	10.1	23.5			
	28 / 21	36.7	7.36	24.6	38.1	8.23	23.9	39.0	8.58	23.6	40.6	9.09	23.2	44.0	9.93	22.5			
	30 / 22	37.0	7.49	25.2	38.3	8.32	24.5	39.4	8.63	24.3	41.4	9.07	23.9	46.4	9.75	23.2			
122	22 / 16	40.7	8.82	28.0	42.5	9.90	27.1	43.4	10.4	26.7	44.7	11.1	26.1	47.1	12.3	25.2	49.2	13.3	24.5
	24 / 17	41.2	8.88	29.4	42.8	9.99	28.5	43.6	10.5	28.1	44.8	11.2	27.5	47.2	12.4	26.5	49.4	13.4	25.8
	26 / 19	42.2	9.03	29.0	43.6	10.2	28.0	44.3	10.6	27.6	45.5	11.3	27.1	47.8	12.6	26.1			
	27 / 19.5	42.4	9.08	29.6	43.9	10.2	28.7	44.6	10.7	28.3	45.8	11.4	27.8	48.0	12.6	26.9			
	28 / 21	43.0	9.24	29.0	44.8	10.3	28.2	45.5	10.8	27.8	46.6	11.5	27.4	48.6	12.7	26.5			
	30 / 22	43.4	9.36	31.2	45.4	10.4	30.5	46.2	10.9	30.2	47.3	11.6	29.7	49.1	12.8	29.0			
162	22 / 16	48.0	10.2	33.2	50.0	11.4	32.1	50.9	12.0	31.7	52.3	12.8	31.1	54.9	14.1	30.0	57.2	15.3	29.2
	24 / 17	48.5	10.3	34.9	50.5	11.5	33.9	51.3	12.0	33.5	52.7	12.8	32.8	55.3	14.2	31.8	57.5	15.4	31.0
	26 / 19	49.5	10.4	34.8	51.4	11.7	33.8	52.3	12.2	33.3	53.6	13.0	32.7	56.0	14.4	31.7			
	27 / 19.5	49.8	10.5	35.7	51.7	11.7	34.7	52.5	12.3	34.3	53.8	13.1	33.6	56.2	14.5	32.6			
	28 / 21	50.5	10.6	34.4	52.5	11.9	33.4	53.3	12.4	33.1	54.6	13.2	32.5	56.8	14.6	31.5			
	30 / 22	51.0	10.8	36.0	53.1	12.0	35.0	53.9	12.5	34.6	55.1	13.3	34.0	57.2	14.7	33.1			
182	22 / 16	57.6	11.8	39.5	60.4	13.2	38.2	61.4	13.8	37.7	62.8	14.7	36.9	64.8	16.4	35.6			
	24 / 17	58.2	11.9	41.6	61.0	13.3	40.3	62.0	13.9	39.8	63.3	14.8	39.0	65.2	16.3	37.8			
	26 / 19	59.4	12.1	41.5	62.2	13.5	40.2	63.2	14.1	39.7	64.6	15.0	38.9	66.5	16.4	37.6			
	27 / 19.5	59.8	12.1	42.6	62.5	13.6	41.3	63.5	14.1	40.8	64.9	15.0	40.0	67.0	16.4	38.7			
	28 / 21	60.7	12.3	41.3	63.2	13.7	39.9	64.2	14.2	39.3	65.8	15.1	38.5	68.6	16.6	37.1			
	30 / 22	61.3	12.4	43.6	63.6	13.7	42.1	64.7	14.3	41.5	66.5	15.2	40.6	69.9	16.8	39.1			
222	22 / 16	67.8	14.6	47.0	71.1	16.3	45.6	72.5	17.0	45.0	74.6	18.0	44.2	78.3	19.8	42.8			
	24 / 17	68.5	14.8	49.8	71.7	16.5	48.4	73.0	17.1	47.8	75.0	18.2	47.0	78.4	20.0	45.6			
	26 / 19	69.9	15.1	49.5	72.9	16.7	48.1	74.1	17.4	47.6	75.9	18.5	46.7	78.9	20.2	45.3			
	27 / 19.5	70.2	15.1	50.7	73.1	16.8	49.3	74.3	17.5	48.8	76.1	18.5	47.9	79.1	20.3	46.5			
	28 / 21	71.3	15.3	48.8	73.8	17.0	47.3	74.9	17.7	46.7	76.7	18.7	45.8	80.0	20.5	44.4			
	30 / 22	72.0	15.5	50.3	74.2	17.2	48.8	75.2	17.8	48.2	77.1	18.9	47.3	80.7	20.6	45.8			
262	22 / 16	77.9	17.2	54.3	81.8	19.0	52.7	83.4	19.7	52.1	85.8	20.9	51.1	89.8	22.9	49.5	93.0	24.5	48.2
	24 / 17	78.6	17.4	57.1	82.4	19.2	55.5	83.9	19.9	54.9	86.2	21.1	54.0	90.1	23.1	52.4			
	26 / 19	80.2	17.8	56.4	83.7	19.6	54.8	85.2	20.3	54.2	87.3	21.4	53.2	90.9	23.4	51.7			
	27 / 19.5	80.6	17.8	57.8	84.1	19.7	56.2	85.5	20.4	55.6	87.6	21.5	54.7	91.1	23.5	53.1			
	28 / 21	81.8	18.1	56.3	85.2	19.9	54.7	86.6	20.7	54.0	88.6	21.8	53.1	91.9	23.7	51.5			
	30 / 22	82.7	18.2	60.0	86.1	20.1	58.4	87.4	20.8	57.8	89.3	22.0	56.8	92.4	23.8	55.2			
302	22 / 16	91.5	19.0	64.6	95.7	21.1	62.9	97.6	22.0	62.3	100.7	23.5	61.2	106.3	26.0	59.5			
	24 / 17	92.1	19.2	68.1	96.7	21.3	66.3	98.6	22.2	65.6	101.5	23.7	64.6	106.5	26.2	62.8			
	26 / 19	93.9	19.5	67.3	98.6	21.7	65.5	100.5	22.6	64.8	103.2	24.0	63.7	107.6	26.5	61.9			
	27 / 19.5	94.5	19.6	69.0	99.1	21.8	67.2	100.9	22.7	66.5	103.6	24.1	65.4	108.0	26.5	63.7			
	28 / 21	96.6	19.8	67.1	100.6	22.0	65.4	102.2	22.9	64.8	104.9	24.3	63.8	109.6	26.8	62.1			
	30 / 22	98.3	20.0	71.7	101.5	22.1	70.1	103.1	23.0	69.4	105.7	24.4	68.5	110.9	26.9	66.9			

Ta = ambient air temperature D.B/W.B  
 DB = dry bulb  
 WB = wet bulb  
 kWf = Cooling capacity in kW  
 kWs = sensible cooling capacity (kW)  
 kWe = Compressor power input in kW  
 not all cooling yields take into account the heat dissipated by the fan motors

BI08COOLICE01

**ENERGY EFFICIENCY: OPERATION WITH 60% EXTERNAL AIR**

**COOLING PERFORMANCE**

Size	Ta (°C) DB/WB	OUTDOOR AIR TEMPERATURE °C																	
		25			30			32			35			40			44		
		kWf	kWe	kWs	kWf	kWe	kWs	kWf	kWe	kWs	kWf	kWe	kWs	kWf	kWe	kWs	kWf	kWe	kWs
<b>362</b>	22 / 16	103.6	21.1	71.7	108.8	23.4	69.6	110.9	24.4	68.7	114.1	26.0	67.4	119.5	28.6	65.3	123.9	30.9	63.5
	24 / 17	104.4	21.4	75.7	109.8	23.6	73.6	111.9	24.6	72.7	115.1	26.2	71.5	120.5	28.9	69.4	124.8	31.3	67.7
	26 / 19	106.5	21.8	76.0	111.4	24.1	74.0	113.5	25.0	73.2	116.7	26.6	72.0	122.4	29.4	70.0	127.1	31.9	68.3
	27 / 19.5	107.1	21.9	78.2	111.8	24.2	76.2	113.9	25.1	75.4	117.1	26.7	74.1	122.9	29.5	72.1	127.9	31.9	70.5
	28 / 21	109.0	22.1	74.9	112.8	24.5	72.8	114.6	25.5	72.0	117.9	27.1	70.7	124.3	29.8	68.7			
	30 / 22	110.5	22.2	77.1	113.3	24.7	75.0	115.0	25.8	74.2	118.2	27.3	72.9	125.2	30.0	70.8			
<b>402</b>	22 / 16	116.4	25.0	80.5	121.8	27.6	78.0	124.2	28.7	77.0	128.0	30.3	75.5	134.8	33.1	73.0	140.8	35.4	71.0
	24 / 17	117.6	25.3	84.6	122.8	27.8	82.2	125.1	28.9	81.2	128.8	30.5	79.8	135.5	33.4	77.4	141.3	35.7	75.5
	26 / 19	119.9	25.8	83.2	125.0	28.4	80.9	127.2	29.4	79.9	130.7	31.1	78.5	137.0	33.9	76.2			
	27 / 19.5	120.5	25.9	85.3	125.5	28.5	82.9	127.7	29.6	82.0	131.2	31.2	80.6	137.5	34.0	78.2			
	28 / 21	122.3	26.2	83.3	127.3	28.9	80.8	129.4	29.9	79.8	132.8	31.6	78.3	138.9	34.3	75.8			
	30 / 22	123.5	26.4	89.4	128.5	29.1	86.8	130.6	30.2	85.7	134.0	31.8	84.1	139.9	34.5	81.5			

Ta = ambient air temperature D.B/W.B  
 DB = dry bulb  
 WB = wet bulb  
 kWf = Cooling capacity in kW  
 kWs = sensible cooling capacity (kW)  
 kWe = Compressor power input in kW  
 not all cooling yields take into account the heat dissipated by the fan motors

BT08C001CE-01

**ENERGY EFFICIENCY: OPERATION WITH 60% EXTERNAL AIR**

**HEATING PERFORMANCE**

Size	Ta (°C) DB/WB	RETURN AIR TEMPERATURE (D.B.)													
		10		15		18		19		20		21		25	
		kWt	kWe	kWt	kWe	kWt	kWe	kWt	kWe	kWt	kWe	kWt	kWe	kWt	kWe
102	-5 / -5.4	29.7	5.09	30.4	5.38	30.7	5.56	30.9	5.63	31.0	5.69	31.1	5.75	31.5	6.02
	0 / -0.6	33.6	5.92	34.1	6.28	34.4	6.50	34.5	6.58	34.6	6.66	34.7	6.74	35.1	7.06
	5 / 3.9	37.1	6.83	37.4	7.25	37.6	7.50	37.7	7.59	37.8	7.68	37.9	7.77	38.2	8.13
	7 / 6.1	38.7	7.33	38.9	7.76	39.1	8.03	39.2	8.12	39.3	8.21	39.3	8.30	39.6	8.68
	10 / 8.2	40.1	7.83	40.4	8.28	40.5	8.56	40.6	8.65	40.6	8.75	40.7	8.84	41.0	9.23
	15 / 13	43.4	9.07	43.5	9.56	43.6	9.85	43.6	9.95	43.6	10.1	43.7	10.1	43.8	10.5
122	-5 / -5.4	36.2	6.07	37.2	6.45	37.5	6.66	37.5	6.72	37.6	6.79	37.6	6.85	37.5	7.09
	0 / -0.6	39.4	6.85	40.1	7.28	40.5	7.54	40.6	7.63	40.7	7.72	40.8	7.81	41.2	8.17
	5 / 3.9	42.7	7.80	43.3	8.29	43.7	8.60	43.8	8.71	44.0	8.81	44.1	8.92	44.8	9.37
	7 / 6.1	44.4	8.34	45.0	8.87	45.4	9.20	45.6	9.31	45.7	9.42	45.9	9.54	46.5	10.0
	10 / 8.2	46.1	8.91	46.7	9.47	47.1	9.82	47.3	9.94	47.4	10.1	47.6	10.2	48.2	10.7
	15 / 13	50.2	10.4	51.0	11.0	51.4	11.4	51.5	11.5	51.6	11.7	51.7	11.8	51.9	12.3
162	-5 / -5.4			42.4	7.55	42.8	7.76	43.0	7.84	43.1	7.91	43.2	7.98	43.4	8.27
	0 / -0.6	45.9	8.05	46.6	8.49	47.0	8.76	47.2	8.85	47.3	8.95	47.4	9.04	47.8	9.42
	5 / 3.9	50.0	9.06	50.7	9.58	51.1	9.90	51.2	10.0	51.3	10.1	51.5	10.2	52.0	10.7
	7 / 6.1	52.1	9.63	52.7	10.2	53.0	10.5	53.2	10.6	53.3	10.8	53.5	10.9	54.1	11.4
	10 / 8.2	54.1	10.2	54.6	10.8	55.0	11.2	55.1	11.3	55.2	11.4	55.4	11.6	56.1	12.1
	15 / 13	58.8	11.8	59.0	12.4	59.4	12.8	59.5	13.0	59.7	13.1	59.9	13.2	60.8	13.9
182	-5 / -5.4			51.6	9.20	51.9	9.44	52.0	9.52	52.2	9.61	52.3	9.69	53.0	10.1
	0 / -0.6	55.2	9.68	55.9	10.2	56.4	10.5	56.6	10.6	56.7	10.7	56.9	10.9	57.8	11.3
	5 / 3.9	59.8	10.8	60.5	11.4	61.0	11.8	61.2	11.9	61.3	12.1	61.5	12.2	62.3	12.8
	7 / 6.1	62.4	11.5	63.0	12.2	63.4	12.6	63.5	12.7	63.7	12.8	63.8	13.0	64.5	13.5
	10 / 8.2	64.9	12.2	65.4	12.9	65.7	13.3	65.9	13.5	66.0	13.6	66.1	13.8	66.7	14.3
	15 / 13	71.4	14.2	71.5	14.9	71.5	15.3	71.5	15.5	71.5	15.6	71.5	15.8	71.6	16.3
222	-5 / -5.4			59.9	10.6	61.0	10.9	61.2	11.0	61.3	11.1	61.3	11.2	60.2	11.4
	0 / -0.6	62.8	10.9	65.0	11.6	65.9	12.0	66.2	12.1	66.4	12.3	66.6	12.4	66.9	12.8
	5 / 3.9	69.0	12.3	70.2	13.0	71.0	13.4	71.3	13.6	71.5	13.7	71.8	13.9	72.9	14.5
	7 / 6.1	72.0	13.0	73.0	13.8	73.7	14.2	73.9	14.4	74.2	14.6	74.5	14.7	75.7	15.4
	10 / 8.2	74.9	13.8	75.7	14.6	76.3	15.1	76.6	15.3	76.8	15.5	77.1	15.6	78.4	16.4
	15 / 13	81.4	15.9	82.2	16.8	82.7	17.4	82.9	17.6	83.1	17.8	83.3	18.0	84.2	18.8
262	-5 / -5.4			72.3	12.8	73.3	13.1	73.8	13.2	74.3	13.4	74.8	13.5	77.5	14.2
	0 / -0.6	76.1	13.2	77.8	14.0	79.0	14.4	79.5	14.6	79.9	14.8	80.4	14.9	82.3	15.6
	5 / 3.9	81.5	14.6	83.5	15.5	84.7	16.0	85.1	16.2	85.5	16.4	86.0	16.6	87.7	17.4
	7 / 6.1	84.6	15.5	86.4	16.4	87.6	17.0	88.0	17.2	88.4	17.4	88.8	17.6	90.6	18.5
	10 / 8.2	87.9	16.4	89.3	17.3	90.4	17.9	90.8	18.1	91.2	18.4	91.6	18.6	93.5	19.5
	15 / 13	96.4	18.9	96.4	19.7	97.1	20.4	97.5	20.6	97.9	20.9	98.4	21.2	100.9	22.4
302	-5 / -5.4			81.6	14.0	80.1	14.1	80.0	14.2	80.2	14.3	80.6	14.5	84.5	15.2
	0 / -0.6	90.9	14.8	88.2	15.2	88.0	15.5	88.2	15.7	88.5	15.8	88.9	16.0	91.6	16.8
	5 / 3.9	95.0	16.1	95.2	16.8	95.8	17.3	96.1	17.5	96.4	17.7	96.8	17.9	98.8	18.7
	7 / 6.1	97.9	16.9	98.9	17.8	99.7	18.4	100.0	18.6	100.4	18.8	100.7	19.0	102.4	19.9
	10 / 8.2	101.2	17.8	102.6	18.8	103.5	19.5	103.8	19.7	104.2	19.9	104.5	20.1	106.0	21.0
	15 / 13	110.5	20.4	111.7	21.6	112.5	22.3	112.7	22.6	113.0	22.8	113.3	23.1	114.6	24.1

Ta = Outside air temperature (°C)  
 DB = dry bulb  
 WB = wet bulb  
 kWt = Heating capacity (kW)  
 with coils free of ice  
 kWe = Compressor power input in kW  
 not all thermal yields take into account the heat dissipated by the fan motors

B108CO01CB01

**ENERGY EFFICIENCY: OPERATION WITH 60% EXTERNAL AIR**

**HEATING PERFORMANCE**

Size	Ta (°C) DB/WB	RETURN AIR TEMPERATURE (D.B.)													
		10		15		18		19		20		21		25	
		kWt	kWe	kWt	kWe	kWt	kWe	kWt	kWe	kWt	kWe	kWt	kWe	kWt	kWe
362	-5 / -5.4	92.8	16.1	96.0	17.0	97.2	17.4	97.4	17.5	97.6	17.6	97.8	17.8	97.6	18.2
	0 / -0.6	102.1	17.7	103.9	18.5	105.1	19.1	105.5	19.3	106.0	19.5	106.5	19.7	108.4	20.5
	5 / 3.9	111.0	19.6	111.9	20.6	113.1	21.2	113.6	21.5	114.1	21.7	114.7	22.0	117.4	23.1
	7 / 6.1	115.4	20.8	116.1	21.8	117.2	22.5	117.6	22.7	118.1	23.0	118.7	23.3	121.5	24.5
	10 / 8.2	119.6	22.0	120.2	23.0	121.2	23.8	121.6	24.1	122.1	24.3	122.6	24.6	125.1	25.8
	15 / 13	129.3	25.1	130.2	26.4	130.8	27.2	131.0	27.5	131.3	27.8	131.5	28.1	132.5	29.3
402	-5 / -5.4	106.2	18.7	108.8	19.5	110.4	20.0	111.0	20.2	111.6	20.3	112.2	20.5	114.8	21.4
	0 / -0.6	114.4	20.3	117.1	21.3	118.9	22.0	119.5	22.2	120.1	22.5	120.7	22.7	123.4	23.8
	5 / 3.9	123.3	22.4	125.8	23.7	127.4	24.5	128.0	24.8	128.6	25.1	129.1	25.3	131.6	26.6
	7 / 6.1	128.1	23.7	130.4	25.0	131.8	25.9	132.4	26.2	132.9	26.5	133.4	26.8	135.7	28.1
	10 / 8.2	132.9	25.1	134.9	26.5	136.2	27.4	136.7	27.7	137.1	28.0	137.6	28.3	139.6	29.6
	15 / 13	144.8	28.8	146.0	30.3	146.7	31.3	147.0	31.6	147.2	31.9	147.5	32.2	148.6	33.5

Ta = Outside air temperature (°C)  
 DB = dry bulb  
 WB = wet bulb  
 kWt = Heating capacity (kW)  
 with coils free of ice  
 kWe = Compressor power input in kW  
 not all thermal yields take into account the heat dissipated by the fan motors

**INTEGRATED HEATING CAPACITIES**

Air temperature external exchanger inlet °C (D.B. / W.B.)	-5 / -5.4	0 / -0.6	5 / 3.9	OTHERS
Heating capacity multiplication coefficient	0.89	0.88	0.94	1

To obtain the integrated heating capacities (the real heating capacity considering the defrost cycles too), multiply the kWt value in the heating performance tables by the following coefficient.  
 DB = dry bulb  
 WB = wet bulb  
 In case of below zero air ambient temperature with a long period of heat pump operating mode it is necessary to help the evacuation of the water produced during the defrost cycle; this to avoid the formation of ice in the unit basement. Pay attention that the evacuation will not create inconveniences to things or persons.

**ENERGY EFFICIENCY: OPERATION WITH 80% EXTERNAL AIR**

**COOLING PERFORMANCE**

Size	Ta (°C) DB/WB	OUTDOOR AIR TEMPERATURE °C																	
		25			30			32			35			40			44		
		kWf	kWe	kWs	kWf	kWe	kWs	kWf	kWe	kWs	kWf	kWe	kWs	kWf	kWe	kWs	kWf	kWe	kWs
102	22 / 16	35.0	7.03	23.4	37.9	7.91	22.6	39.1	8.29	22.3	40.8	8.87	21.8	43.7	9.90	21.0			
	24 / 17	35.7	7.02	24.7	38.0	7.96	24.0	39.1	8.34	23.7	40.7	8.94	23.2	43.8	9.96	22.4			
	26 / 19	35.7	7.16	24.7	38.3	8.09	23.9	39.3	8.48	23.6	41.0	9.07	23.2	43.9	10.1	22.4			
	27 / 19.5	35.5	7.23	25.3	38.3	8.13	24.5	39.5	8.51	24.2	41.1	9.11	23.8	43.9	10.1	23.0			
	28 / 21	34.0	7.52	24.5	38.5	8.28	23.8	39.9	8.64	23.5	41.8	9.21	23.1						
	30 / 22	32.5	7.78	25.6	38.6	8.40	24.9	40.4	8.73	24.6	42.4	9.28	24.2						
122	22 / 16	41.0	8.84	28.0	44.2	10.0	27.1	45.5	10.5	26.7	47.5	11.2	26.1	50.7	12.5	25.2			
	24 / 17	41.3	8.89	29.3	44.4	10.1	28.4	45.7	10.6	28.0	47.6	11.3	27.4	50.8	12.6	26.5			
	26 / 19	41.7	9.04	28.9	44.7	10.2	28.1	45.9	10.7	27.7	47.8	11.5	27.2	51.0	12.8	26.4			
	27 / 19.5	41.7	9.09	29.6	44.7	10.3	28.7	45.9	10.8	28.4	47.8	11.5	27.9	51.0	12.8	27.1			
	28 / 21	41.7	9.26	28.8	44.8	10.5	28.0	46.0	11.0	27.7	47.9	11.7	27.2						
	30 / 22	41.7	9.39	30.3	44.9	10.6	29.5	46.1	11.1	29.2	47.9	11.9	28.8						
162	22 / 16	48.4	10.2	33.1	52.4	11.4	32.1	53.9	11.9	31.7	56.1	12.7	31.1	59.5	14.1	30.1			
	24 / 17	48.4	10.3	35.0	52.4	11.5	34.0	53.9	12.0	33.6	56.1	12.8	32.9	59.5	14.2	31.9			
	26 / 19	48.7	10.5	35.0	52.5	11.7	33.9	54.0	12.2	33.5	56.2	13.0	32.9	59.7	14.4	31.9			
	27 / 19.5	48.8	10.5	36.0	52.6	11.7	34.9	54.1	12.3	34.5	56.2	13.1	33.9	59.7	14.5	32.9			
	28 / 21	49.3	10.6	34.5	52.8	11.9	33.6	54.3	12.4	33.2	56.4	13.2	32.6	59.8	14.6	31.6			
	30 / 22	49.7	10.7	36.1	53.1	12.0	35.2	54.4	12.5	34.8	56.5	13.3	34.2	59.9	14.7	33.3			
182	22 / 16	58.2	11.9	39.8	62.5	13.2	38.7	64.1	13.8	38.3	66.5	14.7	37.7	70.1	16.3	36.7			
	24 / 17	58.4	11.9	42.1	62.6	13.3	41.1	64.2	13.9	40.7	66.5	14.8	40.1	70.2	16.4	39.0			
	26 / 19	59.0	12.0	42.0	63.0	13.5	40.8	64.5	14.1	40.3	66.8	15.0	39.5	70.5	16.5	38.3			
	27 / 19.5	59.1	12.1	43.2	63.1	13.5	42.0	64.6	14.1	41.4	66.9	15.1	40.7						
	28 / 21	59.7	12.2	41.9	63.6	13.7	40.3	65.1	14.3	39.7	67.3	15.2	38.7						
	30 / 22	60.2	12.4	44.6	64.0	13.7	42.8	65.4	14.3	42.1	67.5	15.2	41.0						
222	22 / 16	68.4	14.6	47.1	73.8	16.3	45.6	75.9	17.0	45.1	79.1	18.0	44.2	84.4	19.9	42.8			
	24 / 17	68.8	14.8	49.8	73.7	16.4	48.4	75.8	17.1	47.8	79.2	18.2	47.0						
	26 / 19	69.6	15.0	49.3	73.8	16.8	47.9	75.8	17.5	47.4	79.3	18.5	46.5						
	27 / 19.5	69.7	15.1	50.5	73.9	16.8	49.1	75.9	17.5	48.5	79.4	18.6	47.7						
	28 / 21	70.3	15.3	48.7	74.4	17.0	47.2	76.3	17.7	46.7	79.7	18.8	45.8						
	30 / 22	70.7	15.4	50.7	74.8	17.1	49.2	76.7	17.8	48.6	79.9	18.9	47.7						
262	22 / 16	78.4	17.1	54.2	85.0	18.9	52.6	87.5	19.7	52.0	91.3	20.8	51.0	97.3	22.7	49.5			
	24 / 17	78.9	17.3	57.0	85.1	19.2	55.4	87.6	19.9	54.8	91.3	21.0	53.9	97.5	22.9	52.3			
	26 / 19	79.6	17.7	56.5	85.4	19.6	54.9	87.7	20.3	54.2	91.4	21.4	53.3	97.6	23.3	51.7			
	27 / 19.5	79.8	17.8	57.9	85.4	19.6	56.3	87.8	20.4	55.7	91.4	21.5	54.7	97.6	23.5	53.1			
	28 / 21	80.1	18.1	56.3	85.7	19.8	54.7	88.1	20.5	54.1	91.6	21.8	53.1						
	30 / 22	80.2	18.2	59.8	86.0	19.8	58.2	88.3	20.6	57.6	91.7	21.9	56.6						
302	22 / 16	92.8	19.0	64.6	99.8	21.1	62.9	102.7	22.0	62.3	107.2	23.3	61.3	115.1	25.6	59.6			
	24 / 17	92.8	19.2	67.9	100.0	21.3	66.2	102.9	22.2	65.5	107.3	23.5	64.5						
	26 / 19	93.3	19.5	66.7	100.5	21.7	65.0	103.4	22.5	64.3	107.7	23.9	63.3						
	27 / 19.5	93.4	19.6	68.4	100.7	21.7	66.7	103.5	22.6	66.0	107.8	24.0	65.0						
	28 / 21	94.1	19.8	67.1	101.2	22.0	65.4	104.0	22.9	64.8	108.2	24.2	63.7						
	30 / 22	94.6	19.9	72.5	101.6	22.1	70.9	104.4	23.0	70.2	108.5	24.3	69.2						

Ta = ambient air temperature D.B/W.B  
 DB = dry bulb  
 WB = wet bulb  
 kWf = Cooling capacity in kW  
 kWs = sensible cooling capacity (kW)  
 kWe = Compressor power input in kW  
 not all cooling yields take into account the heat dissipated by the fan motors

B108COOLICE01

**ENERGY EFFICIENCY: OPERATION WITH 80% EXTERNAL AIR**

**COOLING PERFORMANCE**

Size	Ta (°C) DB/WB	OUTDOOR AIR TEMPERATURE °C																	
		25			30			32			35			40			44		
		kWf	kWe	kWs	kWf	kWe	kWs	kWf	kWe	kWs	kWf	kWe	kWs	kWf	kWe	kWs	kWf	kWe	kWs
<b>362</b>	22 / 16	104.3	21.4	71.8	111.2	23.6	69.6	114.4	24.5	68.7	119.7	25.8	67.3	129.8	28.2	65.1			
	24 / 17	104.8	21.5	75.8	112.0	23.8	73.6	115.4	24.7	72.8	120.8	26.1	71.4	131.2	28.6	69.2			
	26 / 19	105.6	21.8	75.4	113.3	24.1	73.2	116.8	25.1	72.4	122.4	26.6	71.1	132.8	29.3	68.9			
	27 / 19.5	105.8	21.9	77.5	113.6	24.2	75.3	117.0	25.2	74.4	122.6	26.7	73.1	132.9	29.5	70.9			
	28 / 21	106.2	22.2	74.8	114.2	24.5	72.6	117.6	25.5	71.8	123.0	27.1	70.5	132.8	30.1	68.3			
	30 / 22	106.4	22.4	78.8	114.5	24.6	76.5	117.8	25.7	75.7	123.1	27.3	74.3	132.2	30.5	72.1			
<b>402</b>	22 / 16	118.0	25.0	80.6	126.9	27.4	78.1	130.7	28.5	77.2	136.5	30.1	75.7	146.5	32.9	73.2			
	24 / 17	118.2	25.2	84.3	127.5	27.8	81.9	131.2	28.9	80.9	136.9	30.5	79.4	146.5	33.2	77.0			
	26 / 19	118.9	25.7	82.3	128.2	28.5	79.9	131.9	29.5	78.9	137.5	31.1	77.5	146.6	33.7	75.1			
	27 / 19.5	119.1	25.8	84.2	128.4	28.6	81.7	132.0	29.7	80.8	137.5	31.3	79.3	146.6	33.8	76.9			
	28 / 21	119.7	26.2	83.3	128.6	28.9	80.8	132.2	30.0	79.8	137.7	31.6	78.3	147.1	34.2	75.8			
	30 / 22	120.3	26.3	91.4	128.6	29.0	88.8	132.1	30.1	87.8	137.7	31.7	86.2	147.4	34.3	83.6			

Ta = ambient air temperature D.B/W.B  
 DB = dry bulb  
 WB = wet bulb  
 kWf = Cooling capacity in kW  
 kWs = sensible cooling capacity (kW)  
 kWe = Compressor power input in kW  
 not all cooling yields take into account the heat dissipated by the fan motors

**ENERGY EFFICIENCY: OPERATION WITH 80% EXTERNAL AIR**

**HEATING PERFORMANCE**

Size	Ta (°C) DB/WB	RETURN AIR TEMPERATURE (D.B.)													
		10		15		18		19		20		21		25	
		kWt	kWe	kWt	kWe	kWt	kWe	kWt	kWe	kWt	kWe	kWt	kWe	kWt	kWe
102	-5 / -5.4					31.7	5.08	31.9	5.11	32.1	5.15	32.2	5.18	32.9	5.33
	0 / -0.6	34.0	5.67	34.8	5.89	35.3	6.03	35.4	6.08	35.6	6.12	35.7	6.17	36.4	6.37
	5 / 3.9	37.3	6.67	37.9	6.93	38.3	7.09	38.4	7.14	38.6	7.20	38.7	7.25	39.3	7.48
	7 / 6.1	38.7	7.22	39.3	7.49	39.7	7.67	39.8	7.72	40.0	7.78	40.1	7.84	40.6	8.08
	10 / 8.2	40.1	7.78	40.6	8.07	41.0	8.25	41.1	8.31	41.2	8.37	41.3	8.43	41.9	8.68
	15 / 13	42.9	9.22	43.3	9.53	43.6	9.72	43.7	9.79	43.9	9.85	44.0	9.91	44.4	10.2
122	-5 / -5.4					39.2	6.17	39.5	6.22	39.7	6.27	39.9	6.31	40.8	6.50
	0 / -0.6	40.0	6.58	41.1	6.86	41.8	7.05	42.0	7.11	42.3	7.17	42.6	7.24	43.6	7.51
	5 / 3.9	42.9	7.62	43.9	7.95	44.6	8.16	44.9	8.23	45.1	8.31	45.4	8.38	46.5	8.71
	7 / 6.1	44.4	8.22	45.4	8.58	46.1	8.81	46.4	8.88	46.6	8.96	46.9	9.04	47.9	9.38
	10 / 8.2	45.9	8.85	47.0	9.24	47.7	9.49	47.9	9.57	48.1	9.65	48.4	9.73	49.4	10.1
	15 / 13	49.5	10.5	50.8	11.0	51.5	11.3	51.7	11.4	51.9	11.4	52.1	11.5	52.8	11.9
162	-5 / -5.4									45.5	7.30	45.9	7.36	47.5	7.62
	0 / -0.6	46.6	7.75	47.9	8.03	48.7	8.21	49.0	8.27	49.3	8.34	49.6	8.40	50.9	8.68
	5 / 3.9	50.3	8.85	51.5	9.20	52.2	9.42	52.5	9.49	52.8	9.57	53.1	9.64	54.2	9.96
	7 / 6.1	52.1	9.49	53.2	9.86	54.0	10.1	54.2	10.2	54.5	10.3	54.8	10.3	56.0	10.7
	10 / 8.2	53.9	10.2	54.9	10.6	55.6	10.8	55.9	10.9	56.2	11.0	56.5	11.1	57.7	11.4
	15 / 13	58.0	11.9	58.7	12.4	59.4	12.6	59.7	12.7	60.0	12.8	60.3	12.9	61.8	13.4
182	-5 / -5.4					53.9	8.75	54.0	8.78	54.2	8.81	54.3	8.84	54.6	8.95
	0 / -0.6	56.0	9.33	57.3	9.64	58.0	9.83	58.2	9.89	58.5	9.95	58.7	10.0	59.6	10.3
	5 / 3.9	60.2	10.6	61.4	11.0	62.2	11.2	62.5	11.3	62.7	11.4	63.0	11.5	64.2	11.8
	7 / 6.1	62.4	11.4	63.6	11.8	64.3	12.0	64.6	12.1	64.9	12.2	65.2	12.3	66.4	12.7
	10 / 8.2	64.7	12.2	65.8	12.6	66.5	12.9	66.7	13.0	67.0	13.1	67.3	13.2	68.4	13.6
	15 / 13	70.4	14.4	71.2	14.9	71.6	15.1	71.8	15.2	72.0	15.3	72.1	15.4	72.9	15.8
222	-5 / -5.4													66.6	10.7
	0 / -0.6	64.8	10.6	66.8	11.0	68.1	11.3	68.5	11.4	69.0	11.5	69.4	11.6	71.4	11.9
	5 / 3.9	69.6	12.0	71.4	12.5	72.6	12.8	73.1	12.9	73.5	13.0	74.0	13.1	75.9	13.5
	7 / 6.1	72.1	12.8	73.8	13.3	75.0	13.7	75.4	13.8	75.8	13.9	76.3	14.0	78.2	14.5
	10 / 8.2	74.5	13.7	76.1	14.3	77.2	14.6	77.7	14.7	78.1	14.8	78.5	15.0	80.4	15.5
	15 / 13	80.4	16.1	81.8	16.7	82.8	17.1	83.1	17.3	83.5	17.4	83.8	17.5	85.5	18.1
262	-5 / -5.4					77.6	12.4	78.3	12.5	78.9	12.5	79.5	12.6	81.6	12.9
	0 / -0.6	76.4	12.7	80.1	13.3	82.2	13.6	82.9	13.8	83.5	13.9	84.2	14.0	86.7	14.5
	5 / 3.9	82.0	14.3	85.0	14.9	86.8	15.3	87.5	15.5	88.1	15.6	88.8	15.7	91.5	16.3
	7 / 6.1	84.8	15.3	87.5	15.9	89.2	16.3	89.9	16.5	90.5	16.6	91.1	16.8	93.8	17.4
	10 / 8.2	87.4	16.2	89.9	16.9	91.6	17.4	92.2	17.5	92.8	17.7	93.4	17.8	96.0	18.5
	15 / 13	93.6	18.9	95.8	19.6	97.3	20.1	97.8	20.3	98.3	20.5	98.9	20.7	101.2	21.4
302	-5 / -5.4													90.0	14.0
	0 / -0.6	88.3	14.0	90.5	14.5	92.0	14.7	92.6	14.9	93.2	15.0	93.8	15.1	96.3	15.5
	5 / 3.9	94.4	15.7	96.7	16.2	98.3	16.6	98.8	16.7	99.4	16.8	100.0	17.0	102.6	17.5
	7 / 6.1	97.7	16.7	99.9	17.3	101.5	17.7	102.1	17.8	102.6	17.9	103.2	18.1	105.7	18.7
	10 / 8.2	100.9	17.8	103.2	18.4	104.7	18.8	105.3	19.0	105.8	19.1	106.4	19.3	108.8	19.9
	15 / 13	108.9	20.7	111.1	21.5	112.5	22.0	113.0	22.2	113.5	22.4	114.0	22.5	116.2	23.2

Ta = Outside air temperature (°C)  
 DB = dry bulb  
 WB = wet bulb  
 kWt = Heating capacity (kW)  
 with coils free of ice  
 kWe = Compressor power input in kW  
 not all thermal yields take into account the heat dissipated by the fan motors

B108CO01CB01

**ENERGY EFFICIENCY: OPERATION WITH 80% EXTERNAL AIR**

**HEATING PERFORMANCE**

Size	Ta (°C) DB/WB	RETURN AIR TEMPERATURE (D.B.)													
		10		15		18		19		20		21		25	
		kWt	kWe	kWt	kWe	kWt	kWe	kWt	kWe	kWt	kWe	kWt	kWe	kWt	kWe
362	-5 / -5.4					102.2	16.5	102.7	16.6	103.2	16.7	103.5	16.7	104.2	16.9
	0 / -0.6	103.6	17.1	107.0	17.8	109.2	18.2	109.9	18.3	110.6	18.4	111.3	18.6	114.3	19.1
	5 / 3.9	111.4	19.3	114.0	19.9	116.0	20.4	116.8	20.6	117.6	20.7	118.5	20.9	122.4	21.7
	7 / 6.1	115.3	20.5	117.5	21.2	119.5	21.7	120.3	21.9	121.1	22.1	121.9	22.3	125.9	23.2
	10 / 8.2	118.9	21.8	121.1	22.6	122.9	23.1	123.6	23.3	124.4	23.5	125.2	23.7	128.9	24.6
	15 / 13	127.4	25.4	129.6	26.3	131.0	26.9	131.5	27.1	132.0	27.3	132.5	27.5	134.8	28.4
402	-5 / -5.4			113.4	18.5	116.1	18.9	117.0	19.0	118.0	19.2	118.9	19.3	122.7	19.8
	0 / -0.6	116.2	19.6	120.6	20.4	123.4	20.9	124.4	21.1	125.4	21.3	126.3	21.4	130.3	22.2
	5 / 3.9	123.9	22.0	128.1	22.9	130.8	23.5	131.7	23.7	132.6	23.9	133.5	24.1	137.4	25.0
	7 / 6.1	128.0	23.4	132.0	24.4	134.5	25.0	135.4	25.2	136.2	25.5	137.1	25.7	140.8	26.6
	10 / 8.2	132.1	24.9	135.8	26.0	138.2	26.6	139.0	26.8	139.8	27.1	140.6	27.3	144.0	28.3
	15 / 13	142.3	29.1	145.1	30.2	146.9	30.9	147.5	31.1	148.1	31.3	148.7	31.6	151.4	32.5

Ta = Outside air temperature (°C)  
 DB = dry bulb  
 WB = wet bulb  
 kWt = Heating capacity (kW)  
 with coils free of ice  
 kWe = Compressor power input in kW  
 not all thermal yields take into account the heat dissipated by the fan motors

**INTEGRATED HEATING CAPACITIES**

Air temperature external exchanger inlet °C (D.B. / W.B.)	-5 / -5.4	0 / -0.6	5 / 3.9	OTHERS
Heating capacity multiplication coefficient	0.89	0.88	0.94	1

To obtain the integrated heating capacities (the real heating capacity considering the defrost cycles too), multiply the kWt value in the heating performance tables by the following coefficient.  
 DB = dry bulb  
 WB = wet bulb  
 In case of below zero air ambient temperature with a long period of heat pump operating mode it is necessary to help the evacuation of the water produced during the defrost cycle; this to avoid the formation of ice in the unit basement. Pay attention that the evacuation will not create inconveniences to things or persons.

## HIGH CUSTOMIZATION OF UNIT

The unit can be completed and personalized with a series of dedicated accessories to meet special system needs. The quantity of outside air for recirculation can be adjusted by the machine logic via the air quality probe, ensuring conditions of well-being in the environment and energy savings by treating only the amount of air that is actually required. For improved air quality, the G4 efficiency air filters can be integrated with pocket filters with efficiency F7 or with high-efficiency H10 electrostatic filters. During the summer, when it is essential to dehumidify, the post-heating coil can be installed, which at no cost places the flow of dehumidified air to the comfort temperature. During the winter, the heating function of the heat pump can be integrated with the hot water coil or with the electric pre-heating elements. Air humidification can be provided by the evaporating humidifier with immersed electrodes or with a wet deck humidifier.

## ACCESSORIES

### FCE - ENTHALPY FREE-COOLING

When external conditions allow it, the unit is capable of automatically activating free-cooling mode, which, by keeping the compressors off and drawing in suitably filtered fresh air, cools the served room. The fresh air flow can be varied based on actual needs. This operating mode is especially useful in spring and autumn or with high ambient loads. It allows substantial reduction of the unit's energy consumption and wear of the compressors by placing air directly into the room. The settings are determined automatically by comparing the temperature and humidity outside and in the served room.

### CHW2 - TWO-ROW HOT WATER COIL

Option recommended for very cold climates since it allows heating of the served room. The battery is equipped with a thermostat for the anti-freeze function. The anti-freeze function is always active, even when the unit is in standby. If necessary, it forces opening of the valve to the maximum allowable value for allow passage of water in the coil and to prevent the formation of ice.

In heat pump mode, the hot water coil may allow both pre-heating of the inlet air to the main coil, as well as integration of the capacity provided by the heat pump. As an alternative, it may intervene in complete substitution of the thermal capacity provided by the compressors. This is possible by setting a turning point, i.e. a temperature limit of the fresh air below which use of the compressors is blocked, and the water coil is used as the sole resource. If the water coil provides pre-heating of the air, the control logic reduces its power to a preset value, which keeps the compressors from working with condensation temperatures that are too high. If instead the water coil is used as the main resource (e.g. because the compressors are not available), the maximum power will be provided.

### HOT WATER COIL PRESSURE DROP: AIR SIDE

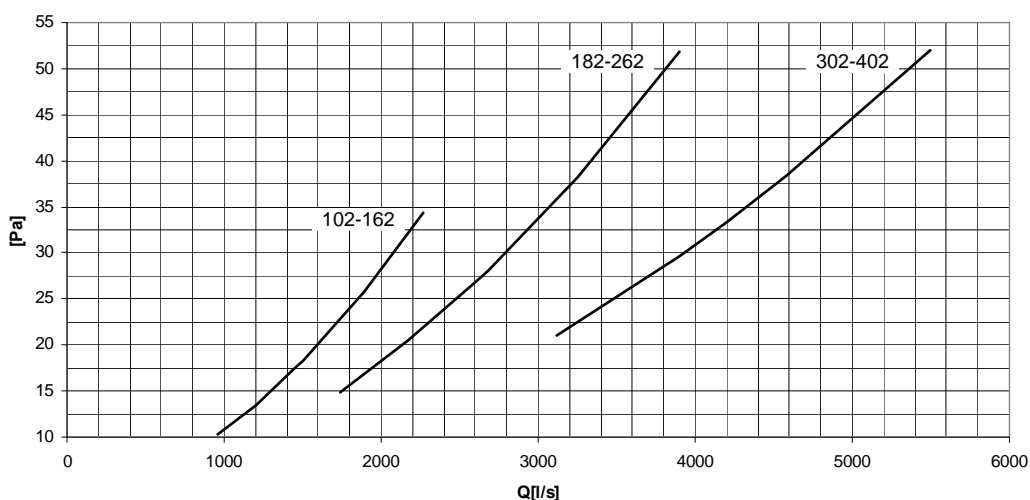

THE AIR SIDE PRESSURE DROPS ARE RELATIVE TO THE MEDIUM AIR TEMPERATURE OF 20°C AND ARE TO BE ADDED TO THE PRESSURE DROPS DUE TO DUCTS, TERMINAL DEVICES AND ANY OTHER COMPONENT THAT CAUSES A DROP IN WORKING DISCHARGE HEAD.  
Q [L/S] = AIR FLOW RATE

E108C001CB01

**HOT WATER COIL PRESSURE DROP: WATER SIDE**

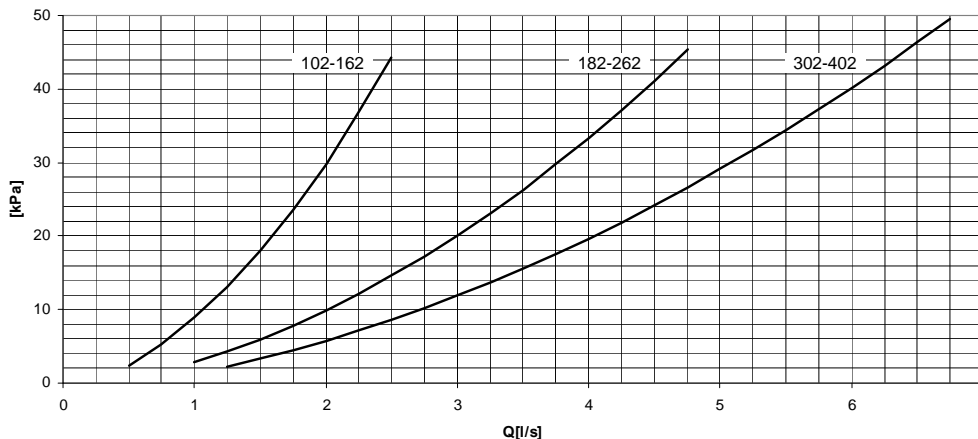

PRESSURE DROPS ON THE WATER SIDE ARE CALCULATED CONSIDERING AN AVERAGE WATER TEMPERATURE OF 65°C  
Q[L/S]= WATER-FLOW RATE



This option reduces the available static pressure (air side).



The component requires connection to the hot water plumbing system (to be provided for by the client).

**PERFORMANCES OF HOT WATER COIL (2 ROWS)**

Size	Ti/To (°C)				
	80,0 / 65,0	70,0 / 55,0	70,0 / 60,0	60,0 / 40,0	
102	1200				
	Qo (l/s)				
	0	68,6	58,6	61,6	45,3
	5	63,3	53,4	56,4	40,2
	10	58,2	48,3	51,3	35,2
	15	53,0	43,3	46,2	30,1
122	1500				
	Qo (l/s)				
	0	80,2	68,5	72,1	52,8
	5	74,0	62,5	66,1	46,8
	10	68,0	56,5	60,1	40,9
	15	62,0	50,6	54,2	35,0
162	1890				
	Qo (l/s)				
	0	93,8	80,1	84,5	61,5
	5	86,6	73,0	77,4	54,5
	10	79,6	66,0	70,4	47,6
	15	72,6	59,1	63,5	40,7
182	2170				
	Qo (l/s)				
	0	112,3	95,8	101,3	73,1
	5	103,7	87,2	92,7	64,7
	10	95,2	78,8	84,3	56,4
	15	86,8	70,5	75,9	48,1
222	2680				
	Qo (l/s)				
	0	129,5	110,2	116,9	83,9
	5	119,6	100,6	107,0	74,3
	10	109,7	90,8	97,3	64,6
	15	100,1	81,2	87,6	55,1
262	3250				
	Qo (l/s)				
	0	147,0	125,2	132,8	94,9
	5	135,7	113,9	121,6	83,8
	10	124,7	102,9	110,5	73,0
	15	113,5	92,1	99,6	62,1
302	3900				
	Qo (l/s)				
	0	187,8	160,0	169,5	121,9
	5	173,4	145,8	155,2	107,8
	10	159,2	131,8	141,1	93,9
	15	145,2	117,9	127,1	80,1
362	4200				
	Qo (l/s)				
	0	197,1	168,0	178,0	127,8
	5	182,1	153,0	163,1	113,0
	10	167,2	138,3	148,2	98,5
	15	152,4	123,8	133,6	83,9
402	4580				
	Qo (l/s)				
	0	208,7	177,7	188,4	135,0
	5	192,7	161,9	172,6	119,4
	10	177,0	146,3	156,9	103,9
	15	161,4	130,9	141,4	88,5

Ta = air temperature entering the air handling coil (°C)  
Ti/To = water temperature inlet/outlet (°C)  
Qo = air flow (l/s)  
kWt = Heating capacity (kW)

**3WVM - MODULATING 3-WAY VALVE**

To be used in conjunction with the hot water coil (optional). It is controlled by the on-board microprocessor by means of a 0-10V signal and allows fully automatic adjustment of the hot water coil. The valve with modulating actuator is provided already installed and wired on the machine.

**PRESSURE DROP MODULATING THREE-WAY VALVE**

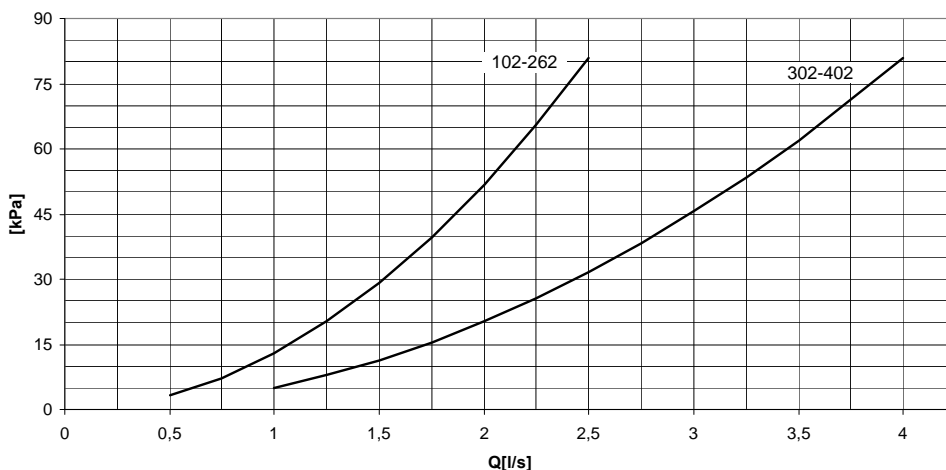

BT08C001CE-01

**EH - ELECTRIC HEATERS.**

This option is advisable for cold climates. Available in various powers, it allows heating of the served room. The electrical heating elements are managed by a thermal control device with two power settings.

The fins are made of aluminium, with a size suitable to ensure high efficiency and maintain low power density on the surfaces to limit overheating. The low temperature of the heating elements increases their lifespan and limits the effect of air ionization.

In heat pump mode, the heating elements may be automatically activated to preheat the inlet air to the main coil, for example during operation with high percentages of fresh air. This extends the operating limits of the machine. The electrical heating elements can be used to boost the yield of the heat pump. The thermal control device is capable of simultaneously activating the pre-heating and integration functions. Also, the electrical heating elements can be used to reduce the time required for defrosting.



Size	102	122	162	182	222	262	302	362	402
6 kW	✓	✓	✓	✗	✗	✗	✗	✗	✗
9 kW	✓	✓	✓	✗	✗	✗	✗	✗	✗
12 kW	✓	✓	✓	✓	✓	✓	✗	✗	✗
18 kW	✗	✗	✗	✓	✓	✓	✓	✓	✓
24kW	✗	✗	✗	✓	✓	✓	✓	✓	✓
36kW	✗	✗	✗	✗	✗	✗	✓	✓	✓

⚠ This operation involves variation of the main electrical data of the machine.

⚠ hot water coil and electric heaters cannot be mounted at the same time

THE LIMITS ARE INDICATIVE AND HAVE BEEN CALCULATED CONSIDERING:  
 - VALUES GENERAL AND NOT SPECIFICATIONS,  
 - STANDARD AIR FLOW-RATE,  
 - NON-CRITICAL POSITIONING AND CORRECT USE OF THE UNIT,  
 - OPERATION AT FULL LOAD

WITH UNIT OPERATING IN INTAKE OF OUTSIDE AIR CALCULATE THE TEMPERATURES OF MIXES WHICH ARE GENERATED FROM THE EXCHANGERS' INLET TO KNOW THE LIMITS.

TO = TEMPERATURE OF AIR ENTERING THE INTERNAL EXCHANGER D.B.(°C)

DB = DRY BULB

TA = EXTERNAL EXCHANGER INLET AIR TEMPERATURE W.B. (°C)

WB = WET BULB

(1) THE DASHED AREA REFERS TO THE FIELD OF UNITS OPERATION STANDARD

(2) EXTENSION OF THE FIELD OF OPERATION WITH PREHEATING HEATING ELEMENTS. TO OBTAIN THE LOWER LIMIT CURVE, CONSIDER AS THE TEMPERATURE DIFFERENCE (DELTA T) THE VALUE SHOWN IN THE TABLE "EXTENSION OF OPERATING LIMITS WITH PRE-HEATING ELEMENTS".

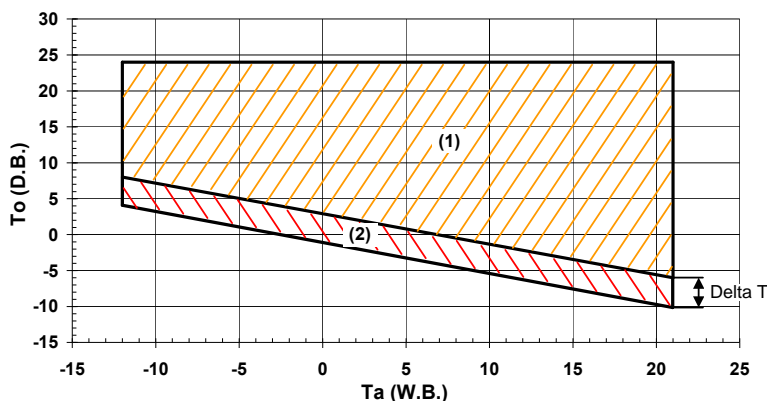

**EXTENSION OF OPERATING LIMITS WITH PRE-HEATING ELEMENTS**

Size	Air flow rate [l/s]		6 kW	9 kW	12 kW	18 kW	24 kW	36 kW
102	1200	Temperature differential / (Delta T) of the air that passes through the electrical heating elements [°C]	4.1	6.2	8.2	-	-	-
122	1500		3.3	4.9	6.6	-	-	-
162	1890		2.6	3.9	5.2	-	-	-
182	2170		-	-	4.6	6.8	9.1	-
222	2680		-	-	3.7	5.5	7.4	-
262	3250		-	-	3.0	4.6	6.1	-
302	3900		-	-	-	3.8	5.1	7.6
362	4200		-	-	-	3.5	4.7	7.1
402	4580		-	-	-	3.2	4.3	6.5

The pre-heating elements make it possible to increase the temperature of the air mixture entering treatment (temperature To) and make it possible to work with lower temperature limits of the mixture entering the internal heat exchanger, extending the operating range of the machine in winter operation. The table of extension of limits of operation shows the temperature differences (Delta T) to be subtracted from the lower limits of the temperature of the air entering the internal heat exchanger (To) in order to obtain the new limit of operation.

E108C001CB01

**AIR FILTERING**

This is an essential function for proper maintenance of conditions of well-being and hygiene in the served rooms. For this reason it is the subject of precise standards based on the specific applications. The units are standard equipped with filters with an efficiency of G4 on the treatment section. They have an ample surface and low pressure drops. The second filtering stage is available through innovative, high-efficiency filters, electro-static, automatically controlled, class H10. Thanks to the minimum pressure drops and the possibility to wash them, they substantially reduce consumption and hence ventilation costs, while at the same time ensuring excellent performance. As an alternative the more traditional high-efficiency F7 rigid pocket filters are available.

**F7 - HIGH EFFICIENCY F7 AIR FILTER**

The multi-dihedral filters with rigid pockets, class F7, are filtering components that are in addition to the standard G4 filters, for more effective filtering. They are widely used in civil air conditioning systems and in industrial applications that require suitable performance concerning fine dusts and particles with dimensions greater than  $\mu\text{m}$ . Class F7 filters are made of fibreglass paper, pleated with constant calibrated spacing, mounted on frames with a sturdy structure in extruded moulded polyester; the ample filtering surface reduces air side pressure drops. Class F7 filters must be replaced after reaching their limits of dirtiness with scheduled periodic maintenance. It is possible to provide as an accessory the dirty filters differential switch, which informs the user that the admissible limit of dirtiness has been reached so as not to excessively reduce the air flow rate with respect to the nominal value.



 This option reduces the available static pressure (air side).

**FES - AIR FILTER, ELECTRO-STATIC, HIGH-EFFICIENCY, H10**

Class H10 high-efficiency filters are additional filtering components with an active electrostatic system. Solid or liquid particles contained in the air flow are trapped by and electrical field. The air flow through the filter is affected in two main phases: release of an electrical charge to the particles (ionization), and capture of the particles by electrostatic deposit (captive). On a periodic basis, the filters must be washed to remove the captured particles.

The filters are capable of trapping fine dusts, some types of viruses and micro-organisms (anti-bacterial action) with very modest pressure drops. The range of use normally includes fine powders that measure less than  $1 \mu\text{m}$ .

Typical pollutants are cigarette smoke ( $0.5 \div 0.3 \mu\text{m}$ ), oily vapours ( $1 \div 0.2 \mu\text{m}$ ), PM10 (particles  $< 10 \mu\text{m}$ ), PM2.5 (particles  $< 2.5 \mu\text{m}$ ), PM1 (particles  $< 1 \mu\text{m}$ ), etc.

Dirtiness of the electric filter is signalled by a sensor that makes it possible to schedule periodic maintenance, which can be easily performed by washing in water with a special non-aggressive detergent for aluminium.

The greater initial cost, as compared to a traditional pocket filter, is recovered quickly since the electrostatic filters last for the entire life of the machine, whereas pocket filters require periodic replacement.

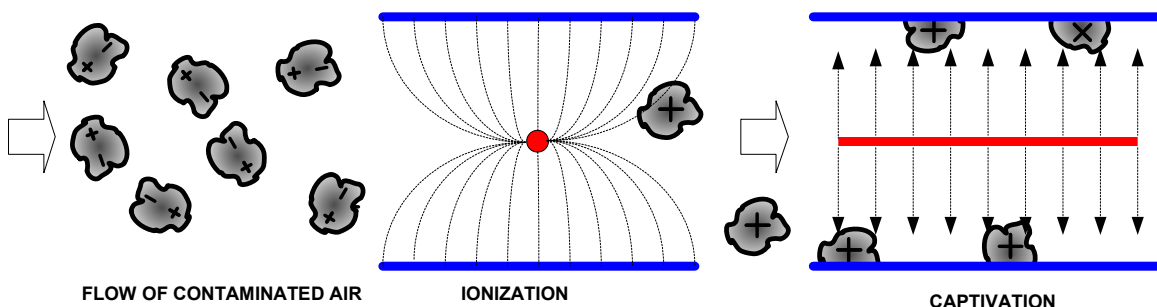

 This option reduces the available static pressure (air side).

 This operation involves variation of the main electrical data of the machine.

BT08C001CE-01

### COMPARISON OF OPERATING COSTS: A CASE STUDY

The high-efficiency electrostatic filters allow very rapid return of the initial investment as compared with a traditional filtering system, thanks to the reduction of electrical consumption of the ventilation sections and the greatly reduced maintenance costs, since the filters do not require periodic replacement. A typical case study shows how return on investment occurs in just a few months. In the heavy-duty use of a shopping centre, this occurs by the second year with respect to a traditional system with pocket, F7, high-efficiency second stage filtering. This also greatly reduces environmental impact, both due to more rational use of energy, and because no special waste is produced, such as the used traditional pocket filters.

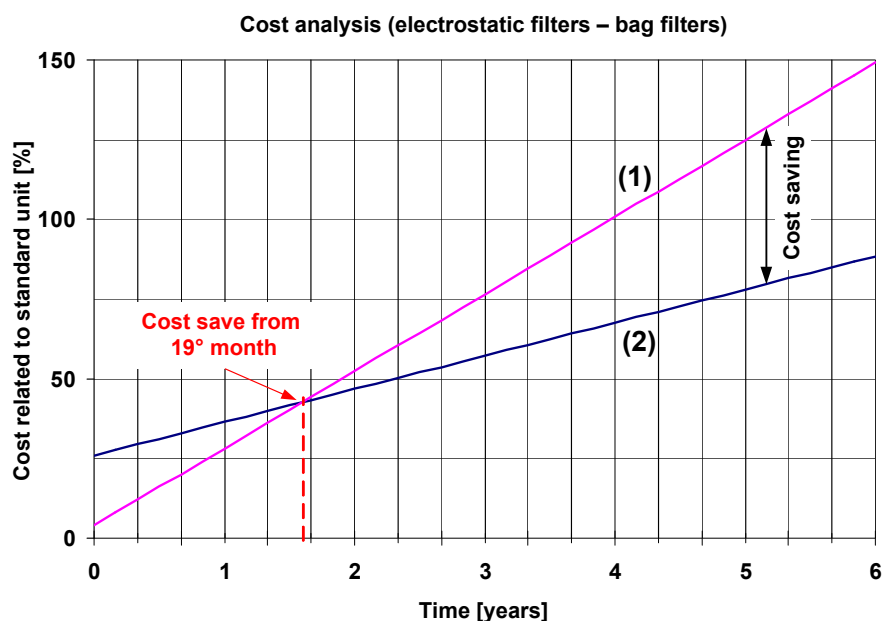

(1) COST FOR PURCHASE AND OPERATION OF THE SECOND FILTERING STAGE, TRADITIONAL TYPE, WITH POCKETS, EFFICIENCY F7

(2) COST FOR PURCHASE AND OPERATION OF THE SECOND FILTERING STAGE, ELECTROSTATIC TYPE, WITH POCKETS, EFFICIENCY H10

IN ORDER, THE PERCENTAGE OF COST INCREASES ARE PRESENTED FOR A STANDARD UNIT WITH SINGLE FILTERING STAGE OF G4

EFFICIENCY. OPERATION INCLUDES GREATER COSTS FOR VENTILATION AND MAINTENANCE. PERFORMANCE OF ELECTROSTATIC FILTER:  
 - -25% ON VENTILATION COSTS  
 - -90% ON COSTS OF MAINTENANCE

EXAMPLE BASED ON MEDIUM SIZED UNITS USED ON A SHOPPING CENTRE THAT IS OPEN 12 HOURS A DAY, 6 DAYS A WEEK, AND SUBJECT TO ROUTINE MAINTENANCE 3 TIMES A YEAR

The values are to be considered approximate.

 The H10 class electrostatic filters and the F7 pocket filters cannot be included simultaneously on the machine.

### PSAF - DIFFERENTIAL PRESSURE SWITCH FOR DIRTY AIR FILTERS

It makes it possible to detect and signal (with a suitable alarm) when the dirtiness of the air filter reaches its maximum level. This provides the machine operator with information on when filter maintenance is required. The detection signal is installed in the unit. It is already connected to the electrical panel and pre-calibrated in the factory. Calibration can be modified by a specialized service centre during the commissioning phase.



E108C001CB01

**CPHG - HOT GAS RE-HEATING COIL**

This option is recommended during the summer when dehumidification of the room is required. The flow of air to enter the room may contain a higher level of humidity than desired. The dehumidification process is used to reduce it. The air flow is first cooled in the treatment coil with separation of condensation. It is then freely post-heated to maintain the desired condition of comfort in the room served. The post-heating coil is located behind the treatment coil and is activated by drawing a flow of hot gas down the line from the compressors through the action of a dedicated solenoid valve. The process starts working based on the humidity set-point established by the user. With respect to traditional devices, such as electrical heating elements or hot water coils, the use of the post-heating coil does not consume any energy. It also lowers the condensation temperature, which provides two positive effects: the power absorbed by the compressors is considerably reduced, and at the same time the cooling power is increased with greater EER.

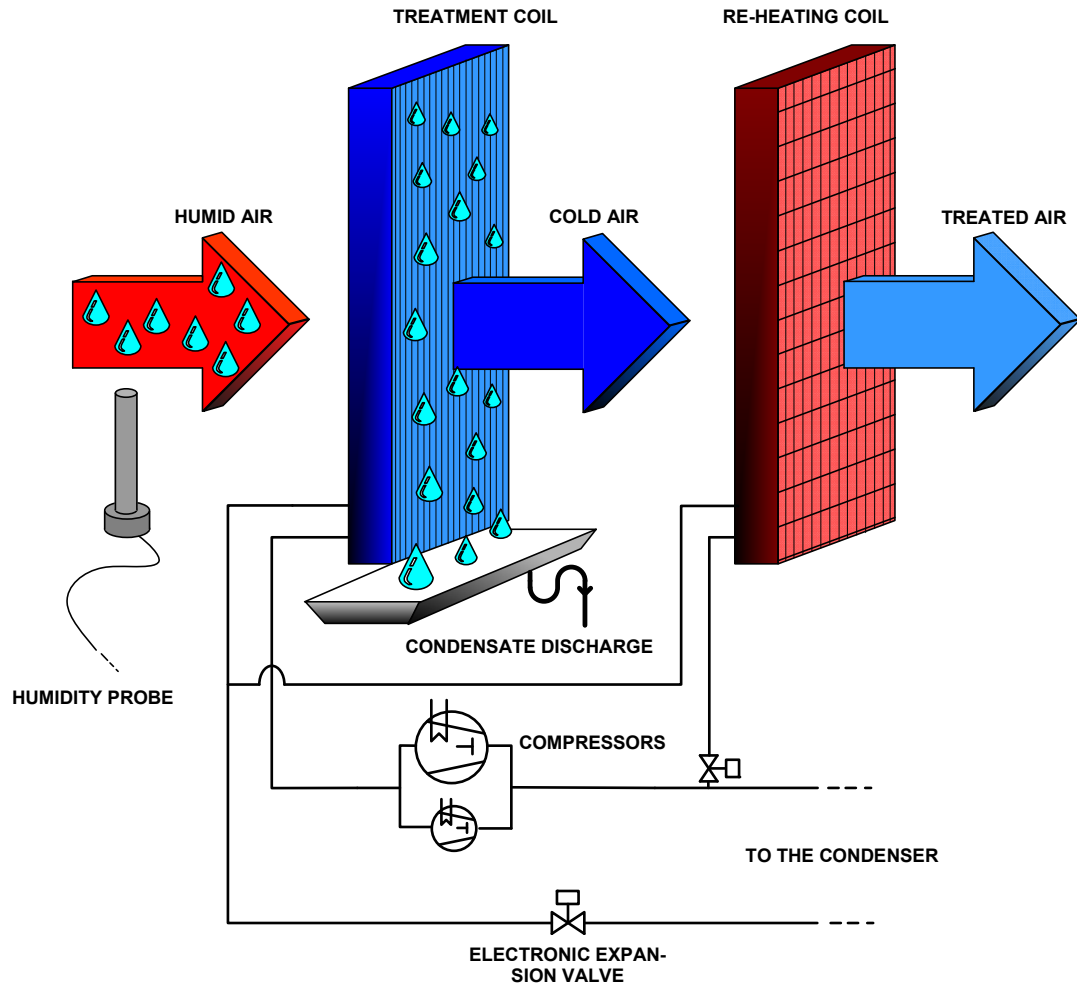

 This option reduces the available static pressure (air side).

BT08C001CE-01

**PERFORMANCE HOT GAS RE-HEATING COIL**

Size		outdoor air temperature °C					
		25 kWt	27 kWt	30 kWt	32 kWt	35 kWt	
102	Qo (l / s)	1200					
	Ta (°C)	10	11,1	12,0	13,2	14,1	15,4
		12	10,3	11,1	12,4	13,2	14,5
		14	9,4	10,3	11,5	12,4	13,6
		16	8,6	9,4	10,7	11,5	12,8
		18	7,8	8,6	9,8	10,7	11,9
20	7,0	7,8	9,0	9,8	11,1		
122	Qo (l / s)	1500					
	Ta (°C)	10	12,8	13,8	15,2	16,2	17,7
		12	11,8	12,8	14,2	15,2	16,7
		14	10,9	11,8	13,3	14,2	15,7
		16	9,9	10,9	12,3	13,3	14,7
		18	8,9	9,9	11,3	12,3	13,8
20	8,0	8,9	10,4	11,3	12,8		
162	Qo (l / s)	1890					
	Ta (°C)	10	14,7	15,9	17,6	18,7	20,4
		12	13,6	14,7	16,4	17,6	19,3
		14	12,5	13,6	15,3	16,4	18,1
		16	11,4	12,5	14,2	15,3	17,0
		18	10,3	11,4	13,0	14,2	15,9
20	9,2	10,3	11,9	13,0	14,7		
182	Qo (l / s)	2170					
	Ta (°C)	10	18,2	19,6	21,6	23,0	25,1
		12	16,8	18,2	20,2	21,6	23,7
		14	15,5	16,8	18,8	20,2	22,3
		16	14,1	15,5	17,5	18,9	20,9
		18	12,7	14,1	16,1	17,5	19,6
20	11,4	12,8	14,8	16,1	18,2		
222	Qo (l / s)	2680					
	Ta (°C)	10	20,7	22,2	24,6	26,2	28,6
		12	19,1	20,7	23,0	24,6	27,0
		14	17,6	19,1	21,4	23,0	25,4
		16	16,0	17,6	19,9	21,4	23,8
		18	14,5	16,0	18,3	19,9	22,2
20	13,0	14,5	16,8	18,3	20,7		
262	Qo (l / s)	3250					
	Ta (°C)	10	23,2	24,9	27,6	29,4	32,1
		12	21,4	23,2	25,8	27,6	30,3
		14	19,7	21,4	24,0	25,8	28,5
		16	17,9	19,7	22,3	24,0	26,7
		18	16,2	18,0	20,5	22,3	24,9
20	14,5	16,2	18,8	20,5	23,2		
302	Qo (l / s)	3900					
	Ta (°C)	10	30,3	32,6	36,0	38,4	41,9
		12	28,0	30,3	33,7	36,1	39,6
		14	25,7	28,0	31,4	33,8	37,2
		16	23,5	25,8	29,1	31,5	34,9
		18	21,3	23,5	26,9	29,2	32,6
20	19,0	21,3	24,6	26,9	30,3		
362	Qo (l / s)	4200					
	Ta (°C)	10	31,7	34,1	37,7	40,1	43,8
		12	29,3	31,7	35,3	37,7	41,4
		14	26,9	29,3	32,9	35,3	38,9
		16	24,6	26,9	30,5	32,9	36,5
		18	22,2	24,6	28,1	30,5	34,1
20	19,9	22,2	25,7	28,1	31,7		
402	Qo (l / s)	4580					
	Ta (°C)	10	33,3	35,9	39,6	42,2	46,1
		12	30,8	33,3	37,1	39,7	43,5
		14	28,3	30,8	34,6	37,1	41,0
		16	25,8	28,3	32,1	34,6	38,4
		18	23,4	25,8	29,6	32,1	35,9
20	20,9	23,4	27,1	29,6	33,4		

Ta = outlet air temperature from the treatment coil and entering the post-heating coil

Qo = air flow rate (l/s)

kWt = thermal power provided (kW)

The post-heating coil is supplied with hot gas released between the supply of the compressor and the condensation coil. Since the temperature of the hot condensation gas is related to the outside air temperature, the approximate powers of the post-heating coil are expressed based on the outside air temperature.

E108C001CB01

**HSE - STEAM HUMIDIFIER WITH IMMERGED ELECTRODES**

This device is perfect for the winter period when it is necessary to add humidity to the room without cooling the air flow. The modulating automatic adjustment makes it possible to adapt the production of steam and the related operating costs to meet actual needs. Available in different powers, the device is suitable for use with unsoftened water of medium conductivity. It is complete with water filling solenoid valve, disposable cylinder, water drainage solenoid valve, distribution nozzle, electronic control card with functions of verification of water level, verification of conductivity, anti-foam, manual override of water drainage. To ensure the utmost hygiene, the cylinder is automatically drained after a certain period of inactivity. The device includes an automatically activated anti-freeze device. A supply probe is used to monitor the humidity level. It is installed and wired on-board the machine.

The accessory is installed inside the unit and is connected to the electrical panel of the machine.



**COMBINATIONS ELECTRODE BOILER STEAM HUMIDIFIER**

Size	102	122	162	182	222	262	302	362	402
3 kg/h	✓	✓	✓	✗	✗	✗	✗	✗	✗
5 kg/h	✓	✓	✓	✓	✓	✓	✗	✗	✗
8 kg/h	✓	✓	✓	✓	✓	✓	✓	✓	✓
15 kg/h	✗	✗	✗	✓	✓	✓	✓	✓	✓

⚠ This operation involves variation of the main electrical data of the machine.

⚠ This accessory requires the presence of a water circuit and drain on board the machine. Provided by the customer

**(HWS -)WATER TO WASTE EVAPORATING WET-DECK HUMIDIFIER**

This option is recommended when quick, efficient humidification of the served room is required. Humidification of the air mixture occurs by passing the air flow through a honeycomb package that is kept humid at all times by a series of nozzles that inject water in small drops. The reserve of water for treatment is taken directly from the water mains. During operation, the pure water vapour is mixed with the air currents. The remaining part, enriched with mineral salts, is collected in the tub and eliminated. The constant exchange of water ensures cleaning of the evaporation septum and provides maximum limitation of the formation and proliferation of Legionnaire's Disease. With this option, energy consumption for water evaporation is limited. Whenever the packaged humidifier is active, in addition to humidifying, adiabatic cooling of the air takes place, which is constantly compensated for by the thermal control device. Direct connection to the plumbing system eliminates the need for special water treatment and easy control of the humidification process by means of the measuring and adjusting device of the water flow rate provided standard.

The accessory is installed inside the unit and is connected to the electrical panel of the machine.

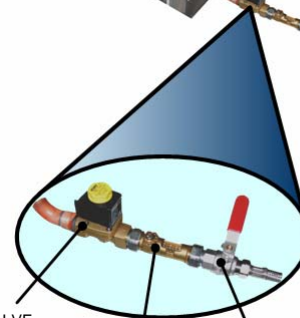

SOLENOID VALVE  
MEASURING DEVICE ADJUSTER  
MANUAL SHUT-OFF VALVE

⊗ This option reduces the available static pressure (air side).

⚠ This accessory requires the presence of a water circuit and drain on board the machine. Provided by the customer

Size		102	122	162	182	222	262	302	362	402
T <sub>a</sub> (°C) D.B.	T <sub>a</sub> (°C) W.B.	kg/h	kg/h	kg/h	kg/h	kg/h	kg/h	kg/h	kg/h	kg/h
30	15,1	25	31	39	45	56	67	81	87	95
35	17,6	31	39	49	56	69	84	101	109	119
40	19,8	38	47	60	68	85	102	123	132	144

T<sub>a</sub> D.B.= dry bulb temperature of inlet air to the wet deck.

T<sub>a</sub> W.B.= wet bulb temperature of inlet air to the wet deck.

Approximate values of the maximum rate of steam released by the wet deck humidifier to the air to obtain controlled thermal and humidity conditions in supply.

The data refer to a unit with standard air flow rate in supply.

BT08C001CE-01

**PAQC - AIR QUALITY SENSOR FOR CO2 P.P.M. CONTROL**

This option is recommended for areas with highly variable rates of traffic. The probe measure the amount of CO2 in the environment and sends the machine a 0/10V proportional signal. Based on the received signal, the machine manages the input of the correct amount of refresh air, preventing wasted energy and money due to a treatment of fresh air in excess of actual needs. The probe is installed and wired on board the machine and is located in the unit's supply duct.



**PAQCV - AIR QUALITY SENSOR FOR CO2 AND VOC P.P.M. CONTROL**

The option is recommended in areas with tobacco smoke, formaldehyde (from solvents, deodorants, glues, paints, detergents), food preparation, etc. The probe measure the amount of CO2 and VOC (volatile organic compounds) in the environment and sends the machine a 0/10V proportional signal. Based on the received signal, the machine manages the input of the correct amount of refresh air, preventing wasted energy and money due to a treatment of fresh air in excess of actual needs. The probe is installed and wired on board the machine and is located in the unit's supply duct.



**MHP - HIGH AND LOW PRESSURE GAUGES**

It allows measurement of the pressure of the refrigerant at the supply and return of the compressors, making these parameters easier to check by technicians assigned to operate the machine. The two liquid pressure gauges and corresponding pressure sockets are installed on the machine in an easily accessible location.



**CREFB - DEVICE FOR REDUCTION OF FAN CONSUMPTION ECOBREEZE**

This option is recommended for substantial reduction in the consumption of electrical energy for ventilation and to limit noise emissions in the external section of the machine. The Eco-Breeze logic makes it possible to run the external axial fans with variable rotation speed based on the condensation pressure. When fresh air temperature is low, a minimum air flow rate is required to hold down the condensation pressure. Therefore, at low fresh air temperatures, fan rotation speed is reduced, resulting in reduced electricity consumption and noise emission (summer operation).

In operation in heat pump mode with low outside temperature, ventilation is reduced to the external coil so as not to exceed the evaporation pressure limits for correct operation of the unit, with the added benefit of reduced electrical consumption and noise.

The Eco-Breeze option uses special fans driven by brushless electric motors with complete electronic control and very high efficiency.

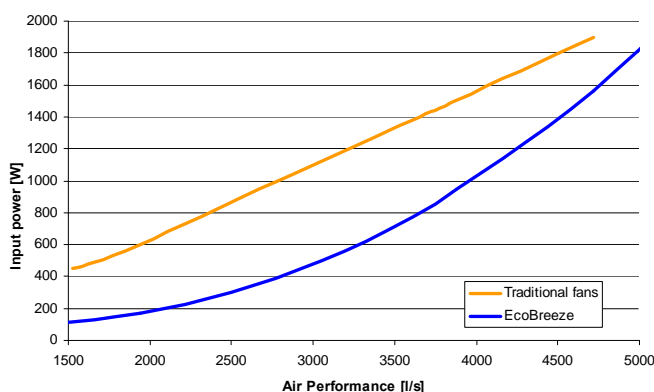
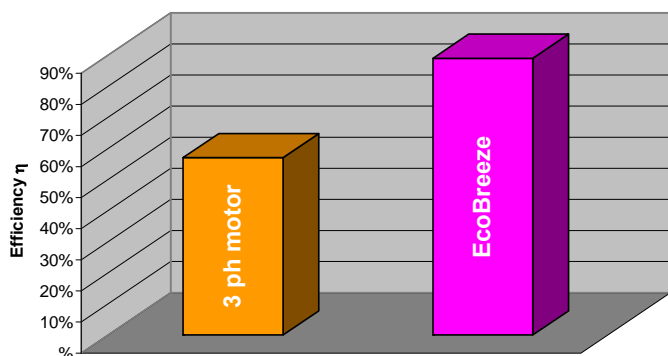
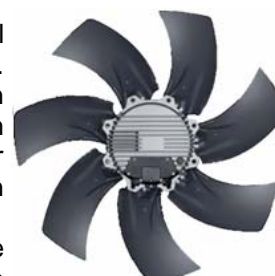

E108C001CB01

**SI - INTAKE SILENCERS**

This option is recommended in applications where noise needs to be kept to a minimum. Perfect in systems with very short return ducts because they reduce the noise transmitted to the environment. They are special sound-absorbent septums especially studied for this function. They are located in the return section and made of quality materials.

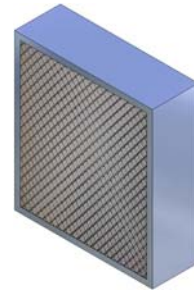

**AMRX - RUBBER ANTIVIBRATION MOUNTS**

The rubber anti-vibration devices are fastened in housings on the longitudinal members. They reduce the vibrations caused by the machine, reducing the noises transmitted by the support structures. These elastic bodies soften axial and tangential stresses. Their mechanical and physical characteristics remain nearly unchanged over time thanks to the highly resistant material they are made of. As an alternative to the rubber anti-vibration devices, it is possible to use neoprene rubberized strips on the longitudinal support members.

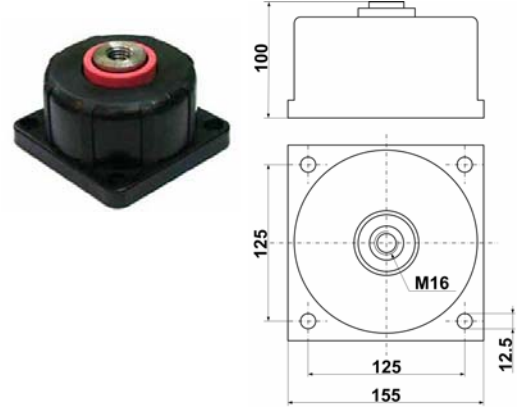

 separately supplied accessories

**(ESM - SMOKE DETECTOR**

This option allows detection of smoke in the room by analyzing the return air. The Tyndal-effect increased sensitivity smoke detector is perfect for ventilation ducts since it is capable of detecting rarefied smoke in high-speed air flows. Smoke detection occurs using a photo-optical system with a labyrinth chamber. The alarm signal is processed by an on-board micro-processor which verifies the condition and sends a message to the machine controller such as smoke alarm, failure, or service required. The device is composed of a Venturi tube, installed inside the return duct, and a control unit with a sensor that is located on the outside duct. Assembly and wiring are done at the factory.



**CONTROL LOGICS IN THE EVENT OF ALARM SIGNAL**

Machine logics	Description	CSNX-XHE
Complete shutdown	Supply fan	Off
	Exhaust fan	Off
	Fresh air Shutter	Closed
	Discharge damper	Closed
Room kept de-pressurized	Supply fan	Off
	Exhaust fan	On
	Fresh air Shutter	Closed
	Discharge damper	Open
Room kept pressurized	Supply fan	On
	Exhaust fan	Off
	Fresh air Shutter	Open
	Discharge damper	Closed

The machine logic manages the signal from the smoke detector installed in the return section or by a fire detection unit, implementing one of the actions shown in the table which can be set as a parameter. If there is an alarm signal and according to the set logic, the compressors are always shut off. The roof-top units may not be used as smoke extractors.

BT08C001CE-01

**PM - PHASE MONITOR**

The phase monitor makes it possible to check the correct connection of the phases and their imbalance in units powered with a tri-phase system. If the connection of the phases is not correct, or the limit is exceeded for imbalance between phases, the monitor acts on the control circuit, which orders shutdown of the machine. The device is installed and wired on board the machine.

**PFCP - POWER FACTOR CORRECTION CAPACITORS (COSFI > 0.9)**

The component is necessary to lower the phase difference between current and voltage in the electromagnetic components of the machine, such as asynchronous motors. By re-phasing it is possible to reduce the intensity of the line current by reducing a part of the power of the mains (reactive power). This leads to an economic benefit which the energy provider grants to the final user. The component makes it possible to bring the cosfi power factor to values which on average are greater than 0.9.

The device is installed and wired on board the machine.



**MOB - SERIAL PORT RS485 WITH MODBUS PROTOCOL**

It allows serial connection of supervision systems, using ModBus as the communication protocol. It allows access to the complete list of operating variables, controls and alarms.

The device is installed and wired on board the machine.



**LON - SERIAL PORT RS485 WITH LONWORK PROTOCOL**

It allows serial connection of supervision systems, using LonWork as the communication protocol. It allows access to a list of operating variables, control and alarms compliant with the Echelon standard.

The device is installed and wired on board the machine.



**RCMRX - REMOTE CONTROL WITH REMOTE MICROPROCESSOR CONTROL**

Device which allows complete control of the machine from a remote location. It is easily wall-mounted, and has the same appearance and functions as the user interface on board the unit (user-friendly software).

To be connected during commissioning of the machine at a maximum distance of 100 m.



 separately supplied accessories

E108C001CB01

**(CMS -)CLIVET MANAGEMENT SYSTEM (CMS) CLIVET SUPERVISING SYSTEM (CMS)**

Clivet Management System (CMS) is a Clivet supervision system that allow to schedule and manage all the installed Clivet conditioning units, optimizing their functional working and the others systems in order to reduce the energy consumption.

Thanks to the simple use of the software and to the tridimensional graphic interface, it is possible to change complex activities of system operating into simple activities made by the customer.

Clivet management system let to visualize the maintenance state of the conditioning units, valuate and manage the alarms.

The user makes operation on the supervision workstation or on the PLC (Programmable Logic Controller) interface display. The exchange data between workstation, units, control electronic devices, remote managing electronic devices is made on serial bus networks by communication standard protocol RS485, or on local network LAN (Local Area Network) Ethernet TCP/IP.

The control software let to verify the conditioning unit and to make the on-line assistance directly from Clivet factory using the telephone network.

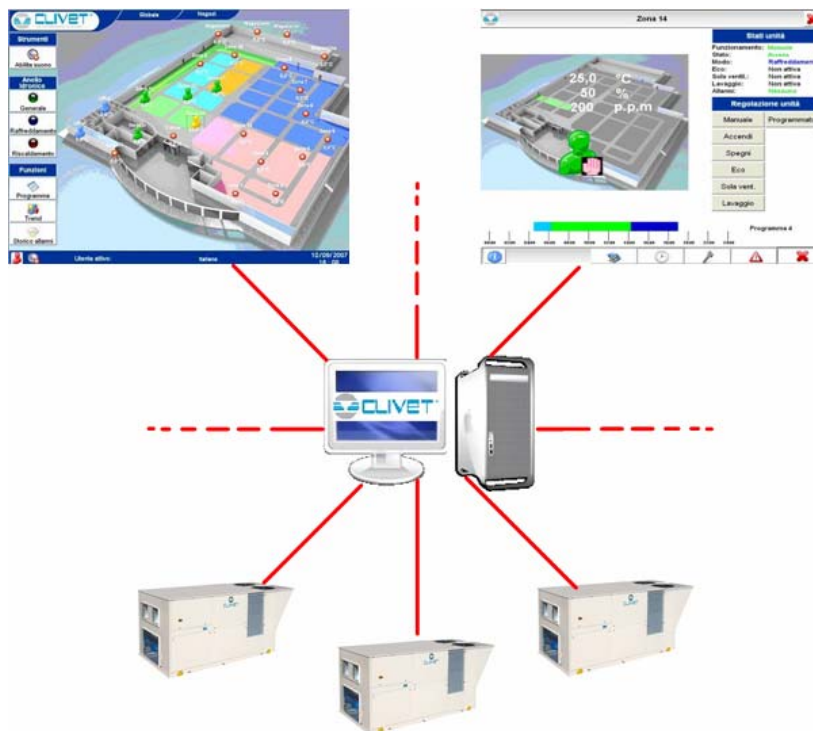

<b>CSNX-XHE OPTIONS</b>		
<b>OPTION</b>	<b>DESCRIPTION</b>	
<b>PCO</b>	Automatic constant flow control device	●
<b>RE1</b>	Active energy recovery of expelled air	●
<b>FC</b>	Thermal free-cooling	●
<b>FCE</b>	Enthalpy free-cooling	○
<b>CREFP</b>	Device for fan consumption reduction of the external section with variable speed (phase-cutting)	●
<b>CREFB</b>	Device for reduction of fan consumption EcoBreeze	○
<b>CHW2</b>	2 rows hot water coil	○
<b>3WVM</b>	Modulating three-way valve	○
<b>EH</b>	Electric heaters	○
<b>AMRX</b>	Rubber antivibration mounts	○
<b>Refrigerant Circuit</b>		
<b>EVE</b>	Electronic expansion valve	●
<b>MHP</b>	High and low pressure gauges	○
<b>CPHG</b>	Hot gas re-heating coil	○
<b>Ducting Circuit</b>		
<b>FPG4</b>	Pleated air filter class G4 (EN779 norm)	●
<b>F7</b>	High efficiency F7 air filter	○
<b>FES</b>	High efficiency H10 electrostatic air filter	○
<b>PSAF</b>	Differential pressure switch for dirty air filters	○
<b>HSE</b>	Electrode boiler steam humidifier	○
<b>HWS</b>	Water to waste evaporating wet-deck humidifier	○
<b>SI</b>	Intake silencers	○
<b>SERMD</b>	Modulating air outlet damper	●
<b>Electric Circuit</b>		
<b>RCMRX</b>	Remote control with remote microprocessor control	○
<b>MOB</b>	Serial port RS485 with MODBUS protocol	○
<b>LON</b>	Serial port RS485 with LONWORK protocol	○
<b>PAQC</b>	Air quality sensor for CO2 p.p.m. control	○
<b>PAQCV</b>	Air quality sensor for CO2 and VOC p.p.m. control	○
<b>DESM</b>	Smoke detector	○
<b>PM</b>	Phase monitor	○
<b>PFCP</b>	Power factor correction capacitors (cosfi > 0.9)	○

● ACCESSORIES STANDARD

○ ACCESSORIES OPTIONAL

E108C001CB01

**FUNCTIONAL CLEARANCES**

When placing the unit, it is necessary to comply with the functional spaces indicated in the dimensions. Compliance with fictional spaces is essential to:

- ensure proper operation of the unit
- allow maintenance technicians easy access to the equipment compartments
- protect authorized operators and exposed persons.

If several units are placed near one another, the functional spaces between machines must be doubled.

**DIMENSIONAL DRAWING**

Size 102 - 122 - 162

DIMENSIONAL DRAWING(1)

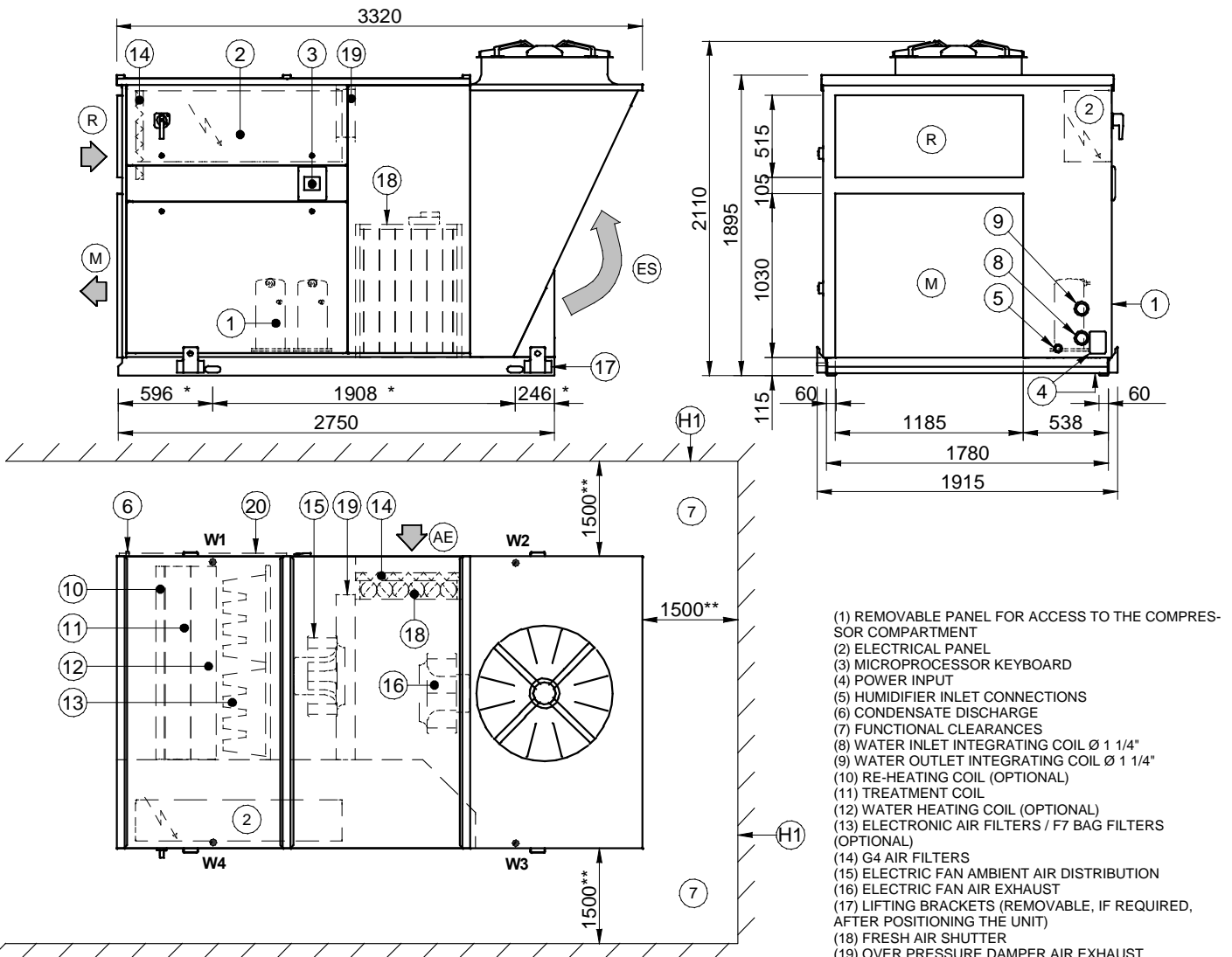

- (1) REMOVABLE PANEL FOR ACCESS TO THE COMPRESSOR COMPARTMENT
- (2) ELECTRICAL PANEL
- (3) MICROPROCESSOR KEYBOARD
- (4) POWER INPUT
- (5) HUMIDIFIER INLET CONNECTIONS
- (6) CONDENSATE DISCHARGE
- (7) FUNCTIONAL CLEARANCES
- (8) WATER INLET INTEGRATING COIL Ø 1 1/4"
- (9) WATER OUTLET INTEGRATING COIL Ø 1 1/4"
- (10) RE-HEATING COIL (OPTIONAL)
- (11) TREATMENT COIL
- (12) WATER HEATING COIL (OPTIONAL)
- (13) ELECTRONIC AIR FILTERS / F7 BAG FILTERS (OPTIONAL)
- (14) G4 AIR FILTERS
- (15) ELECTRIC FAN AMBIENT AIR DISTRIBUTION
- (16) ELECTRIC FAN AIR EXHAUST
- (17) LIFTING BRACKETS (REMOVABLE, IF REQUIRED, AFTER POSITIONING THE UNIT)
- (18) FRESH AIR SHUTTER
- (19) OVER PRESSURE DAMPER AIR EXHAUST
- (20) ACCESS FOR INSPECTION OF COILS, FILTERS, HEATING ELEMENTS
- (R) AMBIENT AIR INTAKE
- (M) AMBIENT AIR DISTRIBUTION
- (AE) FRESH AIR INTAKE
- (ES) AIR EXHAUST
- (H1) WALL WITH SAME HEIGHT AS UNIT ON A MAXIMUM OF THREE SIDES
- (\*) VIBRATION MOUNTS POSITION
- (\*\*) SUGGESTED CLEARANCE

**WEIGHT DISTRIBUTION**

Size		102	122	162
W1	kg	255	257	267
W2	kg	253	253	262
W3	kg	320	323	335
W4	kg	322	327	341
Shipping weight	kg	1150	1160	1205

**DIMENSIONAL DRAWING**

Size 182 - 222 - 262

DIMENSIONAL DRAWING(2)

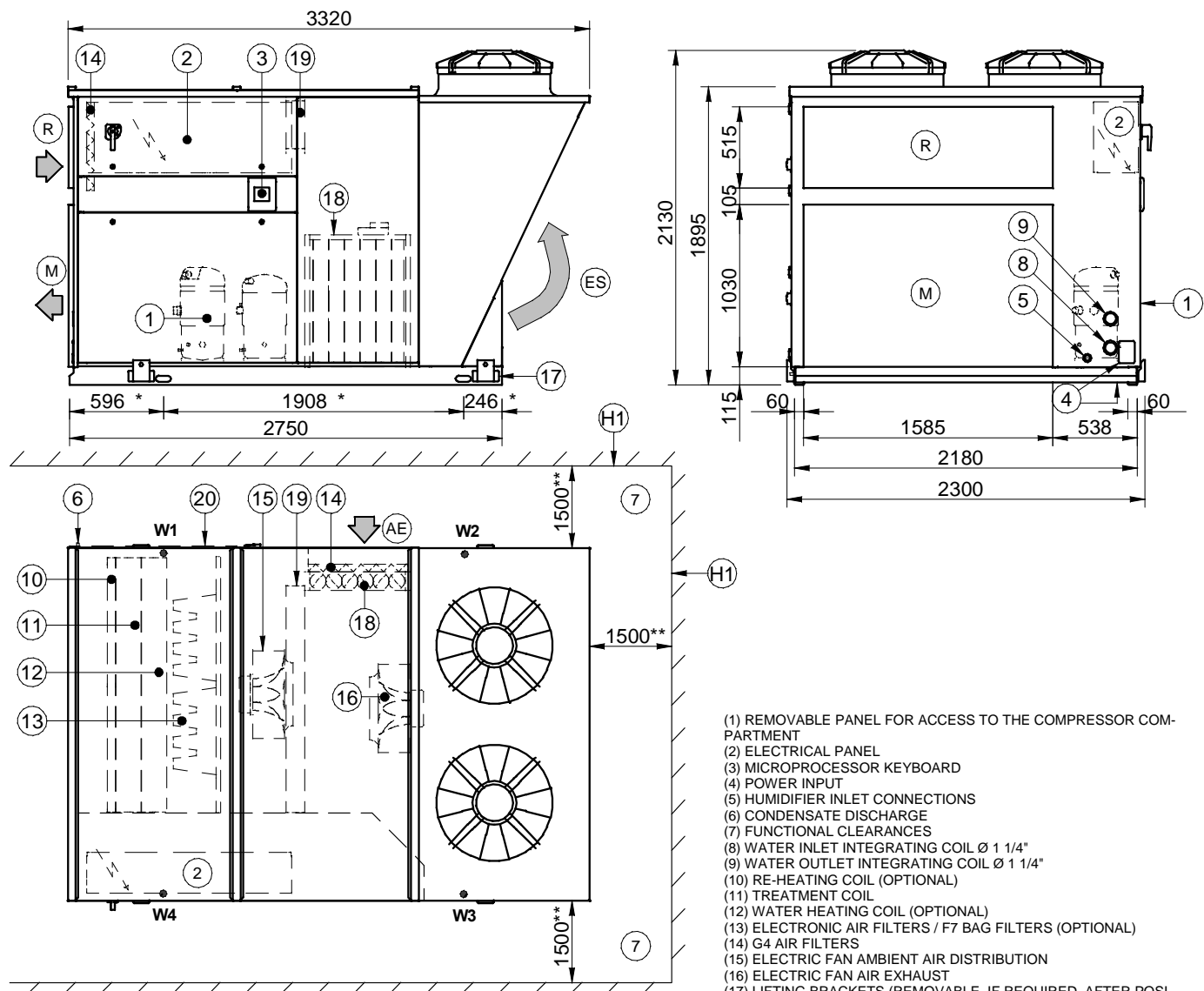

- (1) REMOVABLE PANEL FOR ACCESS TO THE COMPRESSOR COMPARTMENT
- (2) ELECTRICAL PANEL
- (3) MICROPROCESSOR KEYBOARD
- (4) POWER INPUT
- (5) HUMIDIFIER INLET CONNECTIONS
- (6) CONDENSATE DISCHARGE
- (7) FUNCTIONAL CLEARANCES
- (8) WATER INLET INTEGRATING COIL Ø 1 1/4"
- (9) WATER OUTLET INTEGRATING COIL Ø 1 1/4"
- (10) RE-HEATING COIL (OPTIONAL)
- (11) TREATMENT COIL
- (12) WATER HEATING COIL (OPTIONAL)
- (13) ELECTRONIC AIR FILTERS / F7 BAG FILTERS (OPTIONAL)
- (14) G4 AIR FILTERS
- (15) ELECTRIC FAN AMBIENT AIR DISTRIBUTION
- (16) ELECTRIC FAN AIR EXHAUST
- (17) LIFTING BRACKETS (REMOVABLE, IF REQUIRED, AFTER POSITIONING THE UNIT)
- (18) FRESH AIR SHUTTER
- (19) OVER PRESSURE DAMPER AIR EXHAUST
- (20) ACCESS FOR INSPECTION OF COILS, FILTERS, HEATING ELEMENTS
- (R) AMBIENT AIR INTAKE
- (M) AMBIENT AIR DISTRIBUTION
- (AE) FRESH AIR INTAKE
- (ES) AIR EXHAUST
- (H1) WALL WITH SAME HEIGHT AS UNIT ON A MAXIMUM OF THREE SIDES
- (\*) VIBRATION MOUNTS POSITION
- (\*\*) SUGGESTED CLEARANCE

**WEIGHT DISTRIBUTION**

Size		182	222	262
W1	kg	313	323	343
W2	kg	306	319	325
W3	kg	392	410	417
W4	kg	401	416	440
Shipping weight	kg	1412	1468	1525

E108C001CB01

**DIMENSIONAL DRAWING**

Size 302 - 362 - 402

DIMENSIONAL DRAWING(3)

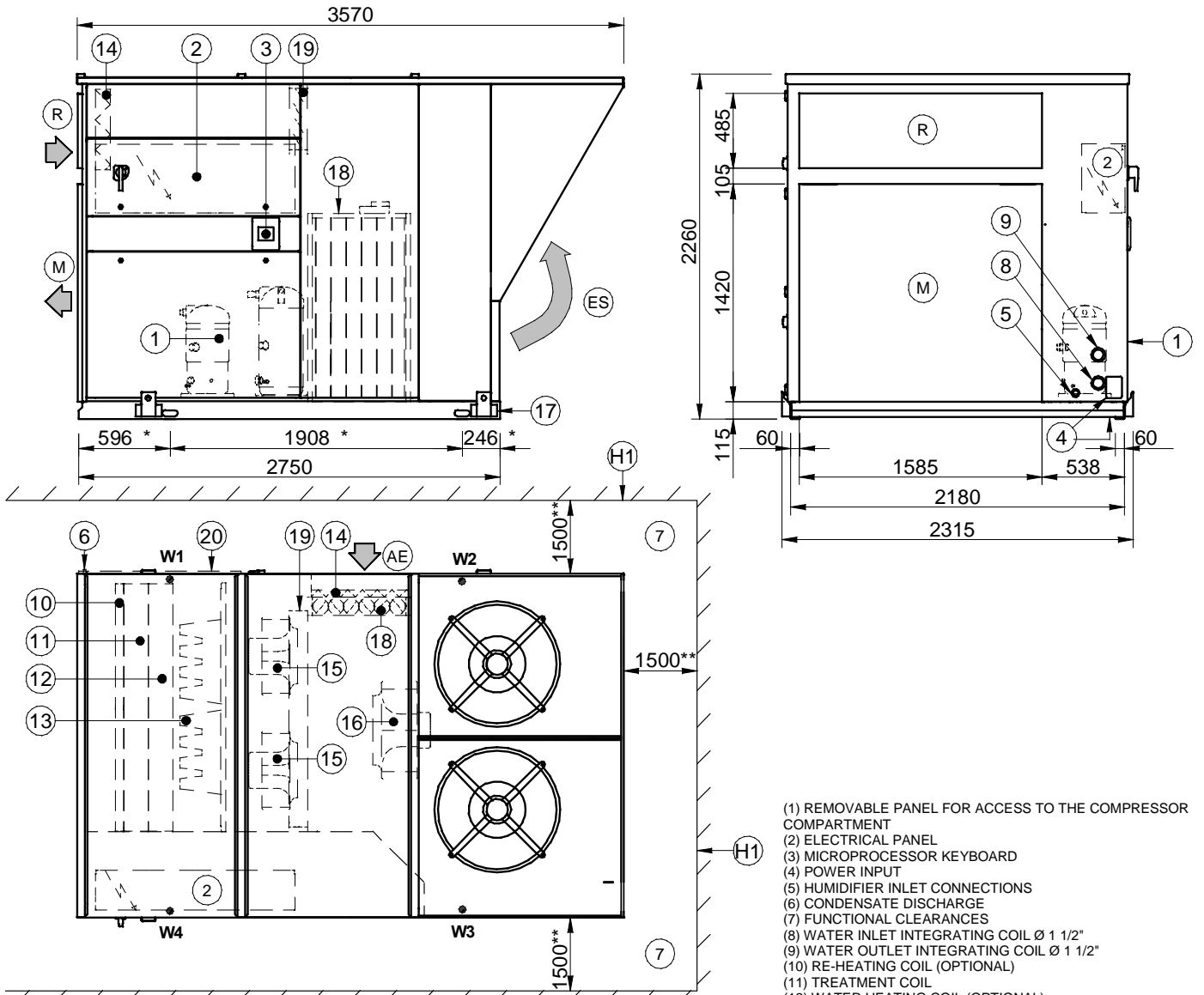

- (1) REMOVABLE PANEL FOR ACCESS TO THE COMPRESSOR COMPARTMENT
- (2) ELECTRICAL PANEL
- (3) MICROPROCESSOR KEYBOARD
- (4) POWER INPUT
- (5) HUMIDIFIER INLET CONNECTIONS
- (6) CONDENSATE DISCHARGE
- (7) FUNCTIONAL CLEARANCES
- (8) WATER INLET INTEGRATING COIL Ø 1 1/2"
- (9) WATER OUTLET INTEGRATING COIL Ø 1 1/2"
- (10) RE-HEATING COIL (OPTIONAL)
- (11) TREATMENT COIL
- (12) WATER HEATING COIL (OPTIONAL)
- (13) ELECTRONIC AIR FILTERS / F7 BAG FILTERS (OPTIONAL)
- (14) G4 AIR FILTERS
- (15) ELECTRIC FAN AMBIENT AIR DISTRIBUTION
- (16) ELECTRIC FAN AIR EXHAUST
- (17) LIFTING BRACKETS (REMOVABLE, IF REQUIRED, AFTER POSITIONING THE UNIT)
- (18) FRESH AIR SHUTTER
- (19) OVER PRESSURE DAMPER AIR EXHAUST
- (20) ACCESS FOR INSPECTION OF COILS, FILTERS, HEATING ELEMENTS
- (R) AMBIENT AIR INTAKE
- (M) AMBIENT AIR DISTRIBUTION
- (AE) FRESH AIR INTAKE
- (ES) AIR EXHAUST
- (H1) WALL WITH SAME HEIGHT AS UNIT ON A MAXIMUM OF THREE SIDES
- (\*) VIBRATION MOUNTS POSITION
- (\*\*) SUGGESTED CLEARANCE

**WEIGHT DISTRIBUTION**

Size		302	362	402
W1	kg	382	385	395
W2	kg	378	395	398
W3	kg	466	485	490
W4	kg	469	490	502
Shipping weight	kg	1695	1755	1785

BT08C001CE-01

E108C001CB01

**CLIVET SPA**  
**Feltre (BL) ITALY**  
Tel. + 39 0439 3131  
Fax + 39 0439 313300  
info@clivet.it

**CLIVET ESPAÑA S.A.**  
**Madrid - SPAIN**  
Tel. + 34 91 6658280  
Fax + 34 91 6657806  
info@clivet.es

**CLIVET UK LTD**  
**Fareham (Hampshire) U.K.**  
Tel. + 44 (0) 1489 572238  
Fax + 44 (0) 1489 573033  
info@clivet-uk.co.uk

**CLIVET NEDERLAND B.V.**  
**Amersfoort - Netherlands**  
Tel. + 31 (0) 33 7503420  
Fax + 31 (0) 33 7503424  
info@clivet.nl

**CLIVET SPA**  
**BUREAU DE LIAISON EN FRANCE**  
**Verrières le Buisson - FRANCE**  
Tel. + 33 (0)1 69 20 25 75  
Fax + 33 (0)1 69 20 60 76  
info.fr@clivet.com

**CLIVET GmbH**  
**Norderstedt - GERMANY**  
Tel. +49 (0) 40 32 59 57-0  
Fax +49 (0) 40 32 59 57-194  
info.de@clivet.com

**CLIVET TFAIR SYSTEMS (P) LTD.**  
**Malur - INDIA**  
Tel. +91 8151 232683/5  
Fax +91-8151-232684  
info@clivetta.com