



## WDATA 2.160-2.600

AIR COOLED WATER CHILLER FOR OUTDOOR INSTALLATION



### WDATA R-134a

New series of air cooled liquid refrigerators.  
Class "A" of EUROVENT energy efficiency.  
Power of over 1400 kW with only 2 screw compressors.  
Continuous modulation power adjustment (Stepless).  
Specifically designed heat exchangers.  
High-efficiency refrigeration circuit with economizer.  
Modern, smart electronic management.



### WDATA 2.160 - 2.600 (R-134a)

Size	Cooling [kW]
2.160	400
2.180	456
2.190	505
2.200	556
2.240	616
2.280	699
2.300	767
2.320	835
2.340	882
2.360	935
2.440	1016
2.480	1138
2.540	1272
2.600	1411

The experience of Clivet in the sector of chillers of medium and high power has led to the development of the WDATA series, whose main characteristics are:

#### EFFICIENCY

class "A" Eurovent energy efficiency thanks to the new screw compressors, economizer circuit and shell and tube heat exchangers specially developed for R-134a gas: the best compromise for highlighting performance while limiting costs;

#### SELF-ADJUSTMENT:

new electronics developed by Clivet: the continuous adaptation of the parameters of operation of the chiller to the load conditions of the system in which it is installed allows for a reduction in consumption and noise with longer life of components;

#### STURDINESS

load bearing structure in hot-painted galvanized sheet metal, semi-hermetic screw compressors and shell and tube evaporator: a guarantee of reliability and constant performance in time.

BT08F006CB-00

Clivet is participating in the EUROVENT Certification Programme "Liquid Chilling Packages". Products are listed in the EUROVENT Directory of Certified Products and in the site [www.eurovent-certification.com](http://www.eurovent-certification.com). Eurovent Chillers Certification Programme covers air cooled packaged chillers up to 600 kW and water cooled packaged chillers up to 1500 kW.



**CERTIFIED QUALITY SYSTEM UNI EN ISO 9001:2000**

## STANDARD UNIT SPECIFICATIONS

## COMPRESSOR

Compact semi hermetic helicoidal twin screw compressors: the main screw (male, with five lobes) is driven directly by the electric motor, while the secondary screw (female with six vanes) is driven by the primary one.

The intrinsic volumetric ratio is precisely planned to be applied in the field of air-conditioning with ecological refrigerant R-134a. The screws are made from steel alloy and the axial bearings are in tandem configuration for greater sturdiness.

The seal is guaranteed by extremely accurate tolerances in the machining of all moving parts and by the specific circulation of oil between the screws.

Continuous modulation of cooling capacity (Stepless) with oilcontrol dynamic. The free flow lubrication system resulting from pressure differences, is equipped with a highly efficient separator, level indicator and oil filter (replaceable). An oil heater prevents excessive dilution of the oil by the refrigerant, and is automatically activated at all stages where the compressor is switched off.

The asynchronous three-phase two pole motor is suction gas cooled, reduced load start of the star delta type or Part Winding (according the compressor's size)

Fully protected electronic module, with safety sensor for monitoring discharge temperature, sensors for monitoring maximum temperature of the windings, device to monitor the motor rotation direction and device to monitor absence of phase.

Incorporated silencer non return valve and shut-off valve on the compressor discharge

Filter on the suction line, at the inlet to the compressor.

Automatic internal safety valve between HP & LP.



## ELECTRICAL PANEL

the Power Section includes:

- isolating transformer for auxiliary circuit power supply
- fan overload circuit breakers
- compressor fuses and thermal overload relay
- compressor control contactor
- fan control contactors

the control section includes:

- proportional + integral water temperature control
- antifreeze protection
- compressor overload protection and timer
- self-diagnosis system with immediate display of the error code
- prealarm function for water anti-ice and high refrigerant gas pressure
- compressor operating hour display
- phase monitor
- remote ON/OFF control
- automatic compressor start rotation control
- relay for remote cumulative fault signal
- display of the set values, the error codes and the parameter index
- input for demand limit (absorbed power limit according to an external signal 0÷10V or 4÷20mA)
- ON/OFF and alarm reset buttons
- UP and DOWN buttons to increase and decrease the values
- interface terminal with graphic display



## STRUCTURE

The bearing structure is made from hot-galvanized and painted plate and the external panelling from pre-painted aluminium, ensuring maximum weatherability. The uniform unit weight distribution is guaranteed by the base structure, realized with galvanized and painted plate section bars, featuring holes and/or stirrups to simplify the unit lifting and earthing.

The entire structure has been sized with modern calculation tools and finished elements to ensure the maximum safety and sturdiness of the system.

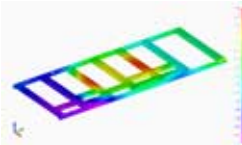

## INTERNAL EXCHANGER

Direct expansion exchanger with refrigerant side independent circuit for each compressor. The exchanger is composed of a cover made of carbon steel. The tubes, anchored to the tube plate by mechanical expansion, are made of copper, high efficiency, internally rifled to improve thermal exchange and specially designed for use with modern ecological refrigerants. It also includes a water side protection differential switch, an anti-freeze heating element to protect against icing, and covering in closed-cell thermo-insulating material that prevents the formation of condensation and heat exchange with the exterior.



## EXTERNAL EXCHANGER

Finned exchanger, made from copper pipes arranged in staggered rows and mechanically expanded for better adherence to the collar of the fins. The exchangers are planned, designed and produced directly by CLIVET. The fins are made from aluminium with a special corrugated surface, set a suitable distance apart to ensure maximum heat exchange efficiency. The coils are complete with integral subcooling circuit which assures the correct refrigerant feeding of the expansion valve. Available in different options as in optional list.



## FAN

Helical fans with sickle-shaped blades with "Winglets" at the end, coupled directly to a three phase electric external rotor motor with thermal protection incorporated in version IP 54. Housed in aerodynamically shaped nozzles to increase efficiency and minimize noise levels. They are fitted with protective safety guard grilles.



## REFRIGERANT CIRCUIT

The units are made with independent refrigerant circuits, each with:

- circuit with economizer exchanger (only in provided sizes)
- electronic expansion valve (see details further on)
- low pressure switch
- high pressure switch
- low pressure safety valve (safety valve with shut-off valve sealed with lead, open for possible inspection)
- high pressure safety valve (safety valve with shut-off valve sealed with lead, open for possible inspection)
- high and low pressure gauges
- replaceable anti-acid solid cartridge dehydrator filter
- sight glass with moisture indicator
- compressor discharge shut-off valve
- liquid line shut-off valve



## ACCESSORIES

- copper / copper condenser coils
- copper / aluminium condenser coils with acrylic lining
- copper / aluminium condenser coils with Fin Guard (Silver) treatment
- condenser coil and compressor compartment protection grill.
- compressor suction shut-off valve
- Hydropack (group of pumps on board: see additional information below), in options with motors with 2 and 4 poles.
- Anti-ice electric heaters utility side for hydronic group
- power factor correction capacitors (cosfi > 0.9)
- compressor overload circuit breakers
- main door lock isolator switch (compulsory per have certification CE)
- Master-Slave function
- Free contacts for compressor state
- Free contacts for compressor state and enabling
- clean contacts for compressor enabling and status, local/off/BMS selector.
- set point compensation with 4-20 mA or 0-10 V signal
- set point compensation with outside temperature probe
- set point compensation according to the outside enthalpy
- data logger (device for the acquisition of status and regulation values, as well as for recording the operation conditions in the surrounding of alarm events)
- remote microprocessor control unit
- phase cutting fan speed controller
- spring antivibration mounts
- ECOBreeze (see details further on)
- CAN/MODBUS serial converter kit
- CAN/LON WORKS serial converter kit

## TEST

All the units are factory-tested in specific steps, before shipping them. After the approval, the moisture contents present in all circuits are analyzed, in order to ensure the respect of the limits set by the manufacturers of the different components.



**CONFIGURATION CODE**

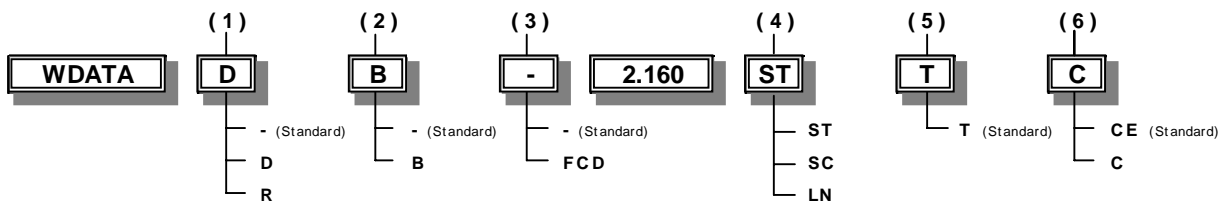

**(1) ENERGY RECOVERY**

**Partial energy recovery(D)**

it is achieved using tube bundle exchangers, suitable for recovering the heat from the desuperheating zone, up to a maximum of 20% of the total heat of the unit.

**Total energy recovery(R)**

made using tube bundle exchangers to recover 100% of the condensing heat for production of hot water. The version in question is supplied as standard with a variable-speed low temperature device. In addition, exchangers are complete with safety differential pressure switch on the water side, antifreeze heater to protect against the risk of ice.

**(2) LOW TEMPERATURE**

**Water low temperature(B)**

this version allows unit operation in the range of water and glycol mix temperatures between +4 and -8°C.

Two Versions are available:

- Unit only for low temperatures
  - Unit with double set-point operating set-point
- (Please contact our Sales office for special conditions)

**(3) FREE COOLING**

**direct Free-cooling(FCD)**

Version that allows to recovery free-cooling from ambient when the ambient air temperature is lower than the system outlet water temperature.

**(4) ACOUSTIC CONFIGURATION**

**Standard acoustic configuration(ST)**

see description "STANDARD UNIT SPECIFICATIONS"

**Acoustic configuration with compressor soundproofing(SC)**

this configuration is obtained by inserting the compressors in a soundproof enclosure.

**Low noise acoustic configuration(LN)**

this configuration is obtained by inserting the compressors in a soundproofed enclosure and reducing the speed of the fans, with a larger condensing section.

**(5) ENERGY EFFICIENCY**

**Energy efficiency for temperate climate(T)**

standard

**(6) HEAT EXCHANGERS APPROVALS**

Heat exchangers approvals C = CLIVET (Internal Testing)(CLV)

Heat exchangers approvals CE = PED (European Testing)(PED)

**COMPATIBILITY OF WDATA OPTIONS**

OPTIONS	DESCRIPTION	2.160	2.180	2.190	2.200	2.240	2.280	2.300	2.320	2.340	2.360	2.440	2.480	2.540	2.600
FCD + ST	Direct Free-cooling, Standard acoustic configuration,	⊗	⊗	⊗	⊗	⊗	⊗	⊗	⊗	⊗	⊗	⊗	⊗	⊗	⊗
FCD + SC	Direct Free-cooling, Acoustic configuration with compressor soundproofing	✓	✓	✓	✓	✓	✓	✓	✓	✓	✓	✓	✓	✓	✓
FCD + LN	Direct Free-cooling, Low noise acoustic configuration,	✓	✓	✓	✓	✓	✓	✓	✓	✓	✓	✓	✓	✓	⊗
FCD + B	Direct Free-cooling, Water low temperature,	⊗	⊗	⊗	⊗	⊗	⊗	⊗	⊗	⊗	⊗	⊗	⊗	⊗	⊗
FCD + D	Direct Free-cooling, Partial energy recovery,	⊗	⊗	⊗	⊗	⊗	⊗	⊗	⊗	⊗	⊗	⊗	⊗	⊗	⊗
FCD + R	Direct Free-cooling, Total energy recovery,	⊗	⊗	⊗	⊗	⊗	⊗	⊗	⊗	⊗	⊗	⊗	⊗	⊗	⊗
FCD + CCCA	Direct Free-cooling, Copper / aluminium condenser coil with acrylic lining,	⊗	⊗	⊗	⊗	⊗	⊗	⊗	⊗	⊗	⊗	⊗	⊗	⊗	⊗
FCD + CCCA1	Direct Free-cooling, Copper / aluminium condenser coils with Fin Guard (Silver) treatment,	⊗	⊗	⊗	⊗	⊗	⊗	⊗	⊗	⊗	⊗	⊗	⊗	⊗	⊗
FCD + CCCC	Direct Free-cooling, Copper /copper condenser coil,	⊗	⊗	⊗	⊗	⊗	⊗	⊗	⊗	⊗	⊗	⊗	⊗	⊗	⊗
FCD + 2PM	Direct Free-cooling, Hydropack with 2 pumps,	⊗	⊗	⊗	⊗	⊗	⊗	⊗	⊗	⊗	⊗	⊗	⊗	⊗	⊗
FCD + 3PM	Direct Free-cooling, Hydropack with 3 pumps,	⊗	⊗	⊗	⊗	⊗	⊗	⊗	⊗	⊗	⊗	⊗	⊗	⊗	⊗
D + R	Partial energy recovery, Total energy recovery,	⊗	⊗	⊗	⊗	⊗	⊗	⊗	⊗	⊗	⊗	⊗	⊗	⊗	⊗
D + 2PM	Partial energy recovery, Hydropack with 2 pumps,	⊗	⊗	⊗	⊗	⊗	⊗	⊗	⊗	⊗	⊗	⊗	⊗	⊗	⊗
D + 3PM	Partial energy recovery, Hydropack with 3 pumps,	⊗	⊗	⊗	⊗	⊗	⊗	⊗	⊗	⊗	⊗	⊗	⊗	⊗	⊗
R + 2PM	Total energy recovery, Hydropack with 2 pumps,	⊗	⊗	⊗	⊗	⊗	⊗	⊗	⊗	⊗	⊗	⊗	⊗	⊗	⊗
R + 3PM	Total energy recovery, Hydropack with 3 pumps,	⊗	⊗	⊗	⊗	⊗	⊗	⊗	⊗	⊗	⊗	⊗	⊗	⊗	⊗
CBS + SFSTR	overload circuit breakers, Soft Start,	⊗	⊗	⊗	⊗	⊗	⊗	⊗	⊗	⊗	⊗	⊗	⊗	⊗	⊗

BT08F006GB-00

**HYDRONIC**  
2.160 - 2.600

**Energy efficiency class**

In the scenario of rapid climate change in which we live today, the commitment to respect for the environment and a more rational use of resources focuses even greater attention on the energy efficiency of buildings and systems.

The interest that Clivet has always dedicated to energy efficiency pays off in this new series of water-cooled water chillers, WDATA. Class "A" according to EUROVENT energy efficiency classification.

LOW CONSUMPTION

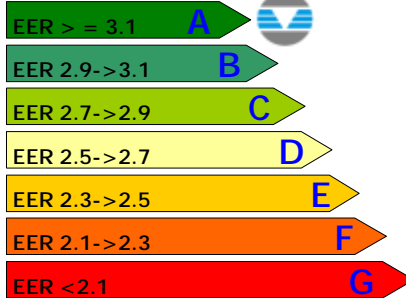

HIGH CONSUMPTION

**Standard electronic expansion valve**

Efficiency is in the standard scope of supply as a result of the electronic expansion valve. This element optimizes the superheating in any load condition thus offering a large number of advantages which can be summed up as follows:

- Fast and precise action due to the microprocessor based control with PID algorithms and to the step-motor.
- High energetic efficiency in all conditions, thanks to the reduction of transients, in terms of amplitude and duration, following load variations.
- Extended operating limits of the unit concerning minimum partial load and minimum air temperature at condenser.
- Better operating conditions for the compressor, thanks to the lower discharge gas temperature and preventing liquid return and insufficient lubrication.
- Easy unit set-up, even in special application seen the flexibility of the valve and its control parameters .
- More responsible use of refrigerant as the overall quantity required is smaller.
- Enhanced reliability of the operation of refrigerant circuit due to simplification of its components, to the control of the maximum operating pressure (MOP) and to the individual alarm condition indication.



**Transient and effect on superheating**

The instability of the superheating coming from the variation of the capacity supplied is reduced and is rapidly zeroed by the PID control and its fast reaction. This allows a steady operation, within the safety limits, around the most favorable value.

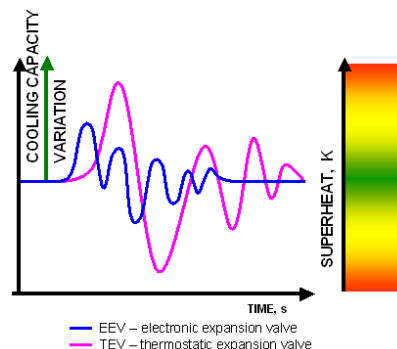

**New generation of fans**

This Series is equipped with a new axial fan designed in the best european laboratories in cooperation with the make. The result of the research has permitted to develop a new wing contour "Winglets type" at the end of the blade.

This allows great result both with an average noise reduction of 6dB(A) and an energy saving of 10%.

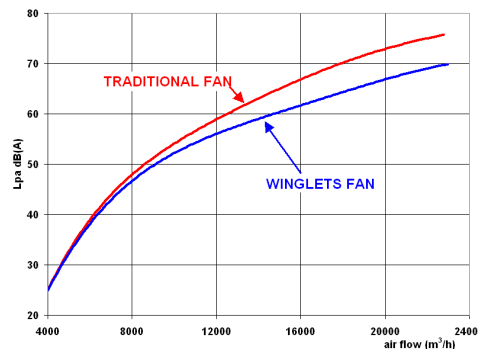
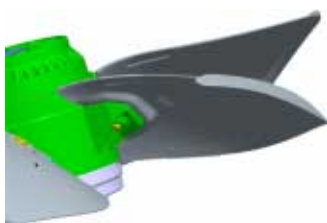

**Seasonal efficiency=ESEER**



ESEER: Guarantee in the performance means to be able to plan realistically the energy consumption and then the costs. The ESEER = European Seasonal Energy Efficiency Ratio, contrarily to the simple EER, is calculated as a combination of different operating conditions, which have been recently declared by Eurovent/CEN, in order to demonstrate the chiller efficiency while operating also in off-design conditions, normal in the mid-season.

Conditions				
	Weight	Load (%)	Air	Water
a	3	100	35	12 / 7
b	33	75	30	10.8 / 7
c	41	50	25	9.5 / 7
d	23	25	20	8.3 / 7

EERa =	3.11	x 0.03+
EERb =	3.67	x 0.33+
EERc =	3.69	x 0.41+
EERd =	3.62	x 0.23+
<b>ESEER = 3.65</b>		

Example of calculation referred to unit WDATA 2.200 ST.

- a,b,c,d, = partial load conditions and air temperature used for the ESEER calculation.
- Weight % = space of time during which the unit works at the described conditions (used in the weighted sum).
- Load % = partialization of the unit drop (referred to nominal capacity).
- Air temperature = condensate coil intake air temperature.
- Water temperature = evaporator water temperature.
- EERa,b,c,d = EER calculated according to the partial load conditions

BT08F006GB-00

**Accessory: ECOBreeze**

Within the range of air condensation-based products, Clivet introduces an innovative technology based on the deployment of fans driven by Brushless motors, completely electronically-controlled, characterised by extremely high efficiency and which allow a very advanced adjustment of fan speeds.

The ECOBreeze option envisages the utilisation of special fans driven by electrical Brushless motors. This technology envisages a permanent-magnets rotor, coupled with a very advanced magnetic field electronic switching control to the stator, directly integrated within the motor itself. A veritable "feather in the cap" is the electronic switching device that manages the precise and effective modulation of the fan's rotation speed and, therefore, of the fan's capacity. The management of this device is entrusted to the unit's general control system, thus assuring complete integration with the other refrigerating unit's components; this also allows the attaining of an exceptional overall efficiency. Furthermore, by integrating the control directly within the fan, one is guaranteed absolute suitability in the regulator/fan pair, differently from what is experienced in traditional systems. Finally, under particularly demanding or emergency conditions, for example should the environment temperature rise beyond the limits foreseen, before shutting the delivered power and/or setting the unit under alarm, the control device will detect the specific situation and will force the fans to a rotation speed beyond the nominal value, thus assuring an additional capacity of about 15% of the specified value. In this way, it is possible to assure the production of refrigerated water also when traditional units would be forced into alarm conditions.

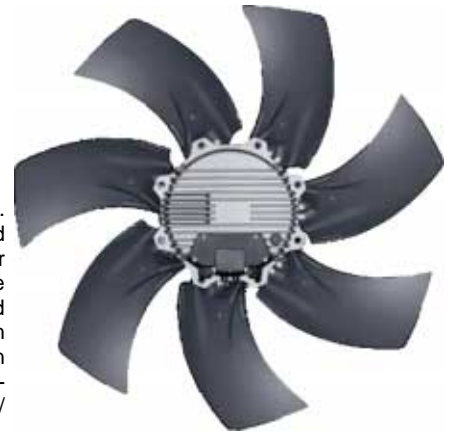

**Electric motor intrinsic efficiency guarantees a consumption reduction in every operation conditions.**

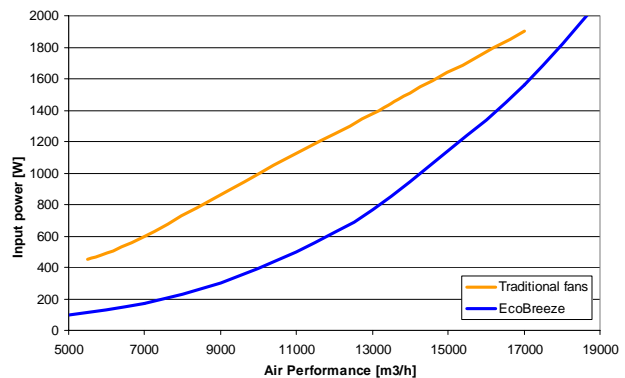
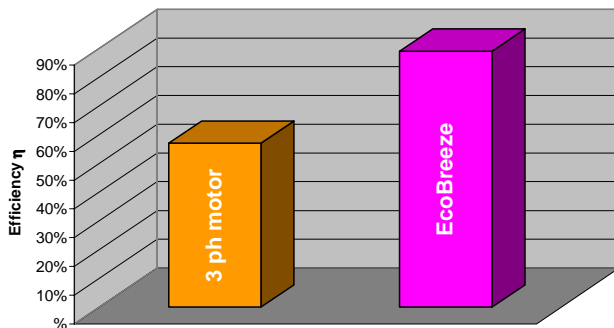

The final result confirms that in comparison to the traditional three-phase induction motors, also with frequency and/or voltage governing, the internal losses within the iron are reduced by 60%, those of the copper by 40%, whereas the intrinsic consumption is about half of that of a traditional modulator (inverter, phase adjuster). The energy cutback, and therefore the money saved, under all operating conditions are truly remarkable and the initial investment is repaid in very few months. From that moment onwards the reduced operative costs turn directly into an economic gain for the user.

**When fans turn at minimum necessary speed, noise emissions are reduced.**

In addition to this, a generalised reduction in noise emission is obtained, due to the effect of both the rotation speed which is always modulated to the most suitable value, in keeping with the operation conditions, and the technology deployed in the governing which doesn't induce particular frequencies and vibrations in the rotation.

**The start-up is progressive, without start absorption peaks.**

The current damping at start-up (see diagram) due to the control typology, but also to the absence of brushing contacts for the power supply to the rotor, drastically reduce the harmful stresses for the lifetime of the component. In the final analysis, the fan's life can be considered as practically unlimited (greater than 80,000 hours).

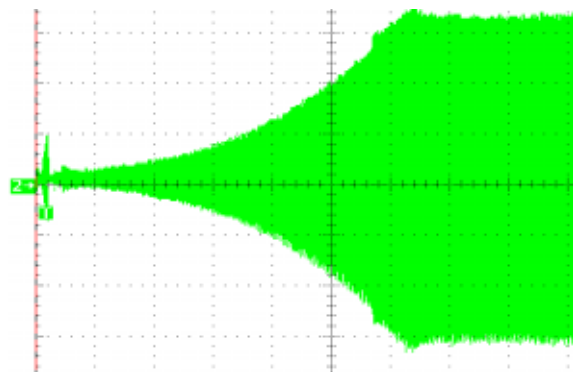
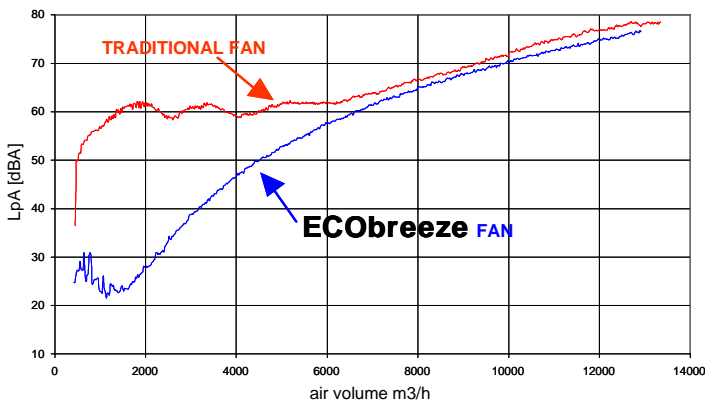

BT08F006GB-00

## HYDRONIC 2.160 - 2.600

### Accessory: Hydropack

#### New concept of pumping station

By equipping the refrigerating units with the Hydropack accessory, the necessary flow capacity/head are provided in different versions according to the plants potential.

**HYDROPACK with 2 pumps:** in case of blockage of a pump, the unit continues to operate normally up to about 60% of the load; this condition is in any case more reliable than the traditional solution with a single-pump of greater power.

**HYDROPACK with 3 pumps:**

if one pump shuts down, the unit continues to operate normally up to about 80% of the load.

More specifically, all main components (including the pre-setting of the connection to the system) are hydraulically connected through swift-latch connections instead of the traditional welding, flanging and threading, with obvious advantages for the user.

- They can be easily dismantled, affording an advantage in the inspection and maintenance operations.
- Work times are reduced by 90%.
- The deployment of specialised personnel is not necessary.
- The moving of single components is made very simple.
- Weight is reduced since at even piping dimensions the joints weigh half as much as the flanges.
- Utilisation of standard components that are available anywhere in the market.

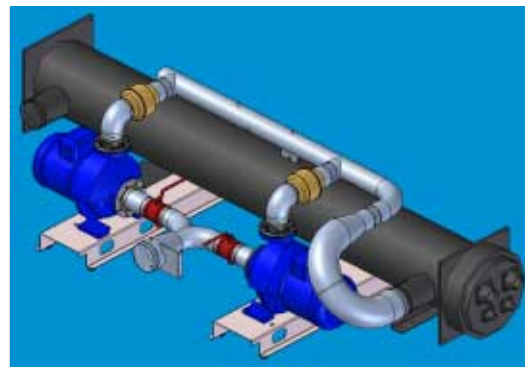

#### HEAD DIAGRAM-FLOW RATE (2 POLE PUMP)

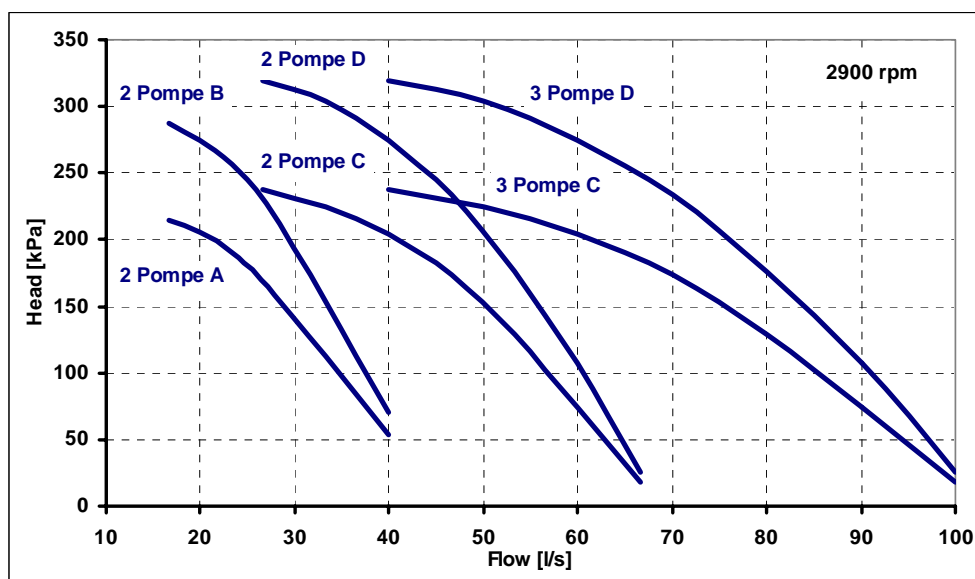

Attention: the evaporator pressure drops have to be taken from the heads represented in these diagrams in order to obtain the available head values.

#### HEAD DIAGRAM- FLOW RATE (4 POLE PUMP)

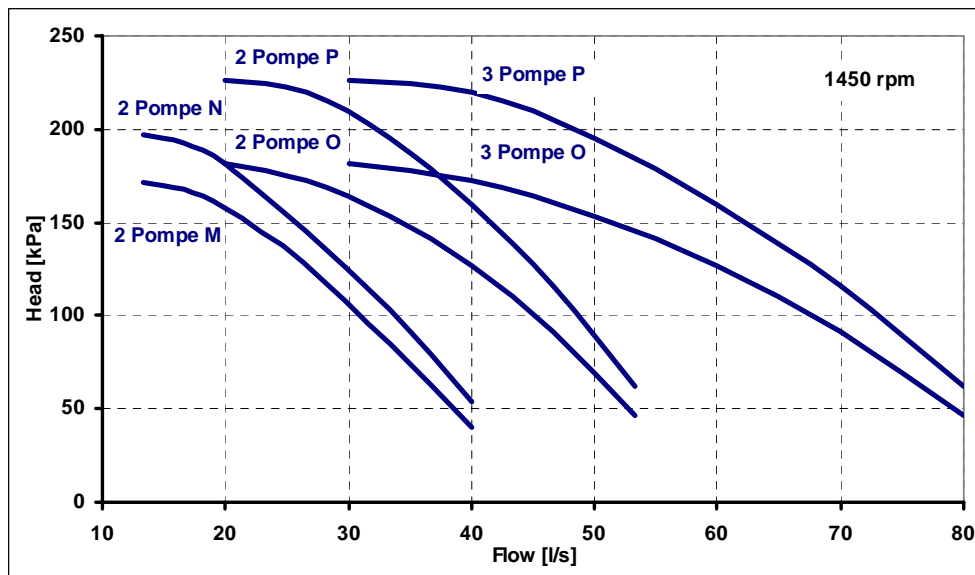

Attention: the evaporator pressure drops have to be taken from the heads represented in these diagrams in order to obtain the available head values.

**CONNECTION DIAGRAM - GROUP WITH 2 PUMPS**

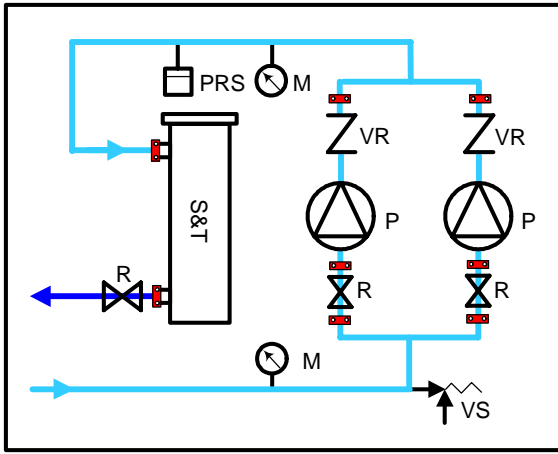

**CONNECTION DIAGRAM - GROUP WITH 3 PUMPS**

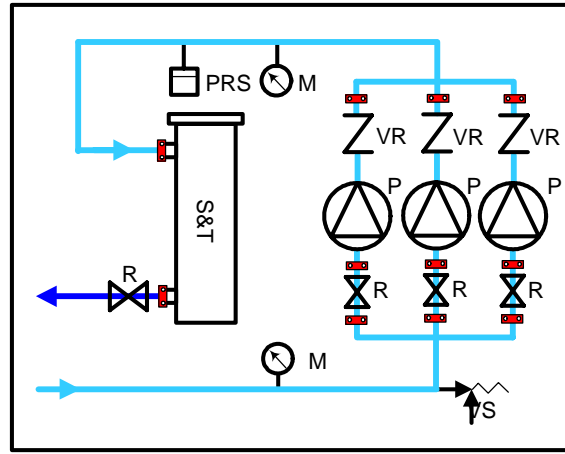

- Multi-pump hydraulics group composed of:
- R = shut-off valves,
  - M = pressure gauges,
  - VS = safety valve (6 Bar),
  - P = monobloc electric pumps with high-performance single rotor,
  - VR = non-return valve,
  - PRS = system charge safety pressure switch (keeps pumps from operating if there is no water),
  - S&T = evaporator

**hydropack electrical data**

Hydropack			
N° Pumps	Type	[kW]	[A]
2	A	8.0	15.4
2	B	11.0	20.8
2	C	15.0	27.8
2	D	22.0	40.4
2	M	8.0	17.0
2	N	11.0	22.6
2	O	11.0	22.6
2	P	15.0	30.8
3	C	22.5	41.7
3	D	33.0	60.6
3	O	16.5	33.9
3	P	22.5	46.2

**COMPATIBILITY OF WDATA HYDROPACK OPTIONS**

OPTIONS	DESCRIPTION	2.160		2.180		2.190		2.200		2.240		2.280		2.300		2.320		2.340		2.360		2.440		2.480		2.540		2.600		
		ST	SC	LN	ST	SC	LN	ST	SC	LN	ST	SC	LN	ST	SC	LN	ST	SC	LN	ST	SC	LN	ST	SC	LN	ST	SC	LN	ST	SC
2PM + PUA2	Hydropack with 2 pumps, 2 poles type A pump.	✓	✓	✓	✓	✓	✓	✓	✓	✓	✓	✓	✓	✓	✓	✓	✓	✓	✓	✓	✓	✓	✗	✗	✗	✗	✗	✗	✗	✗
2PM + PUB2	Hydropack with 2 pumps, 2 poles type B pump.	✓	✓	✓	✓	✓	✓	✓	✓	✓	✓	✓	✓	✓	✓	✓	✓	✓	✓	✓	✓	✓	✗	✗	✗	✗	✗	✗	✗	✗
2PM + PUC2	Hydropack with 2 pumps, 2 poles type C pump.	✗	✗	✗	✗	✗	✗	✗	✗	✗	✗	✗	✗	✗	✗	✗	✗	✗	✗	✗	✗	✗	✗	✗	✗	✗	✗	✗	✗	
2PM + PUD2	Hydropack with 2 pumps, 2 poles type D pump.	✗	✗	✗	✗	✗	✗	✗	✗	✗	✗	✗	✗	✗	✗	✗	✗	✗	✗	✗	✗	✗	✗	✗	✗	✗	✗	✗	✗	
3PM + PUA2	Hydropack with 3 pumps, 2 poles type A pump.	✗	✗	✗	✗	✗	✗	✗	✗	✗	✗	✗	✗	✗	✗	✗	✗	✗	✗	✗	✗	✗	✗	✗	✗	✗	✗	✗	✗	
3PM + PUB2	Hydropack with 3 pumps, 2 poles type B pump.	✗	✗	✗	✗	✗	✗	✗	✗	✗	✗	✗	✗	✗	✗	✗	✗	✗	✗	✗	✗	✗	✗	✗	✗	✗	✗	✗	✗	
3PM + PUC2	Hydropack with 3 pumps, 2 poles type C pump.	✗	✗	✗	✗	✗	✗	✗	✗	✗	✗	✗	✗	✗	✗	✗	✗	✗	✗	✗	✗	✗	✗	✗	✗	✗	✗	✗	✗	
3PM + PUD2	Hydropack with 3 pumps, 2 poles type D pump.	✗	✗	✗	✗	✗	✗	✗	✗	✗	✗	✗	✗	✗	✗	✗	✗	✗	✗	✗	✗	✗	✗	✗	✗	✗	✗	✗	✗	
2PM + PUM4	Hydropack with 2 pumps, 4 poles type M pump.	✓	✓	✓	✓	✓	✓	✓	✓	✓	✓	✓	✓	✓	✗	✗	✗	✗	✗	✗	✗	✗	✗	✗	✗	✗	✗	✗	✗	
2PM + PUN4	Hydropack with 2 pumps, 4 poles type N pump.	✓	✓	✓	✓	✓	✓	✓	✓	✓	✓	✓	✓	✓	✗	✗	✗	✗	✗	✗	✗	✗	✗	✗	✗	✗	✗	✗	✗	
2PM + PUO4	Hydropack with 2 pumps, 4 poles type O pump.	✓	✓	✓	✓	✓	✓	✓	✓	✓	✓	✓	✓	✓	✓	✓	✓	✓	✓	✓	✓	✓	✗	✗	✗	✗	✗	✗	✗	
2PM + PUP4	Hydropack with 2 pumps, 4 poles type P pump.	✓	✓	✓	✓	✓	✓	✓	✓	✓	✓	✓	✓	✓	✓	✓	✓	✓	✓	✓	✓	✓	✗	✗	✗	✗	✗	✗	✗	
3PM + PUM4	Hydropack with 3 pumps, 4 poles type M pump.	✗	✗	✗	✗	✗	✗	✗	✗	✗	✗	✗	✗	✗	✗	✗	✗	✗	✗	✗	✗	✗	✗	✗	✗	✗	✗	✗	✗	
3PM + PUN4	Hydropack with 3 pumps, 4 poles type N pump.	✗	✗	✗	✗	✗	✗	✗	✗	✗	✗	✗	✗	✗	✗	✗	✗	✗	✗	✗	✗	✗	✗	✗	✗	✗	✗	✗	✗	
3PM + PUO4	Hydropack with 3 pumps, 4 poles type O pump.	✗	✗	✗	✗	✗	✗	✗	✗	✗	✗	✗	✗	✗	✗	✗	✗	✗	✗	✗	✗	✗	✗	✗	✗	✗	✗	✗	✗	
3PM + PUP4	Hydropack with 3 pumps, 4 poles type P pump.	✗	✗	✗	✗	✗	✗	✗	✗	✗	✗	✗	✗	✗	✗	✗	✗	✗	✗	✗	✗	✗	✗	✗	✗	✗	✗	✗	✗	

BT08F006GB-00

## HYDRONIC 2.160 - 2.600

### WDATA FREE-COOLING

#### FREE-COOLING

When the temperature of the fresh air is lower than the temperature of the return water of the system, the free-cooling version lets you recover cold from the external environment, reducing the work of the compressors all the way down to nothing. IT IS INTENDED

for all applications that require chilled water even in cold weather, such as industrial processes, data processing centres, telephone plants, shopping centres, etc.



#### USE OF ANTI-FREEZE SOLUTIONS

The heat carrier used in the systems that include a Free-Cooling device require a glycol solution (usually an ethylene type). This substance is required because the Free-Cooling units are intended to be installed where the temperature can drop to very low levels during certain times of the year. The percentage of glycol in the solution depends on the low temperatures that can be expected in the place of installation. Therefore, this parameter is at the discretion of the system designer.

#### OPERATING LOGIC OF CLIVE UNITS

The Free-Cooling unit differs mechanically from the standard unit due to the addition of a 3-way valve and a special finned packaged air/water heat exchanger. Seasonal weather conditions cause the unit to operate in one of three different modes:

- Summer mode.
- Spring/autumn mode.
- Winter mode.

For the unit to work correctly in all situations, in complete safety, and with complete recovery of cooling power, the use of a modern, sophisticated microprocessor is required, which monitors a number of parameters (especially temperature and pressure) for the fresh air, gas and water circuit. The main difference between summer mode and the other modes is the position of the 3-way valve. In the summer, the valve is positioned so that it bypasses the Free Cooling coils, which in the other seasons are involved in cooling the solution.

#### OPERATING LOGIC IN SUMMER MODE

- cooling of the solution is ensured by the refrigerating cycle with operation of the compressors (C) as in a traditional chiller
- as you can see in the figure, the Free-Cooling (Bh) coils are not involved.

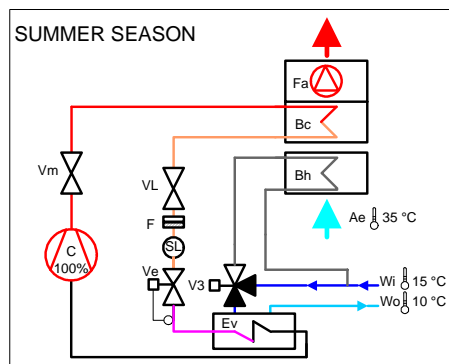

#### OPERATING LOGIC IN SPRING/AUTUMN MODE

- energy savings variable between 0 and 100%, based on the temperature difference between fresh air and the system request
- if the unit detects that the fresh air temperature (Ae) is suitable:
  - 1) it inverts the position of the 3-way valve (V3), forcing the solution to travel through the Free-Cooling coils (Bh) before reaching the evaporator (Ev)
  - 2) it sets the fans (Fa) at maximum speed to obtain maximum cooling of the solution from the fresh air
  - 3) the solution thus undergoes an initial cooling which is free and natural
  - 4) the remaining cooling is provided by the refrigeration cycle, with compressors in stepped operation (power absorbed proportional to the degree of stepping)
- if the temperature of fresh air increases, the microprocessor will automatically revert operation to summer mode, ensuring the same conditions requested by the user

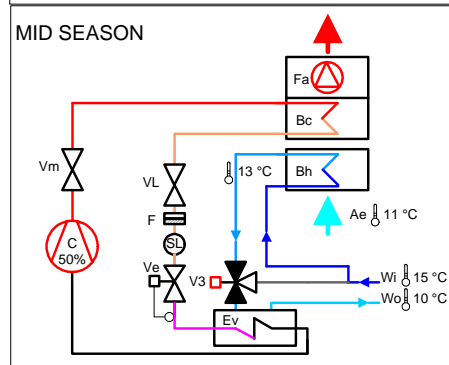

#### OPERATING LOGIC IN WINTER MODE

- the three way valve (V3) is in the same position as in the previous case;
- the temperature of the fresh brings the solution at the outlet of the Free-Cooling coils (Bh) to the temperature required for use;
- the microprocessor control completely deactivates all compressors (C), providing all cooling power at no cost, as opposed to standard units;
- if the difference between the temperature of the fresh air (Ae) and that required for use is such that the temperature of the solution at the outlet of the Free-Cooling coils (Bh) drops below the set point required for use (which does not compromise unit safety, because of the glycol in the solution), the microprocessor modulates fan speed (Fa), turning them off if necessary. When the fans are off, if the temperature (Wo) continues to drop, the 3-way valve (V3) positions itself as in summer operation, changing to digital and allowing the set point to be maintained.

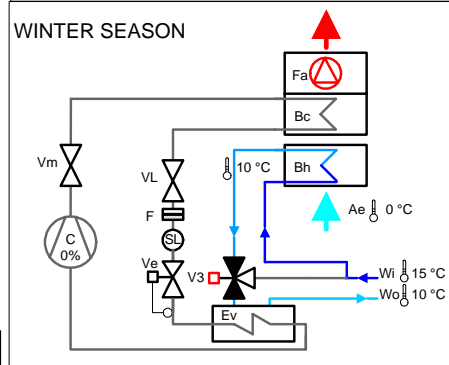

Key	SL = liquid warning light
Ae = fresh air	V3 = three-way valve
Bc = condensing coil	Ve = electronic expansion valve
Bh = water coil	VL = cock on the liquid line
C = scroll compressor	Vm = cock on the return line
Ev = plate evaporator	Wi = water inlet
F = filter dryer	Wo = water outlet
Fa = fan	

**DETERMINATION OF CHILLER PERFORMANCE WITH FREE-COOLING IN CONDITIONS OF FC = OFF**

The performance of a unit provided with a free-cooling device varies with respect to the information provided for the standard units as shown in the table:

Glycol	10%	20%	30%	40%
Cooling Capacity	0.97	0.96	0.95	0.94
Compressors input	1.040	1.034	1.030	1.027

**EXAMPLE:**

Determine the performance of a unit WDATA FCD 2,160 SC, free-cooling with water 12/7 °C (30% gl) and fresh air 35°C

WDATA S 2,160 SC (standard)  
Cooling power = 400 Kw  
Electrical power of compressors = 112 kW

WDATA FCD 2,160 SC (standard)  
Cooling power = 400 x 0.95 = 380. kW  
Electrical power of compressors = 112 x 1.03 = 115. kW

**DETERMINATION OF CHILLER PERFORMANCE WITH FREE-COOLING IN CONDITIONS OF FC = ON**

Size		2.160	2.180	2.190	2.200	2.240	2.280	2.300	2.320	2.340	2.360	2.440	2.480	2.540	2.600	
SC	Nominal Free-cooling capacity (1)	Kw	416	473	526	577	641	724	795	864	915	970	1050	1182	1320	1463
	Nominal air temperature of 100% Free-cooling (1)	°C	3.0	1.5	-0.6	-1.7	-1.0	-2.5	-3.8	-5.1	-6.2	-7.1	-3.7	-5.5	-3.5	-5.0
LN	Nominal Free-cooling capacity (1)	Kw	416	470	527	574	639	718	793	851	909	960	1055	1184	1334	-
	Nominal air temperature of 100% Free-cooling (1)	°C	-0.7	-1.5	-1.1	-1.9	-3.3	-5.1	-6.8	-8.0	-4.3	-5.1	-6.5	-4.6	-6.5	-

(1)Data referred to the following conditions :

- Water temperature IN-OUT 15/10°C;
- Percentage of glycol 30%;

**DETERMINATION OF THE PERCENTAGE OF FREE-COOLING - SC SETUP**

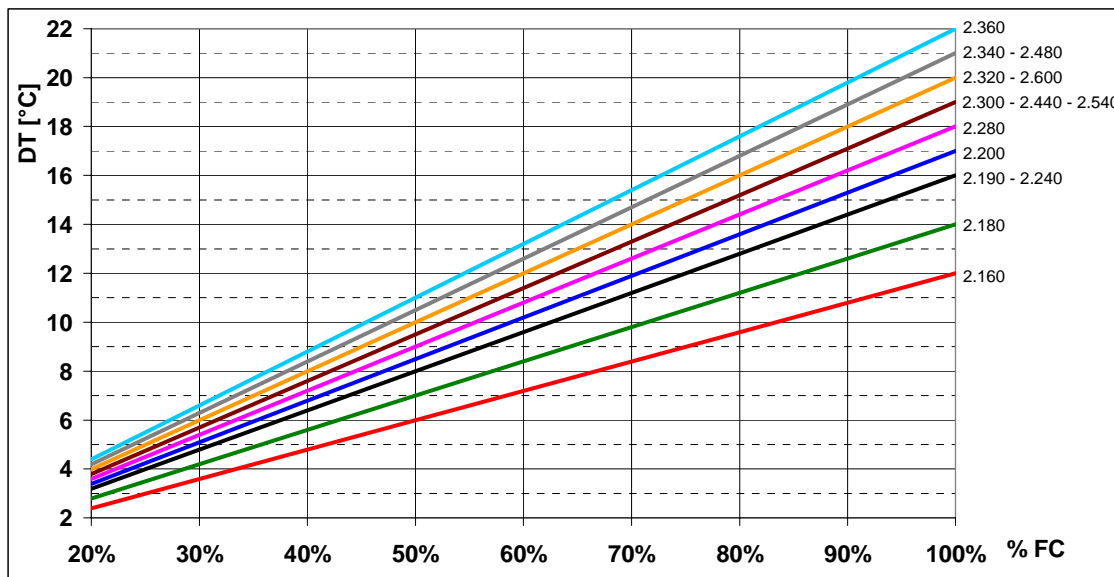

**DETERMINATION OF THE PERCENTAGE OF FREE-COOLING - LN SETUP**

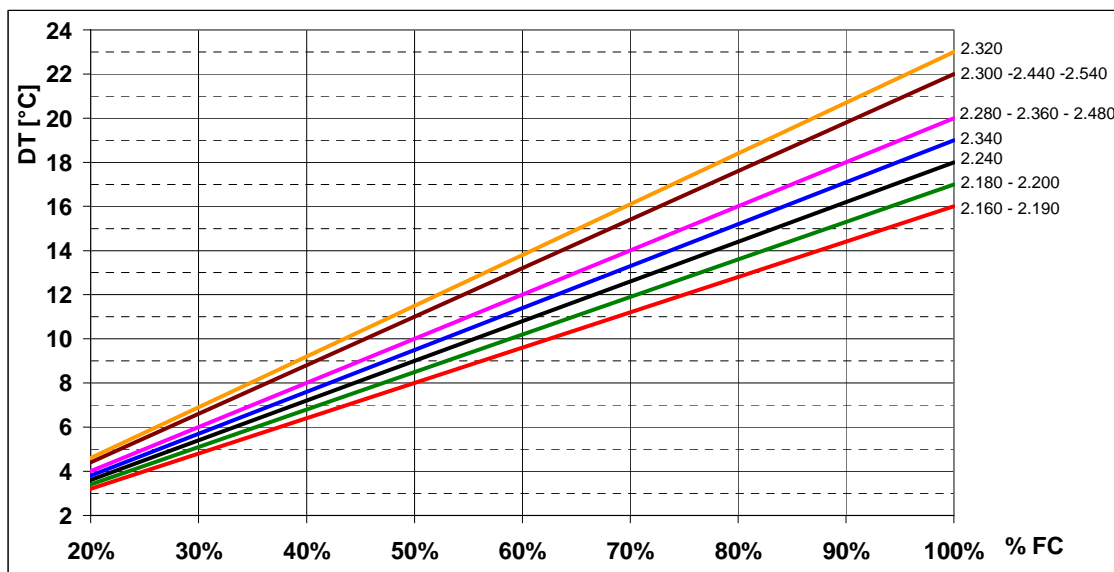

% FC = percentage with respect to nominal power of free-cooling (water = 15/10°C, 30% gl)  
DT = temperature delta between return water from the system and fresh air.

**EXAMPLE:**

Determine the FC performance of a unit WDATA 2,160 SC with water 12/7 °C -30% gl and fresh air 6°C.  
Temperature differential (evaporator inlet temperature - fresh air temperature) = 12°C - 6 °C = 6°C  
Nominal FC power (from table) = 416. kW with H2O = 15/10 °C - 30% gl, fresh air 3 °C.  
Nominal Fc percentage (from graph SC) = 50%  
FC power with fresh air of 6°C = 416x50/100 = 208. kW

BT08F006GB-00

**HYDRONIC**  
2.160 - 2.600

**Energy recovery**

**Partial energy recovery**

The use of a desuperheater in a system developed based on the maximum energy efficiency and with a request for hot water, is practically an obligatory choice because it makes it possible to recover, free of charge, the heat that would otherwise be dispersed in the environment. The partial heat recovery is composed of shell and tube heat exchangers suitable for recovery of 20% of the heat power dispersed by the unit (cooling and electrical power of the compressors). With the desuperheater active, the performance of the unit improves since the condensation temperature is lowered. Approximately, the cooling power increases by 3.2% and the power absorbed by the compressors decreases by 3.6%. If the temperature of the water to be heated is relatively low, it is advisable to insert in the plumbing circuit an adjustment valve to keep the recovery inlet temperature greater than 35°C to prevent condensation.

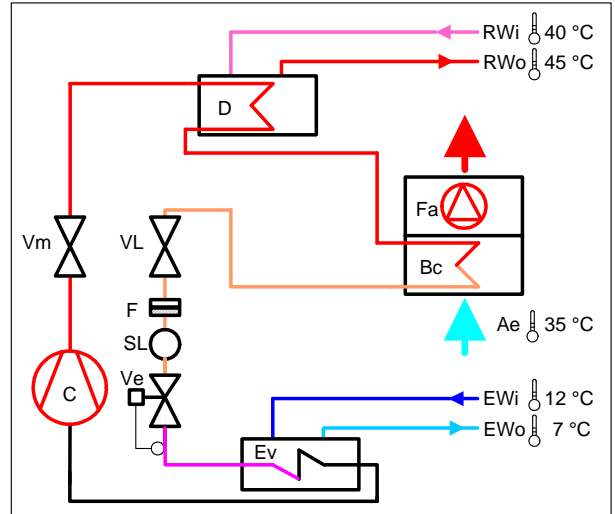

Cooling Capacity	+3.2%
Compressors power input	-3.6%

**Legend**

Ae = fresh air  
Bc = condensing coil  
C = compressor  
D = partial heat recovery  
Ev = evaporator  
EWi = chilled water inlet  
EWO = chilled water outlet  
F = dryer filter

Fa = fan  
RWi = partial recovery water inlet  
RWO = partial recovery water outlet  
SL = liquid indicator  
Ve = electronic expansion valve  
VL = bibcock on liquid line  
Vm = bibcock on supply line

**Total energy recovery**

The use of total heat recovery may be the optimal solution in all cases that require the production of hot water for medium and large potentials. The production of hot water is always of lesser priority than the production of chilled water.

The total heat recovery is composed of shell and tube heat exchangers suitable for recovery of 100% of the heat power dispersed by the unit (cooling and electrical power of the compressors).

The unit with total recovery is capable of managing the recovery temperature with thermal adjustment integrated in the microprocessor with two steps.

The adjustment of power is managed based on chilled water and may have the following instances:

- 1) Cold request 100%, hot request 0% = circuit 1 active only cold, circuit 2 active only cold,
  - 2) Cold request 100%, hot request 50% = circuit 1 active in cold + recovery, circuit 2 active in cold only,
  - 3) Cold request 100%, hot request 100% = circuit 1 active in cold + recovery, circuit 2 active in cold+recovery,
  - 4) Cold request 50%, hot request 100% = circuit 1 active in cold+recovery, circuit 2 off (in this case the unit can provide only 50% of the requested heat).
- As you can see from the following diagram, with the recovery active the condensing coil (Bc) is deactivated and condensation takes place in the total recovery (R). With the recovery setpoint met, the condensing coil (Bc) is reactivated, to perform condensation, via the solenoid valves (Vr=off and Vc=on). In this case the recovery (R) acts as a simple desuperheater.

To allow correct operation in all conditions of use, the device for condensation control is standard and also the unit used special algorithms that manage the provided power to prevent machine alarm situations.

In the plumbing circuit, considering the powers involved, it is advisable to insert a storage tank with suitable capacity to prevent constant commutations of the unit.

**Total recovery active**

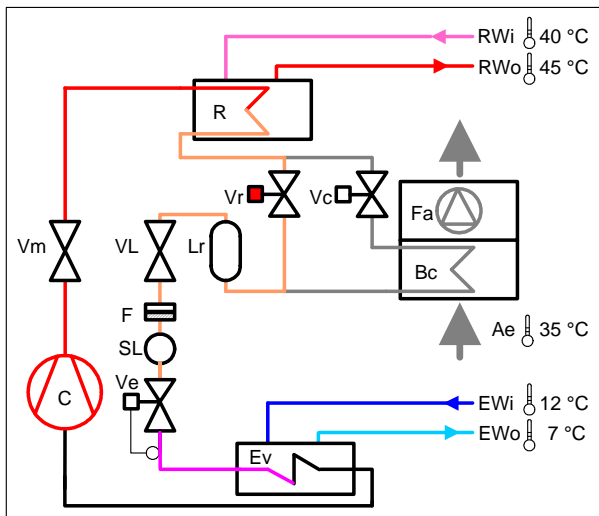

**Total recovery with setpoint met**

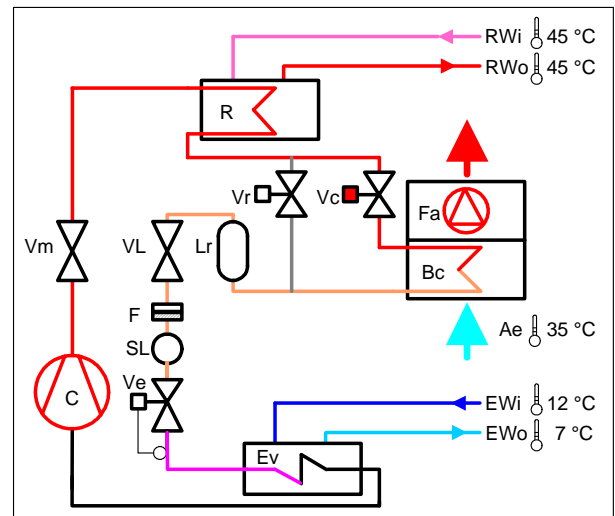

**Legend**  
Ae = fresh air  
Bc = condensing coil  
C = compressor  
Ev = evaporator  
EWi = chilled water inlet  
EWO = chilled water outlet  
F = dryer filter  
Fa = fan  
Lr = liquid container

R = total heat recovery  
RWi = total recovery water inlet  
RWO = total recovery water outlet  
SL = liquid indicator  
Vc = condensing coil enabling valve  
Ve = electronic expansion valve  
VL = bibcock on liquid line  
Vm = bibcock on supply line  
Vr = total recovery enabling valve

BT08F006GB-00

exchanger pressure drop partial energy recovery

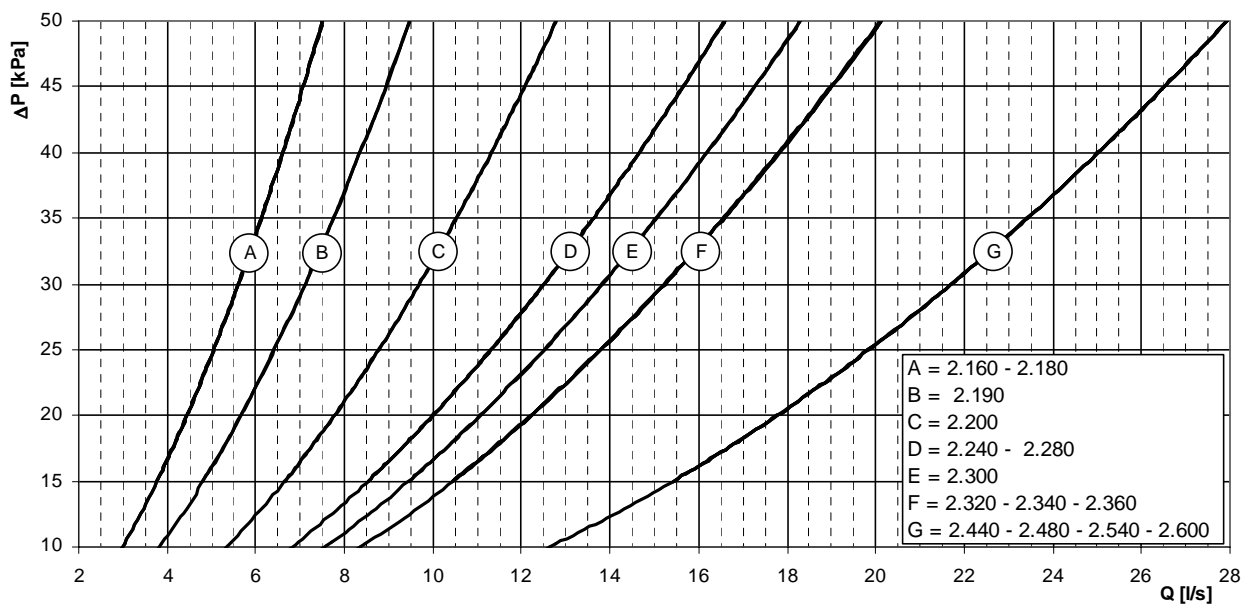

Q[l/s]= WATER-FLOW RATE  
dP = pressure drop

exchanger pressure drop total energy recovery

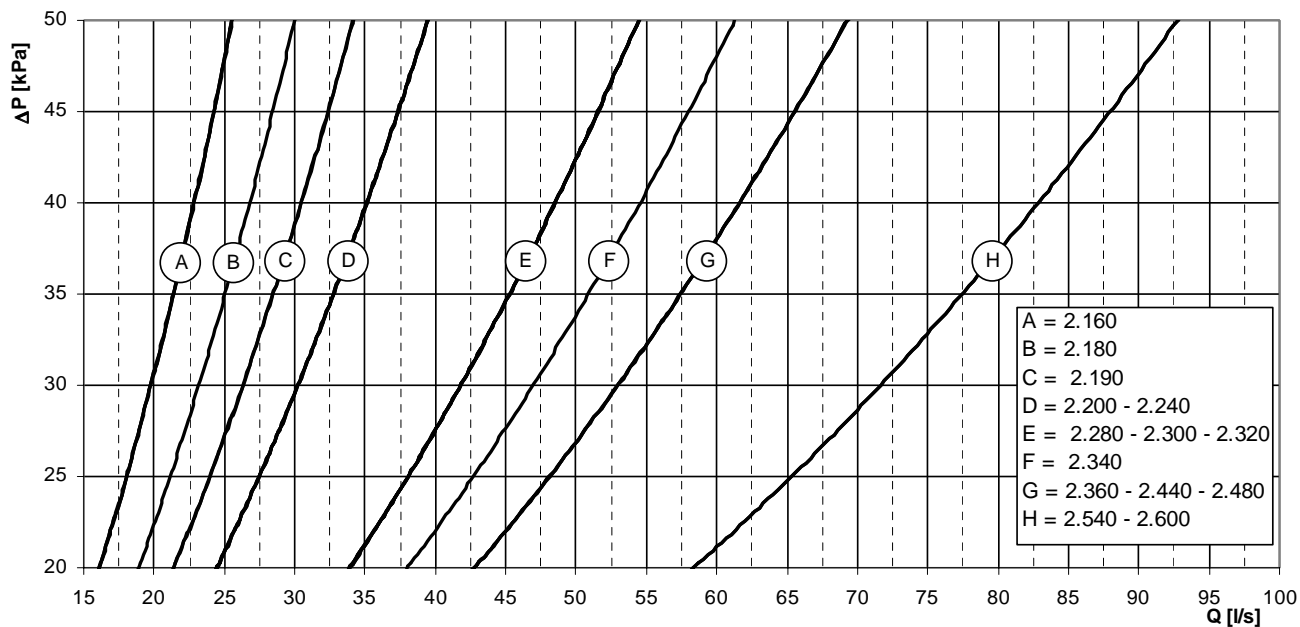

Q[l/s]= WATER-FLOW RATE  
dP = pressure drop

BT08F006GB-00

## HYDRONIC 2.160 - 2.600

### TECHNICAL CHARACTERISTICS OF ACCESSORIES

**SPC1 - set point compensation with 4-20 mA signal**

**SCP4 - compensation of set point with signal 0-10 V**

The set point compensation with signal 4-20 mA or 0-10 V changes the calibration of the set point, increasing or decreasing it depending on the system needs.

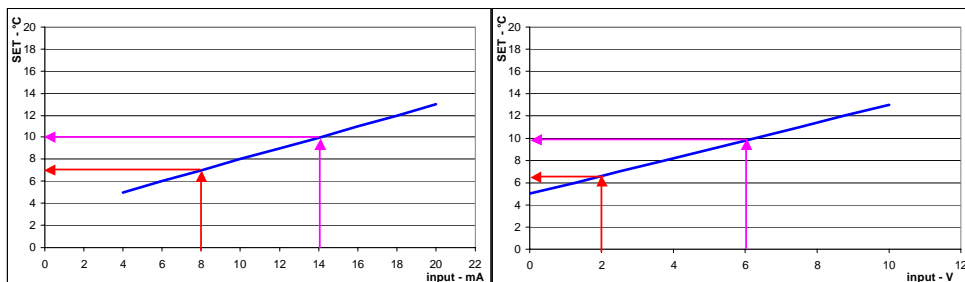

### SPC2 - set point compensation with outside temperature probe

Set point compensation by air temperature probe varies the value of the set point according to the outside air temperature, allowing energy savings

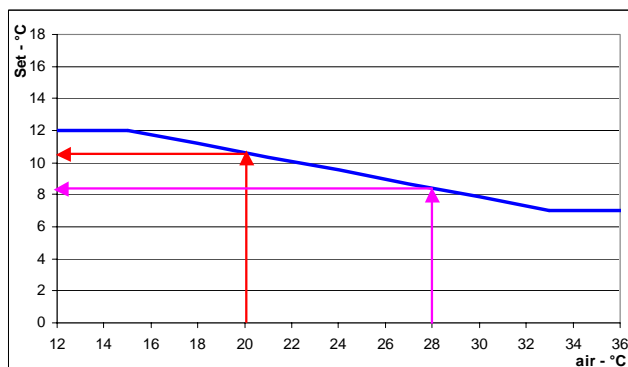

### SCP3 - set point compensation according to the outside enthalpy

It allows to modulate the unit set point according to the external enthalpy optimizing the unit energy efficiency. The humidity probe is electronically connected to the main control module present in the unit.



### PFCP - power factor correction capacitors (cosfi > 0.9)

the power factor correction capacitors increase the cosF value, reducing the apparent current on the supply line to the chiller assembly  
With costs of less than 0.9 the energy provider applies surcharges for the drawing of reactive energy.



### CBS - compressor overload circuit breakers

the thermal magnetic circuit breakers are used instead of the fuses for protection against short-circuits and overloads. If they are activated they do not need to be replaced, as is the case with fuses



**RCMRX - remote microprocessor control unit**

the remote control allows the remote display and operation of functions of the microprocessor on the unit

separately supplied accessories

**CMSC4 - CAN/MODBUS serial converter kit**

The serial communication module to supervisor (MODBUS) is connected with the principal module through a comb connection (see lay-out on electrical panel). In this way the remote assistance and supervision are available through standard MODBUS protocol. It is possible to connect to a single supervisor system up to 127 units. The connection to PC must be obtained through a converter RS485/232; the serial port RS232 admits as maximum a 10 m length. The serial communication module to supervisor (MODBUS) is necessary when the unit is connected to ELFOCONTROL.

**CMSC6 - CAN/LON WORKS serial converter kit**

LonWorks technology is a complete platform for the implementation of network system. These networks consist of smart control systems or "nodes" that interact with their environment and communicate with one another using a common message based on the protocol (LonTalk®). A LonWorks network may have up to 32,685 nodes divided in 255 sub-networks (127 nodes/sub-network). The gateway device is already configured according to the Echelon classification for the type of unit for which it is intended, with a number of managed variables which are the subset of those managed natively by the machine, and in any case able to receive the standard Echelon profiles. The supply of this device does not include configuration and operation of the LonWorks to which it is connected. These actions are left to the supplier of the supervision system.

**MSLX - Master-Slave function**

The master-slave function allows to control and optimize the operation of several units on the same water circuit. The Clivet Talk local network can be extended to up to 6 units.

separately supplied accessories

**DLX - data logger**

The data logger is a sort of black box which records all parameters and tracks them in case of an alarm.

separately supplied accessories



## HYDRONIC

### 2.160 - 2.600

#### PGCC - condenser coil and compressor compartment protection grill.

The protection grilles prevent access to hazardous parts in the unit by unauthorized personnel.



#### CCCA - copper / aluminium condenser coils with acrylic lining

The package heat exchanger finned coils in copper /aluminium with acrylic covering can be used in places with concentrations in the air of saline and moderately aggressive agents.

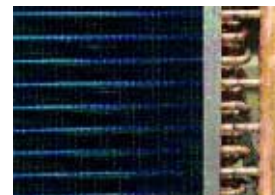

#### CCCC - copper / copper condenser coils

The package heat exchanger finned coils in copper /copper can be used in places with concentrations in the air of saline and highly aggressive agents.



#### CCCA1 - copper / aluminium condenser coils with Fin Guard (Silver) treatment

The packaged fin heat exchanger in copper and aluminium with Fin Guard Silver treatment can be used in locations where saline concentrations and other aggressive chemical agents are present in the air, keeping coil performance constant over time  
The special composition of the treatment allows excellent heat exchange.



#### AMMX - spring antivibration mounts

The spring anti-vibration devices reduce the vibration of the compressor during operation, and are attached to the feet of the base.

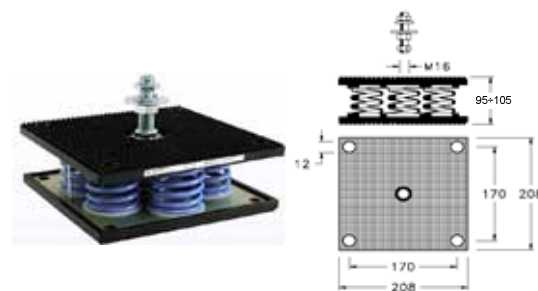

#### SDV - compressor discharge and suction shut-off valve

The intake valve, in conjunction with the one provided standard, makes it easier to service the compressor since it can be cut off completely. Losses of refrigerant and the time for emptying and filling the compress during servicing are substantially reduced.

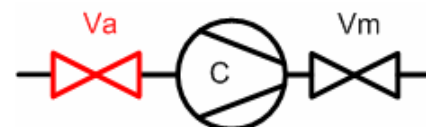

**SOUND LEVELS****Acoustic configuration: Standard (ST)**

Size	Sound Power Level (dB)								Sound pressure level	Sound power level
	Octave band (Hz)									
	63	125	250	500	1000	2000	4000	8000	dB(A)	dB(A)
2.160	85	92	93	96	96	94	88	87	80	100
2.180	85	92	93	96	96	94	88	87	80	100
2.190	88	94	95	96	96	94	91	93	81	101
2.200	89	95	96	96	96	94	93	94	81	102
2.240	90	96	96	96	97	95	93	95	81	102
2.280	90	96	96	97	97	94	94	95	81	102
2.300	89	95	95	99	96	96	95	95	82	103
2.320	88	92	93	100	95	97	95	94	82	103
2.340	89	93	94	100	95	98	96	94	82	104
2.360	90	94	94	101	96	98	97	95	83	104
2.440	92	96	97	102	98	100	98	97	84	106
2.480	96	100	105	103	102	99	92	88	84	106
2.540	96	100	106	104	103	100	92	89	85	107
2.600	96	100	106	104	103	100	92	88	85	107

Measures according to ISO 3744 regulations, with respect to the EUROVENT 8/1 certification.  
the sound levels refer to the unit at full load, in the rated test conditions.  
The sound pressure level refers to a distance of 1m from the external surface of the units operating in an open field.  
data referred to the following conditions :  
internal exchanger water = 12/7°C  
outdoor air temperature 35°C

**Acoustic configuration: compressors soundproofing (SC)**

Size	Sound Power Level (dB)								Sound pressure level	Sound power level
	Octave band (Hz)									
	63	125	250	500	1000	2000	4000	8000	dB(A)	dB(A)
2.160	82	89	90	93	93	92	85	85	77	98
2.180	82	89	90	93	93	92	85	85	77	98
2.190	85	91	92	93	94	92	89	90	78	99
2.200	86	92	93	93	93	91	90	91	78	99
2.240	87	93	93	94	94	92	90	92	79	99
2.280	87	93	93	94	94	91	91	92	79	99
2.300	86	92	92	96	93	93	92	92	79	100
2.320	86	90	90	97	92	94	92	91	79	100
2.340	86	90	91	97	92	95	93	91	79	101
2.360	87	91	92	98	93	95	94	92	80	102
2.440	89	94	95	100	95	97	95	94	81	103
2.480	93	97	102	100	99	96	89	85	81	103
2.540	93	97	103	101	100	98	89	86	82	104
2.600	93	97	103	101	100	97	89	85	82	104

**Acoustic configuration: Low noise (LN)**

Size	Sound Power Level (dB)								Sound pressure level	Sound power level
	Octave band (Hz)									
	63	125	250	500	1000	2000	4000	8000	dB(A)	dB(A)
2.160	87	90	97	92	89	85	73	67	74	94
2.180	87	90	97	92	89	85	74	67	74	94
2.190	90	94	100	93	90	86	78	75	75	96
2.200	91	94	101	93	89	86	79	77	75	96
2.240	91	94	101	93	90	86	79	77	75	96
2.280	91	95	101	94	90	86	80	78	76	97
2.300	91	94	100	96	90	88	81	78	76	91
2.320	90	92	98	97	88	89	82	77	76	97
2.340	91	93	99	97	89	90	83	78	76	98
2.360	92	94	100	98	90	91	84	79	77	99
2.440	93	95	102	99	91	91	84	79	78	100
2.480	94	96	108	97	92	89	76	68	79	101
2.540	94	96	108	97	92	89	76	67	79	101

**HYDRONIC**  
2.160 - 2.600**Acoustic configuration: Standard (ST) / Compressors insulation (SC)****GENERAL TECHNICAL SPECIFICATIONS**

Size		2.160	2.180	2.190	2.200	2.240	2.280	2.300	2.320	2.340	2.360	2.440	2.480	2.540	2.600	
<b>COOLING</b>																
Cooling capacity	1	kW	400	456	505	556	616	699	767	835	882	935	1016	1138	1272	1411
Compressor power input		kW	112	129	142	159	175	202	224	245	258	274	295	333	369	413
Total power input	2	kW	129	146	162	179	198	225	247	268	284	300	328	366	408	452
Heating capacity total recovery		kW	514	586	637	701	775	872	953	1027	1074	1155	1258	1404	1574	1732
Heating capacity partial recovery		kW	102	117	129	143	158	180	198	216	228	242	262	294	328	365
EER			3.1	3.12	3.12	3.11	3.11	3.11	3.11	3.12	3.11	3.12	3.1	3.11	3.12	3.12
ESEER			3.55	3.45	3.61	3.65	3.64	3.72	3.72	3.79	3.79	3.83	3.67	3.74	3.73	3.77
<b>COMPRESSOR</b>																
Type of compressors	3		DSW	DSW	DSW	DSW	DSW	DSW	DSW	DSW	DSW	DSW	DSW	DSW	DSW	DSW
No. of Compressors		Nr	2	2	2	2	2	2	2	2	2	2	2	2	2	2
Std Capacity control steps		Nr	STEPLESS	STEPLESS	STEPLESS	STEPLESS	STEPLESS	STEPLESS	STEPLESS	STEPLESS	STEPLESS	STEPLESS	STEPLESS	STEPLESS	STEPLESS	STEPLESS
Refrigerant circuits		Nr	2	2	2	2	2	2	2	2	2	2	2	2	2	2
<b>INTERNAL EXCHANGER</b>																
Type of internal exchanger	4		S&T	S&T	S&T	S&T	S&T	S&T	S&T	S&T	S&T	S&T	S&T	S&T	S&T	S&T
No. of internal exchangers		Nr	1	1	1	1	1	1	1	1	1	1	1	1	1	1
Water flow rate (Internal Exchanger)		l/s	19.1	21.8	24.1	26.6	29.4	33.4	36.6	39.9	42.1	44.7	48.5	54.4	60.8	67.4
Internal exchanger pressure drop		kPa	59	56	75	76	67	56	73	84	73	76	53	69	83	107
Water content		l	164.4	159.3	152.7	263.3	255.7	248.3	241.2	241.2	233.3	409.6	400.9	391.9	461.8	451.4
<b>EXTERNAL SECTION FANS</b>																
Type of fans	5		AX	AX	AX	AX	AX	AX	AX	AX	AX	AX	AX	AX	AX	AX
Number of fans		Nr	10	10	12	12	14	14	14	14	16	16	20	20	24	24
Standard air flow		l/s	55480	55480	61250	61250	71730	71730	71730	71730	81340	81340	101540	101540	122500	122500
<b>CONNECTIONS</b>																
Water fittings			141.3	141.3	141.3	168.3	168.3	168.3	168.3	168.3	168.3	219.1	219.1	219.1	219.1	219.1
<b>POWER SUPPLY</b>																
Standard power supply		V	400/3/50	400/3/50	400/3/50	400/3/50	400/3/50	400/3/50	400/3/50	400/3/50	400/3/50	400/3/50	400/3/50	400/3/50	400/3/50	400/3/50

(1) data referred to the following conditions :

internal exchanger water = 12/7°C

external exchanger air intake 35°C

(2) According to EUROVENT the Total Power Input does not consider the pump share, required to overcome the pressure drop for the solution circulation inside the exchangers.

(3) DSW = twin-screw compressor

(4) S&amp;T = tube bundle

(5) AX = axial-flow fan

**Acoustic configuration: Standard (ST) / Voltage: 400/3/50****ELECTRICAL DATA**

Size		2.160	2.180	2.190	2.200	2.240	2.280	2.300	2.320	2.340	2.360	2.440	2.480	2.540	2.600	
<b>F.L.A. - FULL LOAD CURRENT AT MAX ADMISSIBLE CONDITIONS</b>																
F.L.A. - Total		A	304.1	332.7	367.1	393.3	438.9	488.5	520.8	553.1	593.1	624.9	722.3	829.9	921.3	1031.5
<b>F.L.I. FULL LOAD POWER INPUT AT MAX ADMISSIBLE CONDITION</b>																
F.L.I. - Total		kW	176	195	217.4	236	262.2	295.4	320.1	344.8	367.7	386.8	439.7	480.6	540	607.2
<b>M.I.C. MAXIMUM INRUSH CURRENT</b>																
M.I.C. - Value		A	717.2	731.5	572.6	598.8	678.6	703.4	716.4	748.7	845.8	877.6	1096.3	1431.1	1690.8	1745.9

The F.L.A. data is to be considered in order to correctly size the supply line, whereas the M.I.C. data is used for the sizing of the protection device up the line.

voltage unbalance: max 2 %

power supply: 400/3/50 Hz +/-6%

**Acoustic configuration: Standard (ST) / Compressors insulation (SC)****OPERATING LIMITS (COOLING)**

Size		2.160	2.180	2.190	2.200	2.240	2.280	2.300	2.320	2.340	2.360	2.440	2.480	2.540	2.600
<b>EXTERNAL EXCHANGER</b>															
Max air intake temperature	1	°C	48	47	46	46	46	46	46	46	46	46	46	46	46
Max air intake temperature	2	°C	53	52	51	51	51	51	51	51	51	51	51	51	51
Min. air intake temperature	3	°C	-10	-10	-10	-10	-10	-10	-10	-10	-10	-10	-10	-10	-10
Min. air intake temperature	4	°C	-7	-7	-7	-7	-7	-7	-7	-7	-7	-7	-7	-7	-7
Min. air intake temperature	5	°C	2	2	2	2	2	2	2	2	2	2	2	2	2
Min. air intake temperature	6	°C	11	11	11	11	11	11	11	11	11	11	11	11	11
<b>INTERNAL EXCHANGER</b>															
Max water inlet temperature	7	°C	21	21	21	21	21	21	21	21	21	21	21	21	21
Min. water outlet temperature	8	°C	5	5	5	5	5	5	5	5	5	5	5	5	5
Min. water outlet temperature	9	°C	-8	-8	-8	-8	-8	-8	-8	-8	-8	-8	-8	-8	-8

(1) unit at full load; internal exchanger water 12/7°C

(2) capacity-controlled unit (automatic capacity control)

(3) unit at full load

external exchanger air in quiet

(4) capacity-controlled unit (automatic capacity control)

external exchanger air in quiet

(5) capacity-controlled unit (automatic capacity control)

air to external exchanger = 0.5m/sec

(6) capacity-controlled unit (automatic capacity control)

external exchanger air = 1m/sec

(7) external exchanger air intake 35°C

(8) Standard Version

external exchanger air intake 35°C

(9) Low temperature version

external exchanger air intake 35°C

Fluid with ethylene glycol of 40%

## ACOUSTIC CONFIGURATION: STANDARD (ST) / COMPRESSORS INSULATION (SC)

## COOLING PERFORMANCE

Size	To (°C)	EXTERNAL EXCHANGER AIR INTAKE TEMPERATURE (°C)													
		25		30		32		35		40		43		46	
		kWf	kWe	kWf	kWe	kWf	kWe	kWf	kWe	kWf	kWe	kWf	kWe	kWf	kWe
2.160	5	401.3	90.9	390.0	99.6	384.9	103.5	376.4	109.8	360.4	121.5	349.7	129.3	338.1	137.7
	6	413.6	91.9	402.1	100.7	396.8	104.6	388.2	111.0	371.8	122.8	360.8	130.6	348.9	139.0
	7	426.1	93.1	414.4	101.8	409.0	105.8	400.1	112.2	383.4	124.0	372.2	131.9	360.0	140.4
	8	438.9	94.3	426.9	103.1	421.4	107.0	412.3	113.4	395.2	125.3	383.7	133.3	371.3	141.8
	9	451.8	95.7	439.6	104.4	433.9	108.3	424.7	114.7	407.3	126.7	395.5	134.6	382.9	143.2
	10	465.0	97.1	452.4	105.7	446.7	109.6	437.3	116.0	419.5	128.0	407.6	136.0	394.7	144.7
2.180	5	458.8	104.4	445.4	114.3	439.3	118.8	429.2	126.1	410.2	139.7	397.5	148.7	383.8	158.3
	6	473.8	105.8	459.5	115.8	453.0	120.3	442.5	127.6	423.0	141.2	410.0	150.3	396.1	160.0
	7	488.3	107.2	473.5	117.2	466.8	121.7	456.0	129.0	436.0	142.7	422.7	151.9	408.5	161.6
	8	502.4	108.6	487.4	118.6	480.6	123.2	469.7	130.5	449.2	144.3	435.6	153.5	421.1	163.3
	9	516.0	110.0	501.3	120.1	494.6	124.6	483.5	132.0	462.7	145.8	448.8	155.1	433.7	165.0
	10	529.1	111.5	515.1	121.5	508.5	126.1	497.6	133.5	476.5	147.4	462.1	156.7	446.5	166.7
2.190	5	510.1	114.8	494.2	125.8	487.0	130.7	475.4	138.6	453.8	153.2	439.4	162.9	424.0	173.2
	6	525.0	116.3	508.9	127.3	501.6	132.2	489.7	140.2	467.6	154.9	453.0	164.6	437.2	175.0
	7	540.8	117.8	524.2	128.9	516.8	133.8	504.7	141.8	482.1	156.6	467.1	166.4	450.9	176.9
	8	557.3	119.4	540.4	130.5	532.7	135.5	520.3	143.5	497.1	158.4	481.7	168.3	465.2	178.8
	9	574.6	121.1	557.2	132.2	549.3	137.2	536.6	145.3	512.7	160.3	496.9	170.2	479.8	180.8
	10	592.6	122.8	574.8	134.0	566.7	139.0	553.5	147.1	529.0	162.1	512.6	172.1	495.0	182.8
2.200	5	563.5	128.5	544.8	140.9	536.4	146.4	522.8	155.1	497.7	171.3	481.0	181.8	463.3	193.1
	6	580.9	130.2	561.7	142.7	553.1	148.2	539.2	157.0	513.4	173.3	496.4	184.0	478.1	195.3
	7	598.6	132.0	578.9	144.5	570.1	150.1	555.9	159.0	529.5	175.4	511.9	186.1	493.2	197.6
	8	616.5	133.8	596.4	146.4	587.4	152.0	572.8	161.0	545.7	177.5	527.8	188.3	508.6	199.9
	9	634.8	135.7	614.2	148.4	604.9	154.0	590.0	163.0	562.2	179.6	543.9	190.5	524.2	202.1
	10	653.3	137.7	632.2	150.4	622.7	156.1	607.4	165.2	579.0	181.8	560.3	192.8	540.2	204.4
2.240	5	626.1	141.4	604.9	155.1	595.5	161.2	580.3	170.9	552.1	188.8	533.5	200.4	513.7	212.9
	6	644.9	143.3	623.2	157.1	613.6	163.2	598.0	173.0	569.2	191.0	550.3	202.7	530.0	215.3
	7	664.3	145.3	642.1	159.2	632.3	165.4	616.3	175.2	586.9	193.3	567.5	205.2	546.8	217.8
	8	684.3	147.4	661.7	161.4	651.5	167.6	635.3	177.5	605.1	195.7	585.3	207.7	564.1	220.4
	9	705.0	149.5	681.8	163.7	671.4	169.9	654.7	179.9	623.9	198.3	603.6	210.3		
	10	726.2	151.8	702.5	166.0	691.9	172.3	674.8	182.4	643.2	200.9	622.4	213.0		
2.280	5	713.3	162.3	687.6	178.2	676.3	185.2	658.1	196.3	624.7	216.6	602.7	229.9	579.4	243.9
	6	735.0	164.6	708.6	180.7	696.9	187.7	678.3	198.9	644.0	219.4	621.5	232.7	597.6	246.8
	7	756.7	167.0	729.8	183.2	717.8	190.3	698.7	201.6	663.6	222.2	640.6	235.6	616.1	249.8
	8	778.5	169.4	751.1	185.7	739.0	192.9	719.4	204.3	683.5	225.0	659.9	238.5	634.7	252.8
	9	800.4	171.9	772.7	188.3	760.3	195.5	740.4	207.0	703.6	227.9	679.4	241.5	653.6	255.9
	10	822.3	174.5	794.4	191.0	781.9	198.2	761.7	209.8	724.1	230.8	699.2	244.5	672.6	259.1
2.300	5	783.6	180.3	755.4	198.2	742.9	206.0	722.8	218.4	685.7	241.1	661.3	255.8	635.3	271.4
	6	807.2	182.9	778.4	200.9	765.6	208.8	745.0	221.3	706.9	244.2	681.8	259.0	655.1	274.7
	7	831.4	185.4	801.8	203.7	788.6	211.6	767.4	224.3	728.3	247.3	702.6	262.3	675.1	278.1
	8	856.0	188.0	825.4	206.4	811.9	214.5	790.1	227.3	749.9	250.5	723.5	265.5	695.4	281.4
	9	881.1	190.6	849.4	209.3	835.4	217.4	813.0	230.3	771.8	253.6	744.8	268.8	716.0	284.8
	10	906.6	193.2	873.7	212.1	859.3	220.3	836.1	233.3	793.8	256.8	766.2	272.1	736.9	288.2

kWf = Cooling capacity in kW  
kWe = Compressor power input in kW  
To = Internal exchanger water outlet temperature in° C  
DT = difference between inlet / outlet water temperature = 5°C

## ACOUSTIC CONFIGURATION: STANDARD (ST) / COMPRESSORS INSULATION (SC)

## COOLING PERFORMANCE

Size	To (°C)	EXTERNAL EXCHANGER AIR INTAKE TEMPERATURE (°C)													
		25		30		32		35		40		43		46	
		kWf	kWe	kWf	kWe	kWf	kWe	kWf	kWe	kWf	kWe	kWf	kWe	kWf	kWe
2.320	5	854.0	196.4	822.5	216.0	808.7	224.6	786.6	238.2	746.1	263.0	719.6	279.1	691.4	296.1
	6	879.7	199.1	847.5	219.0	833.3	227.7	810.6	241.5	769.1	266.5	741.8	282.7	712.9	299.9
	7	905.5	202.1	872.6	222.1	858.1	230.9	834.9	244.8	792.2	270.0	764.3	286.4	734.6	303.7
	8	931.4	205.2	897.9	225.4	883.1	234.2	859.3	248.1	815.6	273.6	786.9	290.1	756.4	307.5
	9	957.3	208.5	923.4	228.7	908.3	237.5	884.0	251.6	839.2	277.1	809.7	293.7	778.2	311.3
	10	983.3	211.9	948.9	232.1	933.6	240.9	908.8	255.0	863.0	280.7	832.6	297.4	800.2	315.2
2.340	5	901.9	207.2	868.9	227.7	854.2	236.7	830.7	251.2	787.4	277.8	758.9	295.3	728.5	313.8
	6	929.4	210.0	895.5	230.8	880.4	239.9	856.2	254.5	811.7	281.4	782.4	298.9	751.2	317.6
	7	957.3	213.0	922.5	233.9	907.1	243.1	882.2	257.9	836.5	284.9	806.4	302.6	774.3	321.4
	8	985.4	216.3	949.9	237.2	934.1	246.4	908.7	261.2	861.7	288.5	830.8	306.3	797.7	325.3
	9	1014	219.7	977.8	240.5	961.6	249.8	935.6	264.7	887.4	292.0	855.6	310.0	821.5	329.2
	10	1043	223.4	1006	244.0	989.6	253.2	963.0	268.1	913.6	295.6	880.8	313.8	845.6	333.2
2.360	5	957.8	219.9	922.4	241.7	906.7	251.3	881.4	266.7	834.7	294.8	803.9	313.2	771.1	332.8
	6	986.6	223.1	950.3	245.1	934.2	254.7	908.2	270.2	860.2	298.6	828.6	317.2	794.9	336.9
	7	1016	226.4	978.7	248.5	962.1	258.3	935.5	273.9	886.2	302.5	853.8	321.2	819.1	341.1
	8	1046	229.8	1007	252.1	990.5	261.9	963.1	277.7	912.6	306.5	879.3	325.4	843.8	345.4
	9	1076	233.3	1037	255.8	1019	265.7	991.2	281.5	939.4	310.6	905.3	329.6	868.9	349.7
	10	1107	236.8	1066	259.5	1049	269.5	1020	285.5	966.7	314.7	931.7	333.8		
2.440	5	1033	236.7	998.2	260.1	982.7	270.6	957.7	287.6	911.6	318.9	881.1	339.7	848.7	361.9
	6	1064	240.0	1028	263.6	1012	274.1	986.6	291.2	939.2	322.8	908.0	343.7	874.6	366.1
	7	1095	243.4	1058	267.1	1042	277.7	1016	294.9	967.1	326.7	935.0	347.8	900.8	370.3
	8	1126	246.8	1089	270.7	1072	281.4	1045	298.7	995.2	330.7	962.3	351.9	927.1	374.6
	9	1158	250.4	1119	274.4	1102	285.1	1075	302.5	1024	334.8	989.8	356.1	953.7	378.9
	10	1189	254.0	1150	278.1	1133	289.0	1105	306.4	1052	338.9	1018	360.3	980.5	383.3
2.480	5	1168	269.4	1122	295.0	1102	306.3	1071	324.4	1013	357.7	976.1	379.5	936.9	402.7
	6	1203	273.2	1157	299.1	1136	310.5	1104	328.8	1045	362.3	1007	384.3	966.5	407.7
	7	1240	277.1	1192	303.2	1171	314.7	1138	333.2	1077	367.0	1038	389.2	996.6	412.8
	8	1277	281.0	1228	307.4	1206	319.0	1172	337.6	1110	371.8	1070	394.2	1027	418.0
	9	1315	285.0	1265	311.6	1242	323.3	1207	342.1	1143	376.7	1102	399.3	1058	423.3
	10	1354	289.1	1302	315.9	1279	327.7	1243	346.7	1177	381.6	1135	404.4	1090	428.7
2.540	5	1305	297.4	1255	326.2	1233	338.8	1199	359.1	1135	396.3	1094	420.7	1050	446.6
	6	1344	301.7	1293	330.7	1270	343.5	1235	363.9	1170	401.4	1127	426.0	1083	452.1
	7	1384	306.2	1331	335.4	1308	348.3	1272	368.9	1205	406.7	1162	431.4	1116	457.7
	8	1424	310.7	1371	340.3	1347	353.3	1310	374.1	1242	412.2	1197	437.1	1150	463.5
	9	1465	315.4	1411	345.3	1387	358.4	1349	379.4	1279	417.8	1233	442.9	1185	469.5
	10	1507	320.3	1452	350.5	1428	363.8	1389	385.0	1317	423.6	1271	448.8	1221	475.6
2.600	5	1447	332.8	1392	365.0	1368	379.2	1330	402.0	1260	444.0	1215	471.5	1167	500.7
	6	1490	337.6	1434	370.1	1409	384.4	1370	407.4	1299	449.7	1252	477.4	1203	506.9
	7	1534	342.6	1477	375.4	1451	389.8	1411	413.0	1338	455.6	1290	483.5	1240	513.2
	8	1578	348.0	1520	380.9	1494	395.4	1453	418.7	1378	461.5	1329	489.6	1277	519.5
	9	1623	353.7	1564	386.6	1538	401.1	1496	424.5	1418	467.6	1368	495.8	1315	526.0
	10	1669	359.7	1608	392.5	1582	407.0	1539	430.5	1460	473.7	1408	502.1	1353	532.5

kWf = Cooling capacity in kW

kWe = Compressor power input in kW

To = Internal exchanger water outlet temperature in° C

DT = difference between inlet / outlet water temperature = 5°C

## Acoustic configuration: Low noise (LN)

## GENERAL TECHNICAL SPECIFICATIONS

Size		2.160	2.180	2.190	2.200	2.240	2.280	2.300	2.320	2.340	2.360	2.440	2.480	2.540	
<b>COOLING</b>															
Cooling capacity	1	kW	400	454	506	553	614	694	769	829	877	932	1020	1143	1287
Compressor power input		kW	116	131	146	159	180	206	227	247	256	274	304	338	383
Total power input	2	kW	129	146	162	177	198	224	247	267	281	299	329	368	413
Heating capacity total recovery		kW	514	586	637	701	775	872	953	1027	1074	1155	1258	1404	1574
Heating capacity partial recovery		kW	103	117	130	142	159	180	199	215	227	241	265	296	334
EER			3.1	3.11	3.12	3.12	3.1	3.1	3.11	3.1	3.12	3.12	3.1	3.11	3.12
ESEER			3.65	3.64	3.65	3.71	3.74	3.81	3.81	3.85	3.81	3.83	3.85	3.85	3.83
<b>COMPRESSOR</b>															
Type of compressors	3		DSW	DSW	DSW	DSW	DSW	DSW	DSW	DSW	DSW	DSW	DSW	DSW	DSW
No. of Compressors		Nr	2	2	2	2	2	2	2	2	2	2	2	2	2
Std Capacity control steps		Nr	STEPLESS	STEPLESS	STEPLESS	STEPLESS	STEPLESS	STEPLESS	STEPLESS	STEPLESS	STEPLESS	STEPLESS	STEPLESS	STEPLESS	STEPLESS
Refrigerant circuits		Nr	2	2	2	2	2	2	2	2	2	2	2	2	2
<b>INTERNAL EXCHANGER</b>															
Type of internal exchanger	4		S&T	S&T	S&T	S&T	S&T	S&T	S&T	S&T	S&T	S&T	S&T	S&T	S&T
No. of internal exchangers		Nr	1	1	1	1	1	1	1	1	1	1	1	1	1
Water flow rate (Internal Exchanger)		l/s	19.1	21.7	24.2	26.4	29.3	33.2	36.7	39.6	41.9	44.5	48.7	54.6	61.5
Internal exchanger pressure drop		kPa	59	56	75	75	67	55	73	83	72	75	53	69	85
Water content		l	164.4	159.3	152.7	263.3	255.7	248.3	241.2	241.2	233.3	409.6	400.9	391.9	461.8
<b>EXTERNAL SECTION FANS</b>															
Type of fans	5		AX	AX	AX	AX	AX	AX	AX	AX	AX	AX	AX	AX	AX
Number of fans		Nr	10	12	13	14	14	16	16	20	20	20	24	24	
Standard air flow		l/s	40520	45060	50500	52790	52790	52790	59180	59180	74630	74630	74630	90130	90130
<b>CONNECTIONS</b>															
Water fittings			141.3	141.3	141.3	168.3	168.3	168.3	168.3	168.3	168.3	219.1	219.1	219.1	219.1
<b>POWER SUPPLY</b>															
Standard power supply		V	400/3/50	400/3/50	400/3/50	400/3/50	400/3/50	400/3/50	400/3/50	400/3/50	400/3/50	400/3/50	400/3/50	400/3/50	400/3/50

(1) data referred to the following conditions :

internal exchanger water = 12/7°C

external exchanger air intake 35°C

(2) According to EUROVENT the Total Power Input does not consider the pump share, required to overcome the pressure drop for the solution circulation inside the exchangers.

(3) DSW = twin-screw compressor

(4) S&amp;T = tube bundle

(5) AX = axial-flow fan

## Acoustic configuration: Low noise (LN) / Voltage: 400/3/50

## ELECTRICAL DATA

Size		2.160	2.180	2.190	2.200	2.240	2.280	2.300	2.320	2.340	2.360	2.440	2.480	2.540	
<b>F.L.A. - FULL LOAD CURRENT AT MAX ADMISSIBLE CONDITIONS</b>															
F.L.A. - Total		A	286.1	319.3	347.8	376.3	413.7	463.3	500.2	532.5	573.5	605.3	686.3	803.1	878.1
<b>F.L.I. FULL LOAD POWER INPUT AT MAX ADMISSIBLE CONDITION</b>															
F.L.I. - Total		kW	169	190.4	210.2	230	252.4	285.6	312.7	337.4	361.3	380.4	425.7	471.4	523.2
<b>M.I.C. MAXIMUM INRUSH CURRENT</b>															
M.I.C. - Value		A	658.7	679.4	506.5	535	596.7	621.5	640.9	673.2	765	796.8	979.3	1326.9	1550.4

The F.L.A. data is to be considered in order to correctly size the supply line, whereas the M.I.C. data is used for the sizing of the protection device up the line.

voltage unbalance: max 2 %

power supply: 400/3/50 Hz +/-6%

## Acoustic configuration: Low noise (LN)

## OPERATING LIMITS (COOLING)

Size		2.160	2.180	2.190	2.200	2.240	2.280	2.300	2.320	2.340	2.360	2.440	2.480	2.540	
<b>EXTERNAL EXCHANGER</b>															
Max air intake temperature	1	°C	46	46	46	46	45	45	44	44	44	44	44	44	44
Max air intake temperature	2	°C	51	51	51	51	50	50	49	49	49	49	49	49	49
Min. air intake temperature	3	°C	-10	-10	-10	-10	-10	-10	-10	-10	-10	-10	-10	-10	-10
Min. air intake temperature	4	°C	-7	-7	-7	-7	-7	-7	-7	-7	-7	-7	-7	-7	-7
Min. air intake temperature	5	°C	2	2	2	2	2	2	2	2	2	2	2	2	2
Min. air intake temperature	6	°C	11	11	11	11	11	11	11	11	11	11	11	11	11
<b>INTERNAL EXCHANGER</b>															
Max water inlet temperature	7	°C	21	21	21	21	21	21	21	21	21	21	21	21	21
Min. water outlet temperature	8	°C	5	5	5	5	5	5	5	5	5	5	5	5	5
Min. water outlet temperature	9	°C	-8	-8	-8	-8	-8	-8	-8	-8	-8	-8	-8	-8	-8

(1) unit at full load; internal exchanger water 12/7°C

(2) capacity-controlled unit (automatic capacity control)

(3) unit at full load

external exchanger air in quiet

(4) capacity-controlled unit (automatic capacity control)

external exchanger air in quiet

(5) capacity-controlled unit (automatic capacity control)

air to external exchanger = 0.5m/sec

(6) capacity-controlled unit (automatic capacity control)

external exchanger air = 1m/sec

(7) external exchanger air intake 35°C

(8) Standard Version

external exchanger air intake 35°C

(9) Low temperature version

external exchanger air intake 35°C

Fluid with ethylene glycol of 40%

## ACOUSTIC CONFIGURATION: LOW NOISE (LN)

## COOLING PERFORMANCE

Size	To (°C)	EXTERNAL EXCHANGER AIR INTAKE TEMPERATURE (°C)													
		25		30		32		35		40		43		46	
		kWf	kWe	kWf	kWe	kWf	kWe	kWf	kWe	kWf	kWe	kWf	kWe	kWf	kWe
2.160	5	404.4	93.6	391.8	102.9	386.2	107.0	377.0	113.6	359.9	125.7	348.5	133.7	336.3	142.1
	6	416.7	94.8	403.8	104.2	398.0	108.3	388.6	114.9	371.1	127.1	359.5	135.1	347.0	143.6
	7	429.2	96.1	416.0	105.5	410.1	109.6	400.5	116.3	382.5	128.5	370.6	136.6	357.8	145.1
	8	442.0	97.4	428.5	106.8	422.4	111.0	412.5	117.7	394.1	130.0	382.0	138.1	368.9	146.7
	9	454.9	98.7	441.1	108.2	434.8	112.4	424.7	119.1	405.9	131.6	393.5	139.7	380.1	148.4
	10	468.0	100.0	453.9	109.6	447.5	113.8	437.2	120.6	417.9	133.1	405.2	141.4	391.6	150.1
2.180	5	459.2	105.3	444.6	115.7	438.1	120.3	427.4	127.8	407.5	141.5	394.3	150.5	380.2	160.2
	6	472.9	106.7	458.1	117.2	451.5	121.8	440.6	129.3	420.3	143.1	406.7	152.2	392.2	162.0
	7	486.9	108.2	471.9	118.7	465.0	123.3	453.9	130.9	433.1	144.8	419.3	154.0	404.4	163.7
	8	501.3	109.7	485.8	120.2	478.8	124.9	467.4	132.5	446.1	146.5	431.8	155.7	416.6	165.6
	9	515.9	111.2	499.9	121.8	492.7	126.5	481.0	134.1	459.1	148.2	444.5	157.5	428.9	167.4
	10	530.9	112.8	514.3	123.4	506.8	128.1	494.7	135.8	472.2	149.9	457.3	159.3		
2.190	5	512.7	117.6	496.0	129.1	488.6	134.2	476.5	142.3	454.2	157.4	439.4	167.2	423.7	177.8
	6	527.6	119.1	510.7	130.7	503.1	135.8	490.8	144.0	468.0	159.2	452.9	169.1	436.8	179.7
	7	543.4	120.7	526.0	132.3	518.3	137.5	505.7	145.8	482.3	161.0	466.9	171.1	450.4	181.8
	8	559.9	122.4	542.1	134.1	534.1	139.3	521.2	147.6	497.3	163.0	481.4	173.1	464.4	183.8
	9	577.2	124.2	558.9	135.9	550.7	141.1	537.4	149.5	512.7	164.9	496.4	175.1	478.9	186.0
	10	595.2	126.0	576.3	137.8	567.9	143.0	554.2	151.4	528.7	167.0	511.9	177.2		
2.200	5	561.6	128.4	542.4	141.0	533.8	146.5	520.0	155.3	494.5	171.5	477.6	182.1	459.7	193.3
	6	578.8	130.2	559.1	142.9	550.3	148.4	536.2	157.3	510.0	173.6	492.7	184.3	474.3	195.6
	7	596.3	132.1	576.1	144.8	567.1	150.4	552.6	159.4	525.8	175.8	508.1	186.6	489.1	198.0
	8	614.1	134.0	593.5	146.7	584.2	152.4	569.4	161.4	541.8	178.0	523.6	188.8	504.2	200.4
	9	632.2	135.9	611.1	148.7	601.6	154.4	586.4	163.5	558.1	180.2	539.5	191.2		
	10	650.6	137.9	629.0	150.8	619.3	156.5	603.7	165.6	574.7	182.5	555.5	193.5		
2.240	5	626.2	144.8	603.8	159.0	593.9	165.3	577.8	175.4	548.1	193.8	528.5	205.9		
	6	645.1	146.8	622.3	161.1	612.1	167.5	595.7	177.6	565.4	196.2	545.4	208.3		
	7	664.6	148.9	641.2	163.4	630.8	169.7	614.0	179.9	583.1	198.7	562.7	210.9		
	8	684.5	151.1	660.6	165.6	649.9	172.1	632.8	182.4	601.1	201.2	580.3	213.6		
	9	705.0	153.3	680.5	168.0	669.6	174.5	652.1	184.9	619.6	203.9	598.2	216.3		
	10	726.1	155.7	701.0	170.5	689.8	177.0	671.8	187.5	638.5	206.7	616.6	219.2		
2.280	5	712.2	165.4	685.1	181.8	673.1	189.0	654.0	200.5	618.9	221.3	595.9	234.9		
	6	733.6	167.8	705.7	184.4	693.5	191.7	673.8	203.3	637.7	224.3	614.1	237.9		
	7	755.2	170.4	726.6	187.1	714.0	194.4	693.9	206.1	656.9	227.3	632.6	241.1		
	8	777.0	172.9	747.8	189.8	734.8	197.2	714.2	209.0	676.2	230.3	651.4	244.2		
	9	798.9	175.6	769.1	192.6	755.9	200.1	734.8	211.9	695.9	233.4	670.4	247.4		
	10	821.0	178.3	790.7	195.5	777.2	203.0	755.6	214.9	715.8	236.6	689.6	250.7		
2.300	5	789.8	181.6	759.3	200.1	745.9	208.2	724.4	220.9	684.9	244.0	659.1	258.9		
	6	813.5	184.7	782.6	203.0	768.9	211.0	746.9	223.7	706.4	246.9	679.7	262.0		
	7	837.2	187.8	805.8	205.9	791.8	213.9	769.2	226.7	727.5	250.2	700.0	265.5		
	8	861.0	191.1	828.7	209.1	814.3	217.1	791.2	229.9	748.3	253.7	720.0	269.3		
	9	884.9	194.4	851.5	212.4	836.7	220.4	812.8	233.4	768.8	257.5	739.8	273.4		
	10	908.8	197.9	874.2	215.8	858.8	223.9	834.2	237.0	788.9	261.5	759.2	277.8		

kWf = Cooling capacity in kW

kWe = Compressor power input in kW

To = Internal exchanger water outlet temperature in °C

DT = difference between inlet / outlet water temperature = 5°C

## ACOUSTIC CONFIGURATION: LOW NOISE (LN)

## COOLING PERFORMANCE

Size	To (°C)	EXTERNAL EXCHANGER AIR INTAKE TEMPERATURE (°C)													
		25		30		32		35		40		43		46	
		kWf	kWe	kWf	kWe	kWf	kWe	kWf	kWe	kWf	kWe	kWf	kWe	kWf	kWe
2.320	5	851.5	196.9	818.7	217.4	804.2	226.3	781.0	240.3	738.4	265.6	710.5	281.9		
	6	876.2	200.8	843.7	220.7	829.2	229.4	805.6	243.3	761.9	268.6	732.9	285.2		
	7	901.6	204.5	868.4	224.0	853.5	232.7	829.3	246.6	784.4	272.3	754.5	289.1		
	8	927.6	208.0	892.8	227.6	877.2	236.3	852.2	250.4	805.8	276.5	775.3	293.7		
	9	954.3	211.3	916.7	231.3	900.3	240.2	874.1	254.6	826.3	281.2	795.2	298.8		
	10	981.6	214.4	940.3	235.1	922.7	244.3	895.1	259.2	845.8	286.6	814.3	304.6		
2.340	5	899.0	204.7	865.2	225.2	850.3	234.2	826.6	248.5	783.0	274.7	754.6	291.8		
	6	925.7	208.0	890.8	228.8	875.5	237.9	851.3	252.3	807.1	278.3	778.4	295.1		
	7	953.1	211.2	917.1	232.3	901.4	241.5	876.5	255.9	831.3	282.0	802.0	298.9		
	8	981.0	214.3	944.2	235.6	928.0	244.9	902.4	259.5	855.7	286.0	825.4	303.1		
	9	1010	217.5	971.9	238.8	955.3	248.1	928.8	263.0	880.3	290.0				
	10	1039	220.5	1000	241.8	983.3	251.2	955.8	266.4	905.0	294.3				
2.360	5	958.4	219.9	921.2	242.1	904.8	251.7	878.5	267.1	830.5	295.1	799.1	313.3		
	6	988.0	222.6	949.7	245.1	932.8	254.9	905.7	270.5	856.0	298.9	823.5	317.3		
	7	1017	225.9	977.6	248.7	960.2	258.6	932.4	274.3	881.7	302.9	848.5	321.3		
	8	1046	229.8	1005	253.0	987.1	263.0	958.7	278.8	907.4	307.1	874.2	325.3		
	9	1075	234.2	1032	258.0	1013	268.1	984.5	283.8	933.2	311.6	900.4	329.2		
	10	1104	239.2	1058	263.6	1039	273.7	1010	289.3	959.1	316.3	927.3	333.1		
2.440	5	1042	242.4	1005	267.6	988.1	278.7	961.7	296.5	913.0	329.0	881.1	350.3		
	6	1073	246.1	1035	271.4	1018	282.5	990.4	300.4	940.4	333.1	907.6	354.6		
	7	1104	249.9	1065	275.1	1047	286.2	1020	304.1	968.2	337.2	934.5	358.9		
	8	1135	253.9	1095	278.7	1078	289.9	1049	307.8	996.5	341.1	961.6	363.2		
	9	1164	257.9	1126	282.4	1108	293.5	1080	311.4	1025	345.1	989.0	367.4		
	10	1193	262.1	1157	286.0	1139	297.0	1110	314.9	1055	348.9	1017	371.7		
2.480	5	1182	271.8	1132	298.2	1111	309.7	1077	328.1	1016	361.7	977.1	383.6		
	6	1217	276.0	1166	302.6	1145	314.3	1110	332.9	1047	366.8	1007	388.9		
	7	1253	280.2	1201	307.2	1179	319.0	1143	337.8	1079	372.1	1037	394.4		
	8	1291	284.5	1237	311.8	1214	323.8	1177	342.8	1111	377.4	1068	400.0		
	9	1329	289.0	1273	316.6	1249	328.6	1211	347.9	1143	382.9	1099	405.6		
	10	1369	293.5	1310	321.4	1285	333.6	1246	353.1	1175	388.4	1130	411.4		
2.540	5	1325	306.7	1272	336.9	1248	350.1	1211	371.2	1144	409.7	1100	434.8		
	6	1364	311.2	1310	342.0	1287	355.5	1249	376.9	1179	415.8	1134	441.2		
	7	1404	316.0	1350	347.2	1325	360.9	1287	382.5	1215	421.9	1169	447.4		
	8	1445	321.0	1389	352.5	1365	366.3	1325	388.1	1252	427.8	1204	453.6		
	9	1486	326.3	1430	357.9	1404	371.7	1364	393.7	1289	433.7	1239	459.7		
	10	1528	331.8	1470	363.4	1444	377.2	1403	399.3	1326	439.5	1275	465.7		

kWf = Cooling capacity in kW

kWe = Compressor power input in kW

To = Internal exchanger water outlet temperature in °C

DT = difference between inlet / outlet water temperature = 5°C

**HYDRONIC**  
 2.160 - 2.600

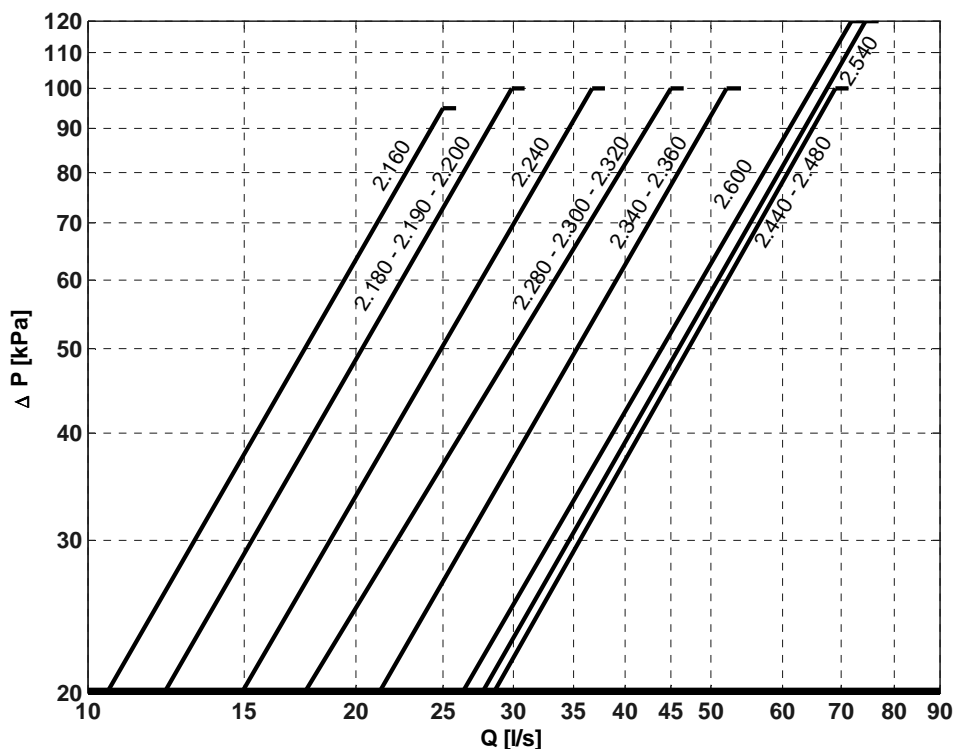
**INTERNAL EXCHANGER PRESSURE DROP**

	Qmin [l/s]	Qmax [l/s]
2.160	10.5	25.0
2.180	12.2	29.9
2.190	11.6	28.2
2.200	12.4	31.1
2.240	14.9	36.7
2.280	18.7	46.3
2.300	17.7	43.9
2.320	17.7	43.9
2.340	20.5	50.3
2.360	21.2	52.1
2.440	27.8	70.4
2.480	27.0	67.3
2.540	27.8	74.3
2.600	26.3	71.8

**OVERLOAD AND CONTROL DEVICE CALIBRATION**

		OPEN	CLOSED	VALUE
High pressure switch	kPa	1730	1170	-
Low pressure switch	kPa	70.0	170	-
Antifreeze protection	°C	3.00	5.50	-
High pressure safety valve	kPa	-	-	2700
Low pressure safety valve	kPa	-	-	1650
Max no. of compressor starts per hour	Nr	-	-	6.00
High compressor discharge temperature safety thermostat	°C	-	-	120

**CORRECTION FACTOR FOR ANTIFREEZE SOLUTIONS**

% ethylene glycol by weight		5%	10%	15%	20%	25%	30%	35%	40%
Freezing temperature	°C	-2.0	-3.9	-6.5	-8.9	-11.8	-15.6	-19.0	-23.4
Safety temperature	°C	3.0	1.0	-1.0	-4.0	-6.0	-10.0	-14.0	-19.0
Cooling Capacity Factor	Nr	0.995	0.990	0.985	0.981	0.977	0.974	0.971	0.968
Compressor input Factor	Nr	0.997	0.993	0.990	0.988	0.986	0.984	0.982	0.981
Internal exchanger Glycol solution flow Factor	Nr	1.003	1.010	1.020	1.033	1.050	1.072	1.095	1.124
Pressure drop Factor	Nr	1.029	1.060	1.090	1.118	1.149	1.182	1.211	1.243

The correction factors shown refer to water and glycol ethylene mixes used to prevent the formation of frost on the exchangers in the water circuit during inactivity in winter.

**FOULING CORRECTION FACTOR**

		INTERNAL EXCHANGER	
m <sup>2</sup> °C/W	F1		FK1
0.44 x 10 <sup>-4</sup> (-4)	1.00		1.00
0.88 x 10 <sup>-4</sup> (-4)	0.97		0.99
1.76 x 10 <sup>-4</sup> (-4)	0.94		0.98

F1 = Cooling capacity correction factors

FK2 = Compressors input power correction factors

**EXCHANGER OPERATING LIMITS**

		INTERNAL EXCHANGER	
		DPr (S - B)	DPw
		kPa	
CLIVET (C)	2450	2450	1050
PED (CE)	2450	2450	1050

DPr = Maximum operating pressure on refrigerant side

DPw = Maximum operating pressure on water side

**DIMENSIONAL DRAWING**

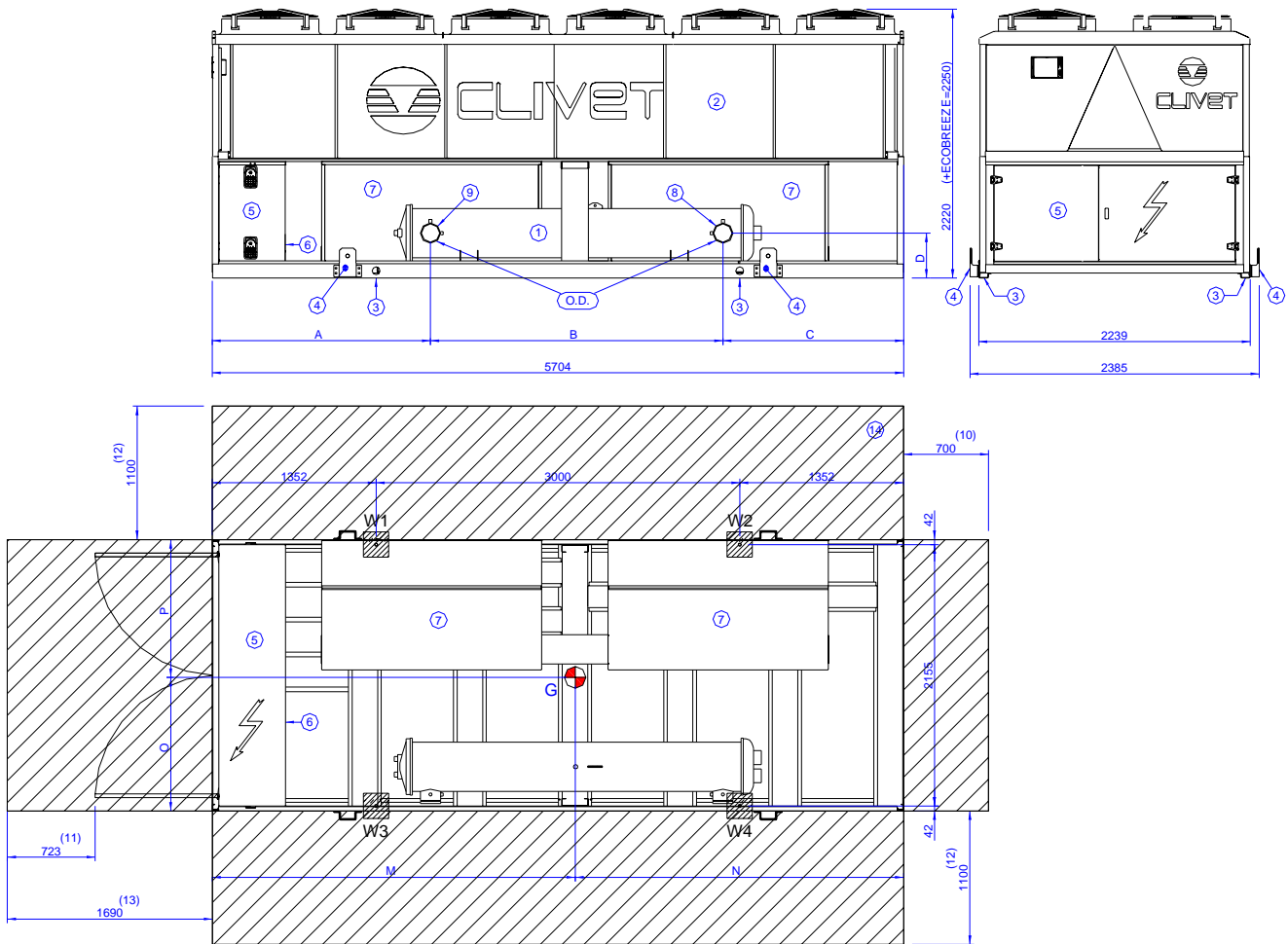

- (1) INTERNAL EXCHANGER (EVAPORATOR)
- (2) EXTERNAL EXCHANGER (CONDENSER)
- (3) HOLE TO HANG UNIT
- (4) LIFTING BRACKETS (REMOVABLE, IF REQUIRED, AFTER POSITIONING THE UNIT)
- (5) ELECTRICAL PANEL
- (6) POWER INPUT
- (7) SOUND PROOF ENCLOSURE ( ONLY IN THE EXPECTED VERSIONS)
- (8) INTERNAL EXCHANGER WATER INLET
- (9) INTERNAL EXCHANGER WATER OUTLET
- (10) MINIMUM DIMENSION FOR A SAFE PASSAGE.
- (11) MINIMUM DIMENSION FOR A SAFE PASSAGE WHEN THE DOOR OF THE ELECTRICAL SWITCHBOARD IS OPEN.
- (12) MINIMUM DIMENSION FOR A PROPER AIR FLOW TO THE CONDENSER COIL.
- IN THE CASE OF TWO UNITS SIDE BY SIDE THIS DISTANCE MUST BE DOUBLED
- (13) MINIMUM DIMENSION ON THE ELECTRICAL SWITCHBOARD SIDE.
- (14) CLEARANCE ACCESS RECOMMENDED
- (G) BARYCENTRE

Size	ST				SC				LN		
	2.160	2.180	2.190	2.200	2.160	2.180	2.190	2.200	2.160	2.180	
A	mm	2147	2147	2147	1800	2147	2147	2147	1800	2147	2147
B	mm	2450	2450	2450	2412	2450	2450	2450	2412	2450	2450
C	mm	1107	1107	1107	1492	1107	1107	1107	1492	1107	1107
D	mm	331	331	331	371	331	331	331	371	331	331
M	mm	2738	2739	2724	2763	2753	2754	2739	2772	2753	2756
N	mm	2966	2965	2980	2941	2951	2950	2965	2932	2951	2948
O	mm	1298	1300	1300	1267	1322	1324	1323	1290	1322	1319
P	mm	941	939	939	972	917	915	916	949	917	920
OD	mm	141.3	141.3	141.3	168.3	141.3	141.3	141.3	168.3	141.3	141.3
Length	mm	5704	5704	5704	5704	5704	5704	5704	5704	5704	5704
Depth	mm	2239	2239	2239	2239	2239	2239	2239	2239	2239	2239
Height	mm	2220	2220	2220	2220	2220	2220	2220	2220	2220	2220
W1	kg	1278	1284	1360	1419	1363	1370	1446	1504	1363	1399
W2	kg	1191	1198	1258	1342	1285	1291	1351	1435	1285	1320
W3	kg	1090	1094	1159	1242	1137	1140	1206	1289	1137	1169
W4	kg	1003	1007	1057	1166	1058	1062	1111	1220	1058	1091
Operating weight	kg	4563	4584	4834	5169	4843	4864	5114	5449	4843	4980
Shipping weight	kg	4399	4425	4682	4906	4679	4705	4962	5186	4679	4821

Particular accessories, executions or versions can bring about a great variation of the mass represented here. Please contact our Technical Department.

BT08F006GB-00

DIMENSIONAL DRAWING

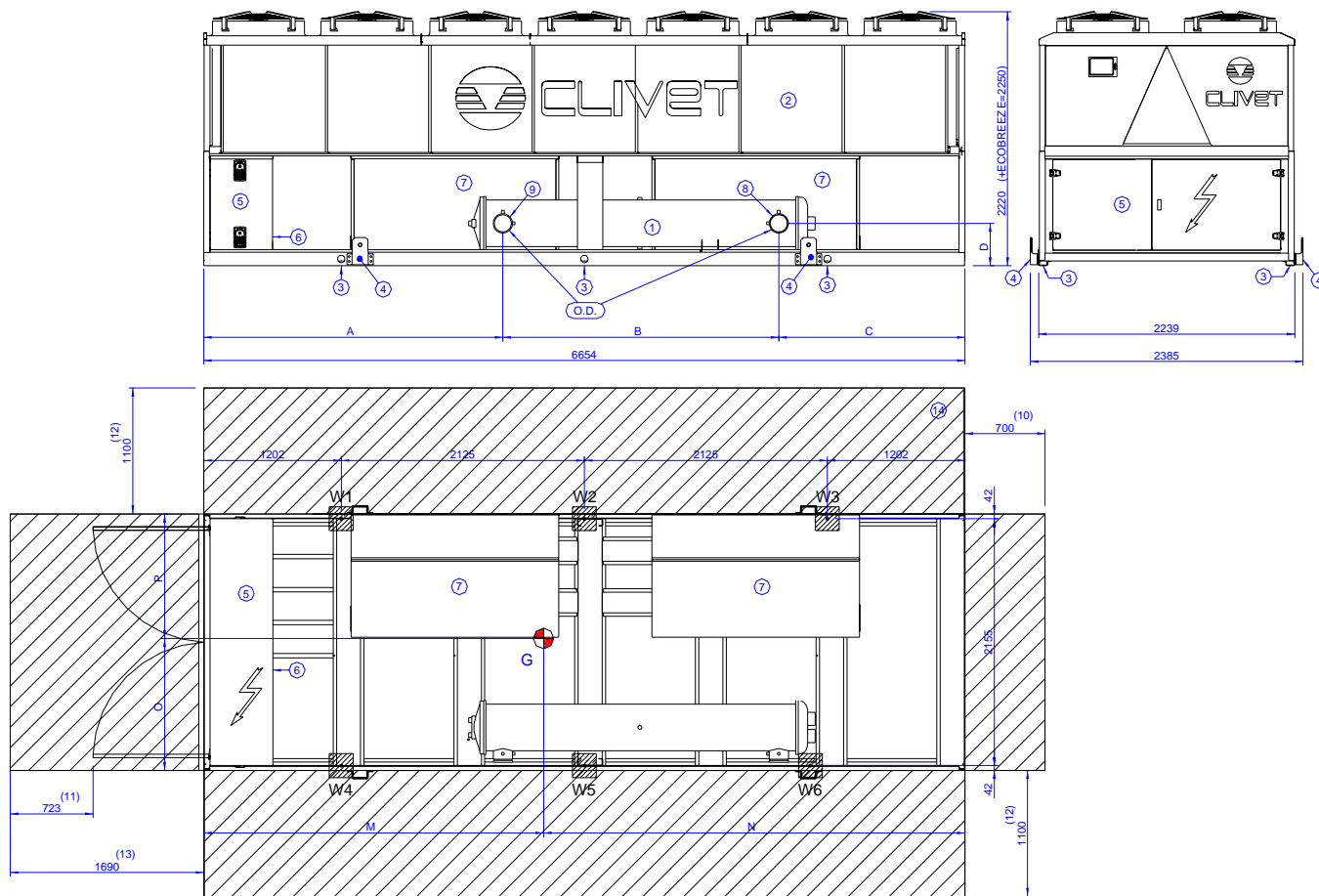

- (1) INTERNAL EXCHANGER (EVAPORATOR)
- (2) EXTERNAL EXCHANGER (CONDENSER)
- (3) HOLE TO HANG UNIT
- (4) LIFTING BRACKETS (REMOVABLE, IF REQUIRED, AFTER POSITIONING THE UNIT)
- (5) ELECTRICAL PANEL
- (6) POWER INPUT
- (7) SOUND PROOF ENCLOSURE ( ONLY IN THE EXPECTED VERSIONS)
- (8) INTERNAL EXCHANGER WATER INLET
- (9) INTERNAL EXCHANGER WATER OUTLET
- (10) MINIMUM DIMENSION FOR A SAFE PASSAGE.
- (11) MINIMUM DIMENSION FOR A SAFE PASSAGE WHEN THE DOOR OF THE ELECTRICAL SWITCHBOARD IS OPEN.
- (12) MINIMUM DIMENSION FOR A PROPER AIR FLOW TO THE CONDENSER COIL.  
IN THE CASE OF TWO UNITS SIDE BY SIDE THIS DISTANCE MUST BE DOUBLED
- (13) MINIMUM DIMENSION ON THE ELECTRICAL SWITCHBOARD SIDE.
- (14) CLEARANCE ACCESS RECOMMENDED
- (G) BARYCENTRE

Size		ST		SC		LN			
		2.240	2.280	2.240	2.280	2.190	2.200	2.240	2.280
A	mm	2615	2615	2615	2615	2600	2615	2615	2615
B	mm	2412	2412	2412	2412	2450	2412	2412	2412
C	mm	1627	1627	1627	1627	1604	1627	1627	1627
D	mm	371	371	371	371	331	371	371	371
M	mm	3274	3275	3291	3292	3238	3291	3293	3293
N	mm	3380	3379	3363	3362	3416	3363	3361	3361
O	mm	1207	1209	1243	1245	1266	1238	1238	1240
P	mm	1032	1030	996	994	973	1001	1001	999
OD	mm	168.3	168.3	168.3	168.3	141.3	168.3	168.3	168.3
Length	mm	6654	6654	6654	6654	6654	6654	6654	6654
Depth	mm	2239	2239	2239	2239	2239	2239	2239	2239
Height	mm	2220	2220	2220	2220	2220	2220	2220	2220
W1	kg	817	820	877	880	920	897	917	921
W2	kg	1204	1214	1353	1362	1241	1368	1390	1400
W3	kg	748	752	825	830	797	845	866	870
W4	kg	699	699	703	703	708	725	742	742
W5	kg	1030	1034	1085	1088	954	1106	1125	1128
W6	kg	640	641	661	663	613	683	701	702
Operating weight	kg	5138	5160	5504	5526	5233	5625	5741	5763
Shipping weight	kg	4883	4912	5249	5278	5080	5362	5486	5515

Particular accessories, executions or versions can bring about a great variation of the mass represented here. Please contact our Technical Department.

BT08F006GB-00

**DIMENSIONAL DRAWING**

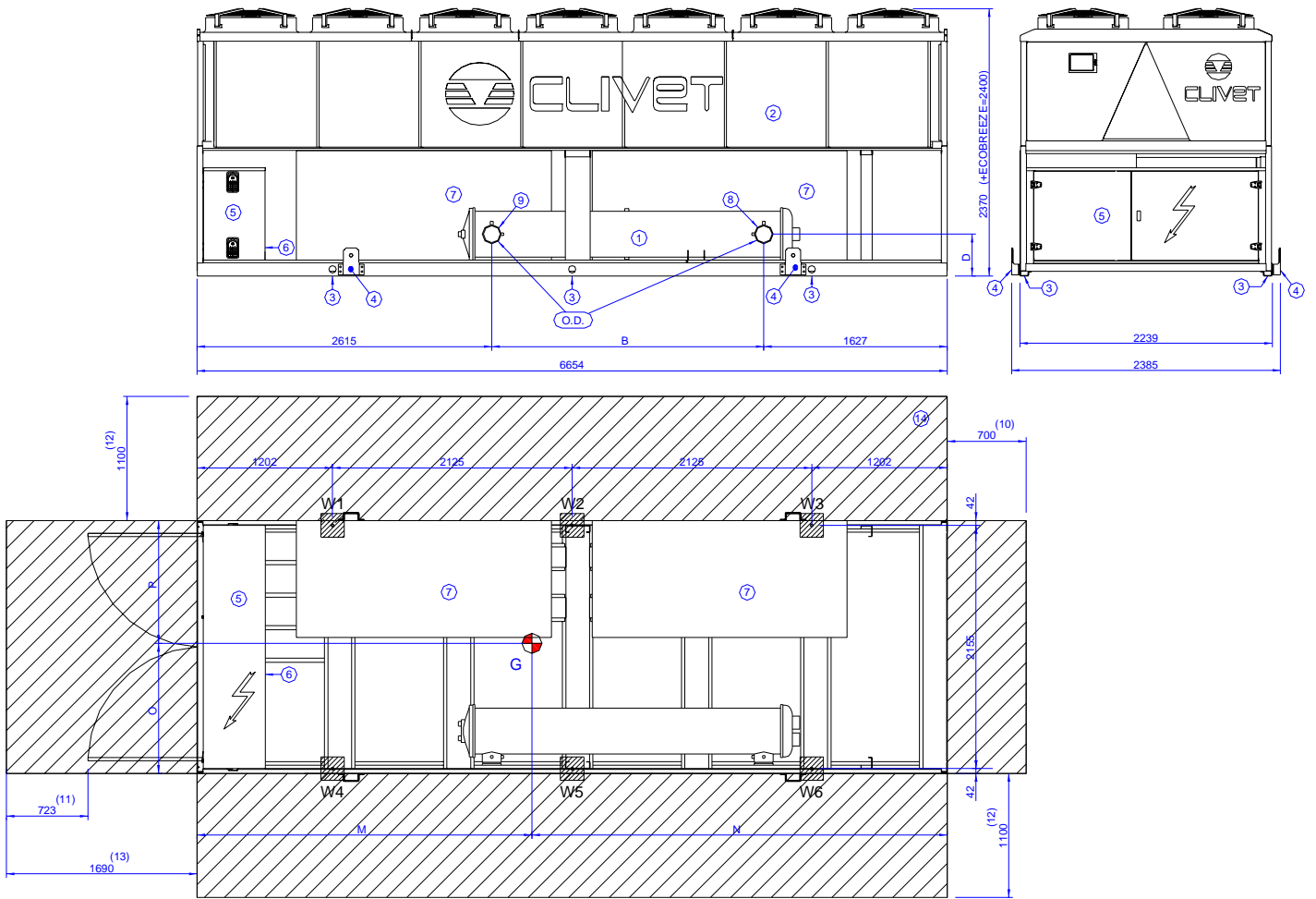

- (1) INTERNAL EXCHANGER (EVAPORATOR)
- (2) EXTERNAL EXCHANGER (CONDENSER)
- (3) HOLE TO HANG UNIT
- (4) LIFTING BRACKETS (REMOVABLE, IF REQUIRED, AFTER POSITIONING THE UNIT)
- (5) ELECTRICAL PANEL
- (6) POWER INPUT
- (7) SOUND PROOF ENCLOSURE ( ONLY IN THE EXPECTED VERSIONS)
- (8) INTERNAL EXCHANGER WATER INLET
- (9) INTERNAL EXCHANGER WATER OUTLET
- (10) MINIMUM DIMENSION FOR A SAFE PASSAGE.
- (11) MINIMUM DIMENSION FOR A SAFE PASSAGE WHEN THE DOOR OF THE ELECTRICAL SWITCHBOARD IS OPEN.
- (12) MINIMUM DIMENSION FOR A PROPER AIR FLOW TO THE CONDENSER COIL.  
IN THE CASE OF TWO UNITS SIDE BY SIDE THIS DISTANCE MUST BE DOUBLED
- (13) MINIMUM DIMENSION ON THE ELECTRICAL SWITCHBOARD SIDE.
- (14) CLEARANCE ACCESS RECOMMENDED
- (G) BARYCENTRE

Size		mm	ST		SC	
			2.300	2.320	2.300	2.320
A		mm	2615	2615	2615	2615
B		mm	2412	2412	2412	2412
C		mm	1627	1627	1627	1627
D		mm	371	371	371	371
M		mm	3114	3161	3126	3165
N		mm	3540	3493	3528	3489
O		mm	1202	1202	1237	1204
P		mm	1037	1037	1002	1035
OD		mm	168.3	168.3	168.3	168.3
Length		mm	6654	6654	6654	6654
Depth		mm	2239	2239	2239	2239
Height		mm	2370	2370	2370	2370
W1		kg	1079	1086	1151	1127
W2		kg	1103	1245	1248	1347
W3		kg	782	837	845	872
W4		kg	930	937	932	968
W5		kg	952	1074	1010	1158
W6		kg	674	723	684	750
Operating weight		kg	5520	5902	5870	6222
Shipping weight		kg	5279	5661	5629	5981

Particular accessories, executions or versions can bring about a great variation of the mass represented here. Please contact our Technical Department.

DIMENSIONAL DRAWING

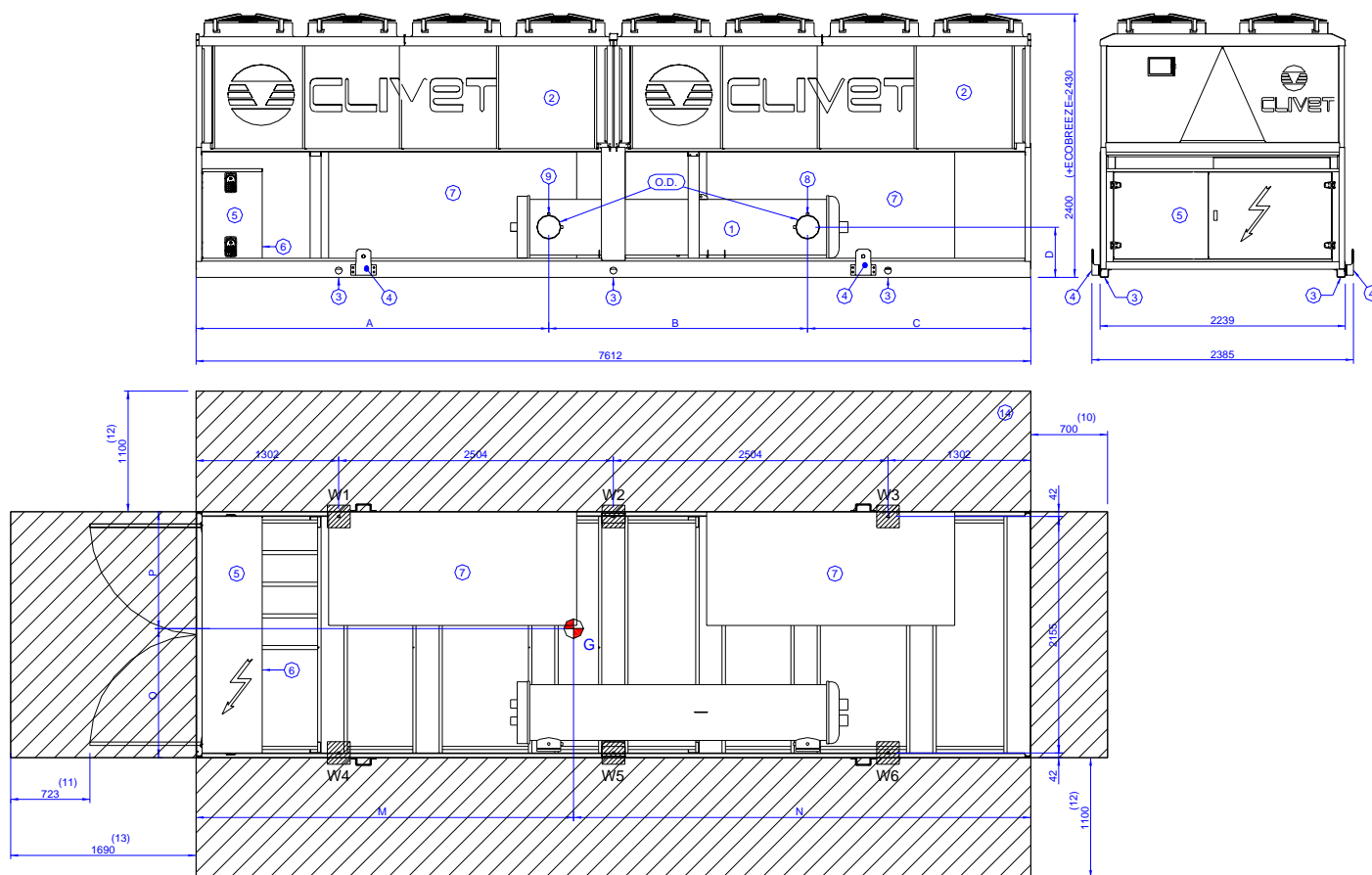

- (1) INTERNAL EXCHANGER (EVAPORATOR)
- (2) EXTERNAL EXCHANGER (CONDENSER)
- (3) HOLE TO HANG UNIT
- (4) LIFTING BRACKETS (REMOVABLE, IF REQUIRED, AFTER POSITIONING THE UNIT)
- (5) ELECTRICAL PANEL
- (6) POWER INPUT
- (7) SOUND PROOF ENCLOSURE ( ONLY IN THE EXPECTED VERSIONS)
- (8) INTERNAL EXCHANGER WATER INLET
- (9) INTERNAL EXCHANGER WATER OUTLET
- (10) MINIMUM DIMENSION FOR A SAFE PASSAGE.
- (11) MINIMUM DIMENSION FOR A SAFE PASSAGE WHEN THE DOOR OF THE ELECTRICAL SWITCHBOARD IS OPEN.
- (12) MINIMUM DIMENSION FOR A PROPER AIR FLOW TO THE CONDENSER COIL.  
IN THE CASE OF TWO UNITS SIDE BY SIDE THIS DISTANCE MUST BE DOUBLED
- (13) MINIMUM DIMENSION ON THE ELECTRICAL SWITCHBOARD SIDE.
- (14) CLEARANCE ACCESS RECOMMENDED
- (G) BARYCENTRE

Size			ST		SC		LN	
			2.340	2.360	2.340	2.360	2.300	2.320
A	mm		3012	3242	3012	3242	3012	3012
B	mm		2412	2360	2412	2360	2412	2412
C	mm		2188	2010	2188	2010	2188	2188
D	mm		400	457	400	457	400	400
M	mm		3755	3783	3774	3799	3699	3776
N	mm		3857	3829	3838	3813	3913	3836
O	mm		1192	1138	1215	1185	1199	1214
P	mm		1047	1101	1024	1054	1040	1025
OD	mm		168.3	219.1	168.3	219.1	168.3	168.3
Length	mm		7612	7612	7612	7612	7612	7612
Depth	mm		2239	2239	2239	2239	2239	2239
Height	mm		2400	2400	2400	2400	2400	2400
W1	kg		993	955	1066	998	1051	1082
W2	kg		1407	1541	1534	1797	1452	1545
W3	kg		925	924	1020	988	906	1039
W4	kg		873	924	898	888	912	913
W5	kg		1237	1491	1292	1599	1259	1304
W6	kg		813	894	859	879	785	876
Operating weight	kg		6249	6730	6669	7150	6366	6760
Shipping weight	kg		6016	6321	6436	6741	6125	6519

Particular accessories, executions or versions can bring about a great variation of the mass represented here. Please contact our Technical Department.

BT08F006GB-00

**DIMENSIONAL DRAWING**

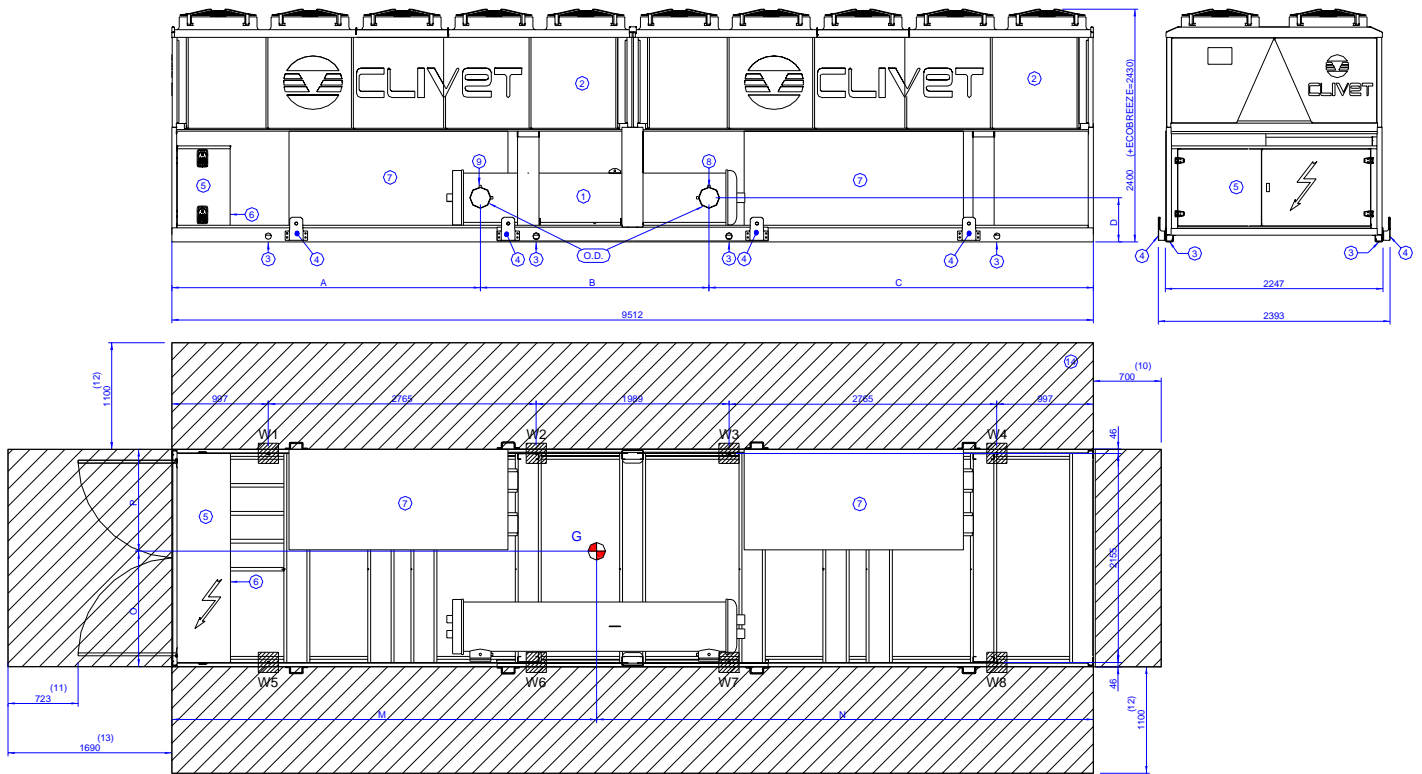

- (1) INTERNAL EXCHANGER (EVAPORATOR)
- (2) EXTERNAL EXCHANGER (CONDENSER)
- (3) HOLE TO HANG UNIT
- (4) LIFTING BRACKETS (REMOVABLE, IF REQUIRED, AFTER POSITIONING THE UNIT)
- (5) ELECTRICAL PANEL
- (6) POWER INPUT
- (7) SOUND PROOF ENCLOSURE ( ONLY IN THE EXPECTED VERSIONS)
- (8) INTERNAL EXCHANGER WATER INLET
- (9) INTERNAL EXCHANGER WATER OUTLET
- (10) MINIMUM DIMENSION FOR A SAFE PASSAGE.
- (11) MINIMUM DIMENSION FOR A SAFE PASSAGE WHEN THE DOOR OF THE ELECTRICAL SWITCHBOARD IS OPEN.
- (12) MINIMUM DIMENSION FOR A PROPER AIR FLOW TO THE CONDENSER COIL.
- IN THE CASE OF TWO UNITS SIDE BY SIDE THIS DISTANCE MUST BE DOUBLED
- (13) MINIMUM DIMENSION ON THE ELECTRICAL SWITCHBOARD SIDE.
- (14) CLEARANCE ACCESS RECOMMENDED
- (G) BARYCENTRE

Size	ST		SC		LN			
	2.440	2.480	2.440	2.480	2.340	2.360	2.440	
A	mm	3185	3185	3185	3185	2980	3185	3185
B	mm	2360	2360	2360	2360	2412	2360	2360
C	mm	3967	3967	3967	3967	4120	3967	3967
D	mm	457	457	457	457	400	457	457
M	mm	5061	5027	5050	4989	4850	5021	5010
N	mm	4451	4485	4462	4523	4662	4491	4502
O	mm	1169	1208	1049	1015	1426	1393	1395
P	mm	1078	1039	1198	1432	1021	1054	1052
OD	mm	219.1	219.1	219.1	219.1	168.3	219.1	219.1
Length	mm	9512	9512	9512	9512	9512	9512	9512
Depth	mm	2247	2247	2247	2247	2247	2247	2247
Height	mm	2400	2400	2400	2400	2400	2400	2400
W1	kg	783	948	858	1109	1004	919	975
W2	kg	1302	1475	1390	1690	1324	1497	1554
W3	kg	902	1082	986	1231	1022	1026	1083
W4	kg	848	1005	927	1144	962	966	1021
W5	kg	866	966	899	912	808	816	857
W6	kg	1441	1503	1455	1390	1066	1329	1366
W7	kg	645	733	669	692	605	607	646
W8	kg	607	680	629	643	570	572	610
Operating weight	kg	7394	8392	7814	8812	7362	7731	8112
Shipping weight	kg	6993	8000	7413	8420	7129	7322	7711

Particular accessories, executions or versions can bring about a great variation of the mass represented here. Please contact our Technical Department.

BT08F006GB-00

## DIMENSIONAL DRAWING

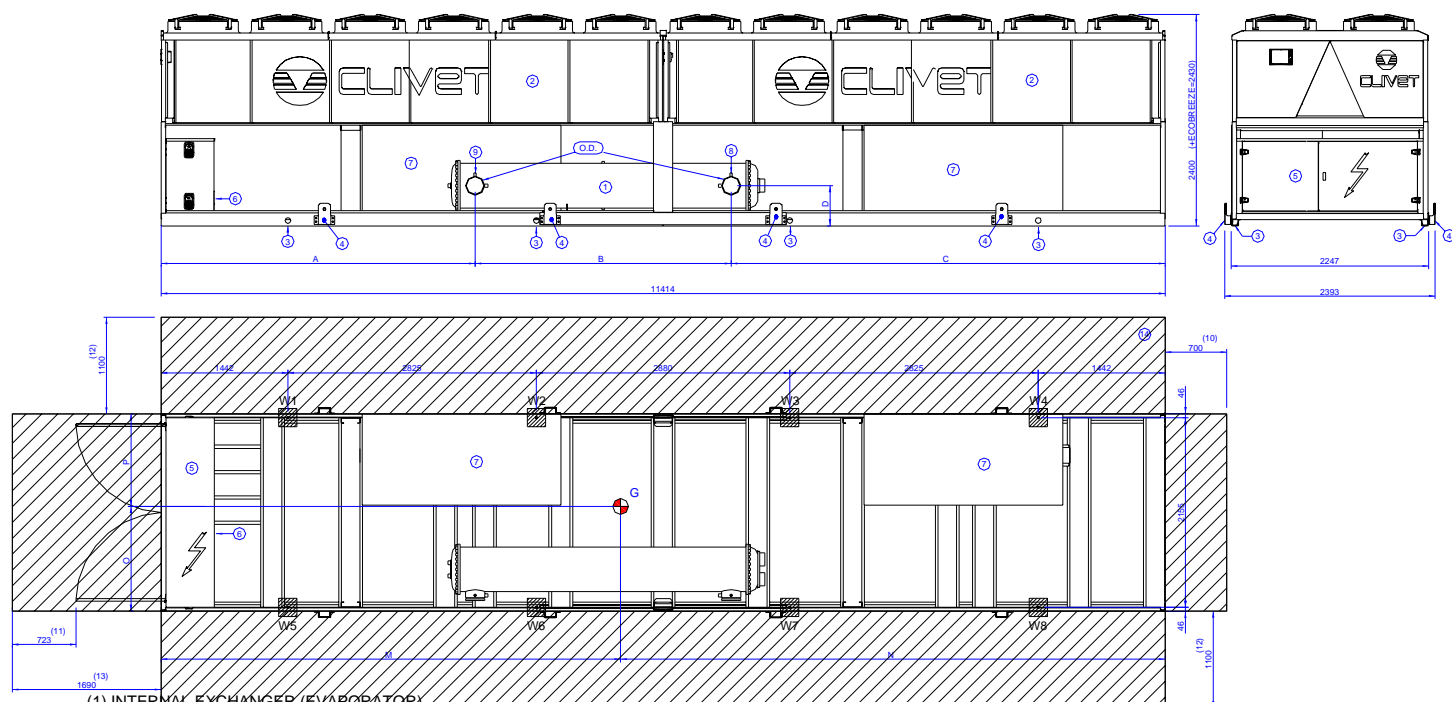

- (1) INTERNAL EXCHANGER (EVAPORATOR)  
 (2) EXTERNAL EXCHANGER (CONDENSER)  
 (3) HOLE TO HANG UNIT  
 (4) LIFTING BRACKETS (REMOVABLE, IF REQUIRED, AFTER POSITIONING THE UNIT)  
 (5) ELECTRICAL PANEL  
 (6) POWER INPUT  
 (7) SOUND PROOF ENCLOSURE ( ONLY IN THE EXPECTED VERSIONS)  
 (8) INTERNAL EXCHANGER WATER INLET  
 (9) INTERNAL EXCHANGER WATER OUTLET  
 (10) MINIMUM DIMENSION FOR A SAFE PASSAGE.  
 (11) MINIMUM DIMENSION FOR A SAFE PASSAGE WHEN THE DOOR OF THE ELECTRICAL SWITCHBOARD IS OPEN.  
 (12) MINIMUM DIMENSION FOR A PROPER AIR FLOW TO THE CONDENSER COIL.  
 IN THE CASE OF TWO UNITS SIDE BY SIDE THIS DISTANCE MUST BE DOUBLED  
 (13) MINIMUM DIMENSION ON THE ELECTRICAL SWITCHBOARD SIDE.  
 (14) CLEARANCE ACCESS RECOMMENDED  
 (G) BARYCENTRE

Size		ST		SC		LN	
		2.540	2.600	2.540	2.600	2.480	2.540
A	mm	3570	3570	3570	3570	4120	3570
B	mm	2910	2910	2910	2910	2360	2910
C	mm	4934	4934	4934	4934	4934	4934
D	mm	457	457	457	457	457	457
M	mm	6030	5921	6015	5943	5744	5937
N	mm	5384	5493	5399	5471	5670	5477
O	mm	1217	1417	1008	1008	1004	1012
P	mm	1030	1030	1439	1439	1443	1435
OD	mm	219.1	219.1	219.1	219.1	219.1	219.1
Length	mm	11414	11414	11414	11414	11414	11414
Depth	mm	2247	2247	2247	2247	2247	2247
Height	mm	2400	2400	2400	2400	2400	2400
W1	kg	1042	1252	1175	1297	1343	1291
W2	kg	1660	1807	1902	1907	1680	1887
W3	kg	1208	1410	1324	1458	1322	1450
W4	kg	1095	1152	1256	1250	1248	1231
W5	kg	1041	1048	953	1047	1058	1048
W6	kg	1658	1513	1543	1539	1324	1532
W7	kg	813	829	741	825	742	826
W8	kg	736	677	702	707	701	702
Operating weight	kg	9253	9687	9595	10029	9418	9967
Shipping weight	kg	8791	9236	9133	9578	9026	9505

Particular accessories, executions or versions can bring about a great variation of the mass represented here.  
 Please contact our Technical Department.

BT08F006GB-00

**HYDRONIC**  
2.160 - 2.600

BT08F006GB-00

BT08F006GB-00

**HYDRONIC**  
2.160 - 2.600

**CLIVET SPA**  
**Feltre (BL) ITALY**  
Tel. + 39 0439 3131  
Fax + 39 0439 313300  
info@clivet.it

**CLIVET ESPAÑA S.A.**  
**Madrid - SPAIN**  
Tel. + 34 91 6658280  
Fax + 34 91 6657806  
info@clivet.es

**CLIVET UK LTD**  
**Fareham (Hampshire) U.K.**  
Tel. + 44 (0) 1489 572238  
Fax + 44 (0) 1489 573033  
info@clivet-uk.co.uk

**CLIVET NEDERLAND B.V.**  
**Amersfoort - Netherlands**  
Tel. + 31 (0) 33 7503420  
Fax + 31 (0) 33 7503424  
info@clivet.nl

**CLIVET SPA**  
**BUREAU DE LIAISON EN FRANCE**  
**Verrières le Buisson - FRANCE**  
Tel. + 33 (0)1 69 20 25 75  
Fax + 33 (0)1 69 20 60 76  
info.fr@clivet.com

**CLIVET GmbH**  
**Norderstedt - GERMANY**  
Tel. +49 (0) 40 32 59 57-0  
Fax +49 (0) 40 32 59 57-194  
info.de@clivet.com

**CLIVET TFAIR SYSTEMS (P) LTD.**  
**Malur - INDIA**  
Tel. +91 8151 232683/5  
Fax +91-8151-232684  
info@clivettfa.com

The data contained in this bulletin is not binding and may be changed by the manufacturer without prior notice. All reproduction, even partial, is prohibited.  
© Copyright - CLIVET S.p.A. - Feltre (BL) - Italy