

SCREWLINE

WATER-COOLED LIQUID CHILLER AT HIGH EFFICIENCY
FOR INDOOR INSTALLATION

WDH-HE 2.220-2.600 SERIES

Nominal cooling capacity from 633 to 1711 kW



SCREWLINE WDH-HE is the innovative water-cooled liquid chiller at **high energy-efficiency**, equipped with **two double-screw compressors** with continuous capacity control and an optimised compression ratio, high-performance tube heat-exchanger and electronic expansion valve.

This proven dry-expansion technology enables a **reduced** ecological **refrigerant load** to be used, without any impact on the atmospheric ozone.

Its **very high efficiency at full load outstrips the performance of class A chillers**, which is added to its minimum consumption over the entire annual cycle, thanks to the high efficiency **also at part load**.

SCREWLINE WDH-HE is therefore, the ideal solution for ECBC or LEED certified buildings and for industrial applications looking for great reliability and a reduction in operating costs.

MORE EFFICIENCY, MORE VALUE

The innovative adopted technology exalts its efficiency both at **full load** and at **part load**, with an advantage of over 12% compared to Class A chillers.

The result is a further **reduction** of the **energy** required to condition the served building, thus an increase in its property value.

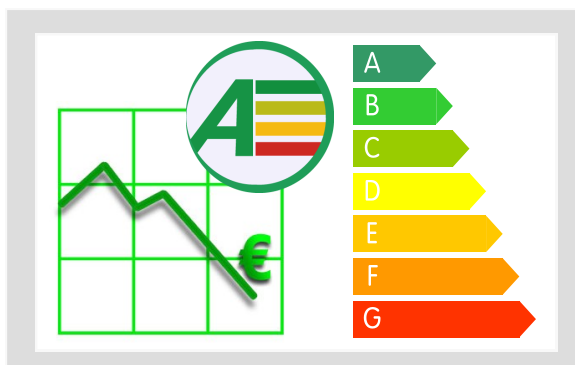

PERFECT FOR GREEN BUILDINGS

This very high efficiency responds to the most stringent requirements of **certification protocols** such as ECBC and LEED.

Its **refrigerant** is also eco-compatible, and its content is much lower compared to the most chillers on the market, in particular those with flooded evaporators, thus further increasing its certification credits.



SECURE TECHNOLOGY

Its excellent energy performance derives from the combination of:

- High performance **double-screw compressors** complete with an economising circuit, optimised to operate with maximum energy-efficiency at low compressor ratios. Equipped with continuous capacity control. Adopting two compressors enables further reliability, great working flexibility and low cold cranking amps.
- **Electronic expansion valve** which rapidly and precisely adapts to the effective load required by the user
- **Tube heat-evaporator**, optimised for refrigerant R134a and equipped with a patented refrigerant distributor able to inject the ideal quantity into each tube
- **Tube heat-exchanger (condenser)** with particular liquid circulation which reduces the temperature difference between the source and the refrigerant (approach), to the benefit of the overall efficiency



GREAT APPLICATIVE VERSATILITY

Suitable for different types of terminals, from **fan coils** to **radiant** and **chilled beams**, WDH-HE is also available with **low temperatures liquid** operating (Brine) for high dehumidification applications or **industrial processes**. Furthermore, it is ideal for **different heat sources** used in large-scale systems, such as cooling towers, dry coolers or well water.



INDEX OF THE TECHNICAL SECTION

▶ Standard unit specifications	Page 4
▶ General technical specifications - Electrical data	Page 5
▶ Operating limits (COOLING)	Page 6
▶ Sound levels	Page 6
▶ Cooling performances	Pages 7-8
▶ Pressure drops	
Internal exchanger (EVAPORATOR)	Page 9
External exchanger (CONDENSER) - WELL WATER Application	Page 9
External exchanger (CONDENSER) - TOWER WATER Application	Page 9
▶ Correction factor for antifreeze solutions	Page 10
▶ Exchanger operating limits	Page 10
▶ Overload and control device calibration	Page 10
▶ Versions	Page 11
▶ Accessories	Pages 11-14
▶ Option compatibility	Page 14
▶ Dimensional drawing	Page 15

CONFIGURATION CODE

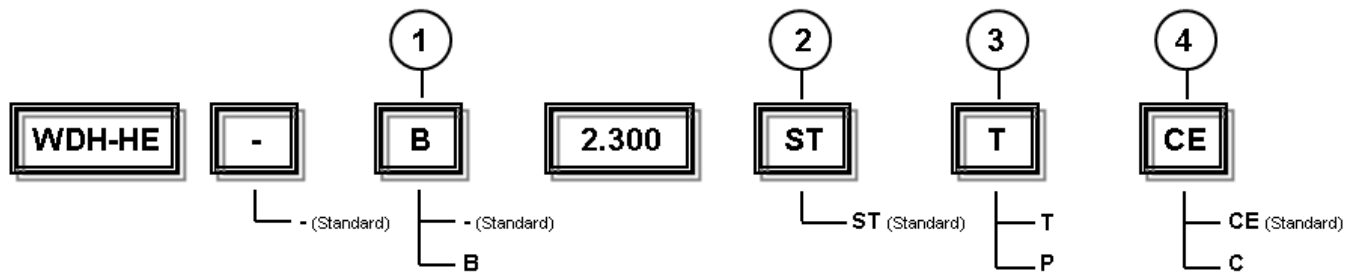

(1) LOW TEMPERATURE LIQUID
 Low temperature liquid: not required (-)
 standard
 Low temperature liquid (B)

(2) ACOUSTIC CONFIGURATION
 Standard acoustic configuration (ST)
 Standard

(3) APPLICATION
 Well water application(P)
 Tower water application(T)

(4) HEAT EXCHANGERS APPROVALS
 Heat exchangers certified CE = PED (according to European PED Directive) (PED)
 standard
 Heat exchangers approvals C = CLIVET (Internal Testing) (CLV)

STANDARD UNIT SPECIFICATIONS

COMPRESSOR

Semi hermetic twin screw compressors: the main screw (male, with five lobes) is driven directly by the electric motor, while the secondary screw (female with six vanes) is driven by the primary screw. Continuous regulation of the chilling capacity delivered with unloaded start-up. The seal is guaranteed by extremely accurate tolerances in the working of all the moving parts and by the specific circulation of oil between the screws. The free flow lubrication system resulting from pressure differences, is equipped with a separator, level indicator and oil filter. An oil heater prevents excessive dilution of the oil by the refrigerant, and is activated automatically at all stages where the compressor is switched off. . The electric motor is an asynchronous, two poles, reduced load start of the star delta type, suction gas cooled. Fully protected electronic module, with safety sensor for monitoring discharge temperature, sensors for monitoring maximum temperature of the windings, device to monitor the direction of rotation of the motor, device to monitor the absence of phase.

Cut-off valve on the discharge line of the refrigerant. Filter on the suction line, at the inlet to the compressor. Incorporated silencer and non return valve on the discharge of the compressor. Automatic internal safety valve between HP and LP.

EVAPORATOR

Direct expansion evaporator with refrigerant side independent circuit for each compressor. The evaporator is composed of a cover made of carbon steel. The ducts, anchored to the tube plate by mechanical expansion, are made of copper, high efficiency, internally rifled to improve thermal exchange and specially designed for use with modern ecological refrigerants. It also includes a water side protection differential switch, an anti-freeze heating element to protect against icing, and covering in closed-cell thermo-insulating material that prevents the formation of condensation and heat exchange with the exterior.

CONDENSER

Shell and tube condenser with cover side refrigerant and water in ducts. It is composed of a cover made of carbon steel. The integral finned ducts are made of copper, whereas the tube plates are made of carbon steel. They are provided with holes with grooves for the mechanical expansion of the ducts. The heads are removable to allow cleaning and maintenance of the condenser. The water connections are available for the connection with well water (P) or tower water (T). Specify use when ordering.

REFRIGERANT CIRCUIT

The units are made with two independent refrigerant circuits, each with:

- high safety pressure switch
- low safety pressure switch
- high and low pressure gauges
- high pressure safety valve
- low pressure safety valve
- replaceable anti-acid solid cartridge dehydrator filter
- electronic expansion valve (see details further on)
- refrigerant circuit with economizer
- sight glass with moisture indicator
- liquid line shut-off valve
- compressor discharge shut-off valve

ELECTRICAL PANEL

Electrical panel made from hot-galvanized and painted plate.

The power section includes:

- main door lock isolator switch
- compressor control contactor
- compressor fuses and thermal overload relay
- isolating transformer for auxiliary circuit power supply

The control section includes:

- proportional - integral water temperature control
- antifreeze protection
- compressor overload protection and timer
- self-diagnosis system with immediate display of the error code
- compressor operating hour display
- phase monitor

- remote ON/OFF control
- automatic rotation control of compressor start-up to balance wear (breakaway + hours of operation)
- relay for remote cumulative fault signal
- input for demand limit (absorbed power limit according to an external signal 0÷10V or 4÷20mA)
- high refrigerant gas pressure pre-alarm function that in many cases prevents the unit shut-down
- display of the set values, the error codes and the parameter index
- interface terminal with graphic display
- Free contacts for compressor status and enabling

VERSION

- Low temperature liquid

- Well water application
- Tower water application

ACCESSORIES

- Rubber antivibration mounts (separately supplied accessories)
- Power factor correction capacitors
- Device for compressor gradual start-up
- Compressor overload circuit breakers
- Set point compensation with 0-10 V signal
- Set point compensation with 4-20 mA signal
- Set point compensation with outside temperature probe
- Set point compensation according to the outside enthalpy
- Electrical panel ventilation
- Microprocessor control unit (separately supplied accessories)
- MODBUS serial converter kit
- BACnet serial converter kit
- LonWorks serial converter kit
- Master-Slave function
- Pressure switch kit (separately supplied accessories)

TEST

All the units are factory-tested in specific steps before the shipping. After the approval, the humidity content, present in all circuits, is analyzed in order to ensure the respect of the limits set by the manufacturers of the different components.

GENERAL TECHNICAL SPECIFICATIONS

SIZE		2.220	2.230	2.240	2.260	2.280	2.300	2.320	2.340	2.360	2.440	2.480	2.540	2.600	
COOLING															
Cooling capacity	1	kW	633	677	730	782	829	901	976	1045	1108	1226	1391	1549	1711
Compressor power input	1	kW	112	120	129	138	147	160	173	183	194	215	243	271	299
Total power input	1	kW	113	121	130	139	148	161	174	184	195	216	244	272	300
EER	1		5,60	5,60	5,62	5,63	5,60	5,60	5,61	5,68	5,68	5,68	5,70	5,69	5,70
ESEER			6,61	6,66	6,63	6,69	6,67	6,66	6,62	6,64	6,65	6,64	6,67	6,61	6,67
COMPRESSOR															
Type of compressors	2		DSW	DSW	DSW	DSW	DSW	DSW	DSW	DSW	DSW	DSW	DSW	DSW	DSW
No. of Compressors		Nr	2	2	2	2	2	2	2	2	2	2	2	2	2
Nominal capacity (C1)		HP	110	110	120	120	140	140	160	160	180	220	240	270	300
Nominal capacity C2)		HP	110	120	120	140	140	160	160	180	180	220	240	270	300
Std Capacity control steps		Nr	STEPLESS	STEPLESS	STEPLESS	STEPLESS	STEPLESS	STEPLESS	STEPLESS	STEPLESS	STEPLESS	STEPLESS	STEPLESS	STEPLESS	STEPLESS
Oil charge (C1)		l	17	17	17	17	17	17	23	23	23	23	25	25	25
Oil charge (C2)		l	17	17	17	17	17	23	23	23	23	23	25	25	25
Refrigerant circuits		Nr	2	2	2	2	2	2	2	2	2	2	2	2	2
EVAPORATOR															
Type	3		S&T	S&T	S&T	S&T	S&T	S&T	S&T	S&T	S&T	S&T	S&T	S&T	S&T
Number		Nr	1	1	1	1	1	1	1	1	1	1	1	1	1
Water flow rate	1	l/s	30,2	32,3	34,9	37,4	39,6	43	46,6	49,9	52,9	58,6	66,5	74	81,7
Pressure drop	1	kPa	44,2	49,9	57,3	45,6	50,6	36,5	42,3	52,4	53,5	35,4	26,4	32	38,1
Water content		l	585	585	585	560	535	535	535	535	963	931	931	931	931
Water fittings	4		6"	6"	6"	8"	8"	8"	8"	10"	10"	10"	10"	10"	10"
CONDENSER															
Type	3		S&T	S&T	S&T	S&T	S&T	S&T	S&T	S&T	S&T	S&T	S&T	S&T	S&T
Number		l/s	35,6	38,1	41	43,9	46,6	50,7	54,9	58,7	62,2	68,8	78,1	87	96
Water flow rate	1	kPa	55	56	57	56	54	51	51	53	55	56	56	56	48
Pressure drop	1	l	154	173	192	194	196	214	232	242	252	284	320	350	412
Water content		Nr	2	2	2	2	2	2	2	2	2	2	2	2	2
Water fittings	4		5"	5"	5"	5"	5"	5"	5"	5"	5"	6"	6"	6"	6"
POWER SUPPLY															
Standard power supply		V	400/3/50	400/3/50	400/3/50	400/3/50	400/3/50	400/3/50	400/3/50	400/3/50	400/3/50	400/3/50	400/3/50	400/3/50	400/3/50
STANDARD UNIT WEIGHTS															
Shipping weight		kg	3660	3700	3725	4000	4050	4350	4690	5100	5100	5760	6230	6720	6910
Operating weight		kg	4400	4450	4500	4750	4800	5100	5450	6320	6360	7000	7480	8000	8250

(1) data referred to the following conditions :
 - internal exchanger water = 12/7°C
 - external exchanger water = 30/35°C
 (2) DSW = twin-screw compressor

(3) S&T = tube bundle
 (4) Fittings with flexible joint and solder pipe connection

ELECTRICAL DATA

SIZE		2.220	2.230	2.240	2.260	2.280	2.300	2.320	2.340	2.360	2.440	2.480	2.540	2.600	
F.L.A. - FULL LOAD CURRENT AT MAX ADMISSIBLE CONDITIONS															
F.L.A. - Total		A	292	301	311	336	360	389	417	439	462	503	598	663	729
F.L.I. FULL LOAD POWER INPUT AT MAX ADMISSIBLE CONDITION															
F.L.I. - Total		kW	168	180	192	205	218	238	258	273	287	314	360	401	442
M.I.C. MAXIMUM INRUSH CURRENT															
M.I.C. - Value		A	370	426	436	436	461	535	56	583	605	795	850	1035	1156

Voltage unbalance: max 2 %
 Power supply: 400/3/50 Hz +/-6%
 Electrical data refer to standard units; according to the installed accessories, the data can suffer light variations.

OPERATING LIMITS (COOLING)

SIZE		2.220	2.230	2.240	2.260	2.280	2.300	2.320	2.340	2.360	2.440	2.480	2.540	2.600
CONDENSER														
Max water inlet temperature	1	°C	40	40	40	40	40	40	40	40	40	40	40	40
Max water inlet temperature	2	°C	41	41	41	41	41	41	41	41	41	41	41	41
Max water inlet temperature	3	°C	52	52	52	52	52	52	52	52	52	52	52	52
Min. water outlet temperature		°C	24	24	24	24	24	24	24	24	24	24	24	24
EVAPORATOR														
Max water inlet temperature		°C	20	20	20	20	20	20	20	20	20	20	20	20
Min. water outlet temperature	4	°C	5	5	5	5	5	5	5	5	5	5	5	5
Min. water outlet temperature	5	°C	-8	-8	-8	-8	-8	-8	-8	-8	-8	-8	-8	-8

(1) unit at full load: internal exchanger water 12/7°C
 (2) unit at part load (automatic capacity control)
 (3) unit not operating

(4) Standard Version
 (5) Low temperature liquid version (Fluid with ethylene glycol of 40%)

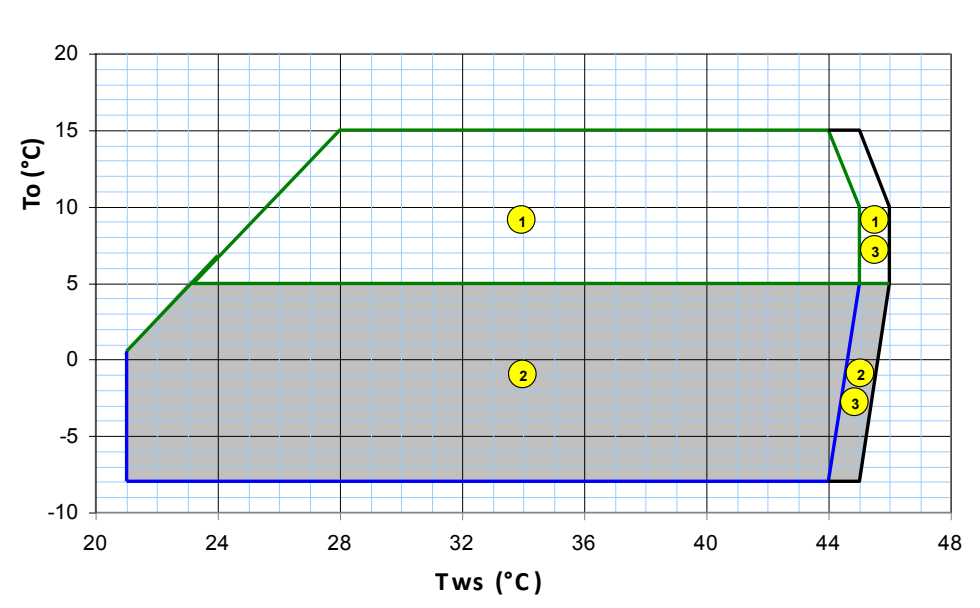

Data referred to a heat drop of 5°C
 To (°C) = outlet water temperature to the internal exchanger
 Tws (°C) = outlet water temperature to the external exchanger

- Standard unit: (not with 'Low temperature liquid' configuration)
- Low temperature liquid' unit (with ethylene glycol of 40%)
- Partial-load unit (automatic capacity control)

SOUND LEVEL

SIZE	Sound Power Level (dB)								Sound pressure level dB(A)	Sound power level dB(A)
	Octave band (Hz)									
	63	125	250	500	1000	2000	4000	8000		
2.220	92	83	89	95	96	86	78	72	80	98
2.230	93	84	89	96	97	87	78	73	80	99
2.240	74	60	85	100	98	83	62	44	82	101
2.260	84	64	86	96	100	86	63	45	82	101
2.280	89	66	97	99	100	85	60	41	83	102
2.300	87	79	96	98	100	85	68	49	83	102
2.320	84	83	94	97	101	86	71	52	83	89
2.340	82	81	96	98	100	86	70	52	82	101
2.360	79	79	98	99	99	87	70	53	82	101
2.440	83	82	94	97	100	85	71	52	82	102
2.480	83	82	94	97	100	85	71	51	82	101
2.540	83	82	94	97	100	85	71	52	82	102
2.600	94	82	87	103	97	94	84	75	83	102

The sound levels refer to the unit at full load, in the rated test conditions.
 The sound pressure level refers to a distance of 1m from the external surface of the units operating in an open field.
 Measures, according to ISO 3744 regulations, are carried out on a reflecting surface, with respect to the EUROVENT 8/1 certification.

Data referred to the following conditions:
 - internal exchanger water = 12/7°C
 - outdoor air temperature 35°C

ACOUSTIC CONFIGURATION: STANDARD (ST)



COOLING PERFORMANCES

SIZE	To (°C)	OUTLET WATER TEMPERATURE TO CONDENSER (°C)														
		30			32			35			40			45		
		kWf	kWe	kWt	kWf	kWe	kWt	kWf	kWe	kWt	kWf	kWe	kWt	kWf	kWe	kWt
2.220	5	610,7	97,0	707,7	601,9	103,1	705,0	588,0	112,6	700,6	563,0	129,8	692,8	535,7	148,4	684,1
	6	632,1	96,5	728,6	624,6	102,6	727,2	611,2	112,2	723,4	583,5	129,4	712,9	549,1	148,1	697,2
	7	653,9	95,9	749,8	646,6	102,1	748,7	633,3	111,8	745,1	604,4	129,0	733,4	567,2	147,7	714,9
	8	676,1	95,4	771,5	668,2	101,6	769,8	654,3	111,3	765,6	625,7	128,6	754,3	590,3	147,4	737,7
	9	698,8	94,8	793,6	689,2	101,0	790,2	674,2	110,8	785,0	647,3	128,2	775,5	618,2	147,0	765,2
	10	721,9	94,1	816,0	709,7	100,5	810,2	693,0	110,3	803,3	669,4	127,8	797,2	651,0	146,6	797,6
2.230	5	654,8	105,1	759,9	645,9	111,1	757,0	631,5	120,7	752,2	604,9	138,5	743,4	574,9	158,6	733,5
	6	677,8	104,9	782,7	668,7	110,9	779,6	654,0	120,5	774,5	626,9	138,3	765,2	596,4	158,3	754,7
	7	701,3	104,7	806,0	692,0	110,6	802,6	676,9	120,3	797,2	649,3	138,1	787,4	618,3	158,1	776,4
	8	725,2	104,4	829,6	715,6	110,4	826,0	700,3	120,0	820,3	672,1	137,8	809,9	640,6	157,9	798,5
	9	749,6	104,2	853,8	739,8	110,2	850,0	724,0	119,8	843,8	695,3	137,6	832,9	663,3	157,6	820,9
	10	774,4	104,0	878,4	764,3	109,9	874,2	748,2	119,6	867,8	718,9	137,4	856,3	686,4	157,4	843,8
2.240	5	705,2	113,2	818,4	696,1	119,1	815,2	681,1	128,8	809,9	652,6	147,3	799,9	619,7	168,7	788,4
	6	730,1	113,3	843,4	720,8	119,1	839,9	705,5	128,8	834,3	676,4	147,2	823,6	642,9	168,6	811,5
	7	755,5	113,4	868,9	745,9	119,2	865,1	730,2	128,8	859,0	700,5	147,1	847,6	666,5	168,5	835,0
	8	781,4	113,5	894,9	771,5	119,3	890,8	755,3	128,8	884,1	725,0	147,0	872,0	690,5	168,3	858,8
	9	807,7	113,7	921,4	797,5	119,3	916,8	780,9	128,8	909,7	750,0	147,0	897,0	714,9	168,2	883,1
	10	834,4	113,8	948,2	823,9	119,4	943,3	806,9	128,8	935,7	775,4	146,9	922,3	739,8	168,1	907,9
2.260	5	757,9	120,9	878,8	747,1	127,4	874,5	729,9	137,8	867,7	699,2	157,0	856,2	665,8	178,6	844,4
	6	785,0	121,1	906,1	773,7	127,5	901,2	756,0	137,8	893,8	724,5	156,9	881,4	690,5	178,5	869,0
	7	812,5	121,2	933,7	800,7	127,5	928,2	782,4	137,8	920,2	750,1	156,8	906,9	715,6	178,3	893,9
	8	840,4	121,4	961,8	828,2	127,6	955,8	809,3	137,8	947,1	776,2	156,7	932,9	741,1	178,1	919,2
	9	868,9	121,6	990,5	856,2	127,8	984,0	836,6	137,8	974,4	802,7	156,6	959,3	767,1	178,0	945,1
	10	897,8	121,8	1020	884,6	127,9	1013	864,3	137,9	1002	829,5	156,5	986,0	793,4	177,8	971,2
2.280	5	804,8	128,6	933,4	792,3	135,7	928,0	773,4	146,9	920,3	741,0	166,9	907,9	707,7	188,7	896,4
	6	833,6	128,8	962,4	820,6	135,8	956,4	800,9	146,8	947,7	767,6	166,7	934,3	733,7	188,4	922,1
	7	863,0	129,0	992,0	849,4	135,9	985,3	828,9	146,8	975,7	794,6	166,6	961,2	760,1	188,2	948,3
	8	892,9	129,2	1022	878,7	136,0	1015	857,4	146,9	1004	822,1	166,5	988,6	787,0	188,0	975,0
	9	923,3	129,4	1053	908,4	136,2	1045	886,3	146,9	1033	849,9	166,3	1016	814,3	187,8	1002
	10	954,3	129,7	1084	938,7	136,3	1075	915,6	146,9	1063	878,3	166,2	1045	842,1	187,6	1030
2.300	5	869,9	140,3	1010	858,1	147,8	1006	839,4	160,0	999,4	805,3	182,5	987,8	767,8	207,6	975,4
	6	901,3	140,3	1042	889,1	147,9	1037	869,7	160,0	1030	834,8	182,3	1017	796,5	207,4	1004
	7	933,5	140,4	1074	920,8	147,9	1069	900,8	160,0	1061	864,9	182,2	1047	825,8	207,2	1033
	8	966,3	140,5	1107	953,2	148,0	1101	932,5	159,9	1092	895,6	182,1	1078	855,8	207,1	1063
	9	999,9	140,7	1141	986,2	148,0	1134	964,9	160,0	1125	927,0	182,0	1109	886,4	206,9	1093
	10	1034	140,8	1175	1020	148,1	1168	998,0	160,0	1158	959,1	181,9	1141	917,6	206,7	1124
2.320	5	937,2	151,8	1089	926,3	159,9	1086	908,0	173,1	1081	872,6	198,0	1071	831,1	226,5	1058
	6	971,3	151,8	1123	960,1	159,9	1120	941,4	173,1	1115	905,2	197,9	1103	862,7	226,3	1089
	7	1006	151,8	1158	994,7	159,8	1155	975,6	173,0	1149	938,5	197,8	1136	895,0	226,2	1121
	8	1042	151,8	1194	1030	159,8	1190	1010	173,0	1183	972,5	197,8	1170	928,0	226,1	1154
	9	1078	151,8	1230	1066	159,8	1226	1046	173,0	1219	1007	197,7	1205	961,8	225,9	1188
	10	1116	151,8	1268	1103	159,9	1263	1083	173,0	1256	1043	197,6	1241	996,2	225,8	1222

To = Outlet water temperature to condenser (°C)
 kWf = Cooling capacity (kW)
 kWe = Compressor power input (kW)
 kWt = Provided heating capacity (kW)
 Performances in function of the inlet/outlet water temperature differential = 5°C

ACOUSTIC CONFIGURATION: STANDARD (ST)



COOLING PERFRMANCES

SIZE	To (°C)	OUTLET WATER TEMPERATURE TO CONDENSER (°C)														
		30			32			35			40			45		
		kWf	kWe	kWt	kWf	kWe	kWt	kWf	kWe	kWt	kWf	kWe	kWt	kWf	kWe	kWt
2.340	5	1014	161,2	1175	998,3	169,5	1168	973,7	183,3	1157	929,2	209,6	1139	880,3	240,3	1121
	6	1050	161,3	1211	1034	169,6	1204	1009	183,2	1192	964,0	209,5	1174	914,3	240,1	1154
	7	1086	161,4	1247	1071	169,6	1241	1045	183,2	1228	999,5	209,4	1209	949,2	239,9	1189
	8	1124	161,5	1286	1108	169,7	1278	1082	183,2	1265	1036	209,3	1245	985,0	239,8	1225
	9	1162	161,7	1324	1146	169,8	1316	1120	183,3	1303	1073	209,2	1282	1022	239,6	1262
	10	1201	161,9	1363	1184	169,9	1354	1158	183,3	1341	1111	209,2	1320	1059	239,4	1298
2.360	5	1079	170,8	1250	1060	179,3	1239	1029	193,6	1223	976,3	221,5	1198	920,7	254,5	1175
	6	1117	171,0	1288	1099	179,4	1278	1070	193,6	1264	1012	221,4	1233	945,3	254,3	1200
	7	1154	171,2	1325	1137	179,6	1317	1108	193,7	1302	1049	221,3	1270	978,4	254,0	1232
	8	1193	171,5	1365	1175	179,8	1355	1145	193,7	1339	1087	221,2	1308	1020	253,8	1274
	9	1231	171,8	1403	1211	179,9	1391	1180	193,8	1374	1126	221,1	1347	1070	253,6	1324
	10	1271	172,1	1443	1246	180,2	1426	1212	193,9	1406	1165	221,0	1386	1129	253,4	1382
2.440	5	1190	190,2	1380	1167	198,9	1366	1133	213,7	1347	1075	242,7	1318	1017	277,0	1294
	6	1236	191,0	1427	1215	199,6	1415	1180	214,1	1394	1115	242,7	1358	1041	276,8	1318
	7	1284	191,9	1476	1262	200,3	1462	1226	214,6	1441	1157	242,8	1400	1077	276,5	1354
	8	1333	192,9	1526	1308	201,1	1509	1269	215,2	1484	1199	243,0	1442	1122	276,3	1398
	9	1383	193,9	1577	1354	202,0	1556	1310	215,7	1526	1242	243,1	1485	1177	276,1	1453
	10	1434	195,1	1629	1398	202,9	1601	1350	216,4	1566	1286	243,3	1529	1243	275,9	1519
2.480	5	1357	213,9	1571	1331	224,9	1556	1291	242,8	1534	1223	276,6	1500	1154	315,4	1469
	6	1404	214,1	1618	1381	225,0	1606	1343	242,8	1586	1269	276,6	1546	1183	315,3	1498
	7	1451	214,3	1665	1429	225,2	1654	1391	242,9	1634	1316	276,6	1593	1224	315,2	1539
	8	1498	214,6	1713	1475	225,3	1700	1437	243,0	1680	1363	276,5	1640	1277	315,1	1592
	9	1546	214,8	1761	1520	225,5	1746	1480	243,1	1723	1412	276,5	1689	1342	315,0	1657
	10	1595	215,1	1810	1563	225,8	1789	1521	243,3	1764	1462	276,5	1739	1418	314,9	1733
2.540	5	1519	239,5	1759	1488	251,9	1740	1442	271,9	1714	1367	308,8	1676	1294	350,1	1644
	6	1572	239,8	1812	1542	252,1	1794	1496	272,0	1768	1418	308,7	1727	1340	349,9	1690
	7	1626	240,2	1866	1595	252,4	1847	1549	272,1	1821	1470	308,6	1779	1390	349,7	1740
	8	1681	240,6	1922	1649	252,7	1902	1602	272,2	1874	1524	308,5	1833	1444	349,6	1794
	9	1736	241,1	1977	1704	253,0	1957	1655	272,4	1927	1578	308,5	1887	1503	349,4	1852
	10	1793	241,6	2035	1758	253,4	2011	1708	272,6	1981	1633	308,4	1941	1567	349,2	1916
2.600	5	1669	264,6	1934	1636	277,5	1914	1586	298,7	1885	1502	339,5	1842	1416	387,1	1803
	6	1730	265,3	1995	1699	277,9	1977	1650	298,9	1949	1557	339,4	1896	1453	386,8	1840
	7	1792	266,0	2058	1761	278,5	2040	1711	299,2	2010	1614	339,3	1953	1503	386,5	1890
	8	1855	266,8	2122	1822	279,0	2101	1769	299,5	2069	1672	339,3	2011	1566	386,2	1952
	9	1919	267,7	2187	1881	279,7	2161	1824	299,8	2124	1731	339,2	2070	1643	385,9	2029
	10	1985	268,7	2254	1938	280,4	2218	1875	300,2	2175	1792	339,1	2131	1734	385,6	2120

To = Outlet water temperature to condenser (°C)
 kWf = Cooling capacity (kW)
 kWe = Compressor power input (kW)
 kWt = Provided heating capacity (kW)
 Performances in function of the inlet/outlet water temperature differential = 5°C

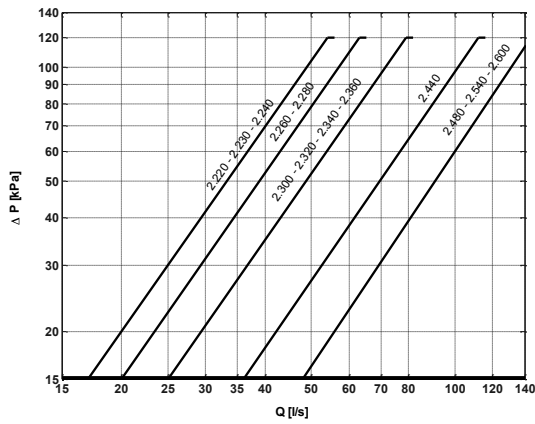
ACOUSTIC CONFIGURATION: STANDARD (ST)
INTERNAL EXCHANGER PRESSURE DROPS (EVAPORATOR)

THE AIR SIDE PRESSURE DROPS ARE RELATIVE TO THE MEDIUM WATER TEMPERATURE OF 7°C

Q = WATER FLOW-RATE [l/s]
DP = PRESSURE DROP [kPa]

THE WATER FLOW RATE CAN BE CALCULATED WITH THE FOLLOWING FORMULA:

$$Q \text{ [l/s]} = \text{kWf} / (4,186 \times \text{DT})$$

kWf = COOLING CAPACITY [kW]
DT = TEMPERATURE DIFFERENCE BETWEEN WATER INLET / OUTLET

		2.220	2.230	2.240	2.260	2.280	2.300	2.320	2.340	2.360	2.440	2.480	2.540	2.600
Qmin	[l/s]	16,8	16,8	16,8	20,0	20,0	24,6	24,6	24,7	24,6	31,4	41,9	41,9	41,9
Qmax	[l/s]	54,4	54,4	54,4	63,3	63,3	79,2	79,2	79,4	79,2	100	133	133	133

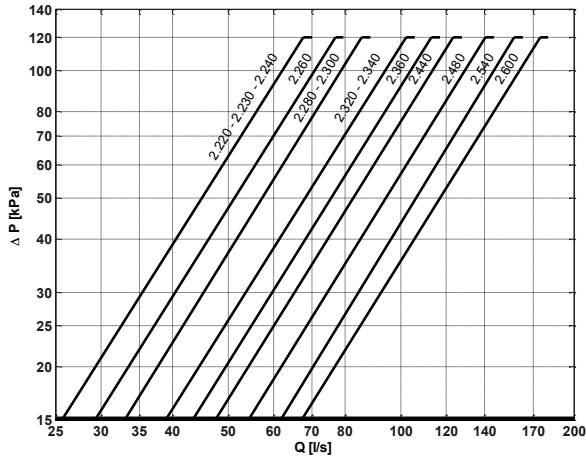
EXTERNAL EXCHANGER PRESSURE DROPS (CONDENSER)- WELL WATER APPLICATION

		2.220	2.230	2.240	2.260	2.280	2.300	2.320	2.340	2.360	2.440	2.480	2.540	2.600
Qmin	[l/s]	25	25,7	27,3	29,3	33	34,3	36,9	38,9	43,4	47,5	54,2	61,7	67,2
Qmax	[l/s]	65,1	67,5	71,9	76,8	85,5	89	95,9	102	113	123	140	157	175

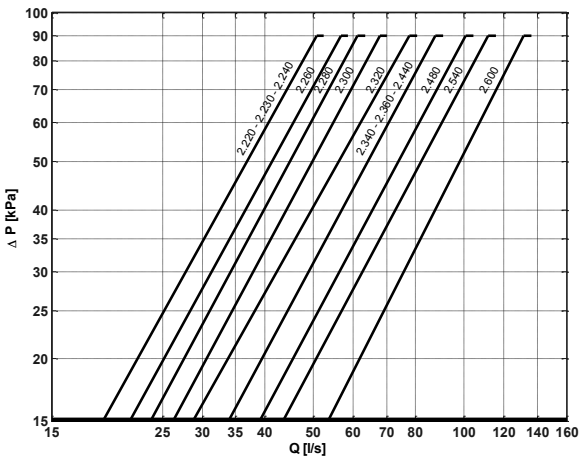
EXTERNAL EXCHANGER PRESSURE DROPS (CONDENSER) - TOWER WATER APPLICATION

		2.220	2.230	2.240	2.260	2.280	2.300	2.320	2.340	2.360	2.440	2.480	2.540	2.600
Qmin	[l/s]	17,7	18,6	19,4	21,5	23,8	26,2	28,8	30,2	31,5	33,9	39,1	43,4	53,5
Qmax	[l/s]	46,1	49,2	52,2	56,7	61,3	67,8	74,5	77,8	81,1	87,7	101	112	131

CORRECTION FACTOR FOR ANTIFREEZE SOLUTIONS

INTERNAL EXCHANGER (EVAPORATOR)

% ethylene glycol by weight		5%	10%	15%	20%	25%	30%	35%	40%
Freezing temperature	°C	-2,0	-3,9	-6,5	-8,9	-11,8	-15,6	-19,0	-23,4
Safety temperature	°C	3,0	1,0	-1,0	-4,0	-6,0	-10,0	-14,0	-19,0
Cooling Capacity Factor	Nr	0,995	0,990	0,985	0,981	0,977	0,974	0,971	0,968
Compressor input Factor	Nr	0,997	0,993	0,990	0,988	0,986	0,984	0,982	0,981
Internal exchanger Glycol solution flow Factor	Nr	1,003	1,010	1,020	1,033	1,050	1,072	1,095	1,124
Pressure drop Factor	Nr	1,029	1,060	1,090	1,118	1,149	1,182	1,211	1,243

The correction factors shown refer to water and glycol ethylene mixtures used to prevent the formation of frost on the exchangers in the water circuit during the inactivity in winter.

EXTERNAL EXCHANGER (CONDENSER)

% ethylene glycol by weight		5%	10%	15%	20%	25%	30%	35%	40%
Freezing temperature	°C	-2,0	-3,9	-6,5	-8,9	-11,8	-15,6	-19,0	-23,4
Safety temperature	¹ °C	-0,3	-0,6	-0,9	-1,3	1,8	-2,2	-2,7	-3,3
Cooling Capacity Factor	Nr	1,00	0,99	0,99	0,98	0,97	0,97	0,96	0,95
Compressor input Factor	Nr	1,01	1,01	1,02	1,02	1,03	1,04	1,05	1,06
Internal exchanger Glycol solution flow Factor	Nr	1,01	1,02	1,04	1,05	1,07	1,09	1,11	1,13
Pressure drop Factor	Nr	1,02	1,05	1,08	1,12	1,16	1,21	1,26	1,32

The correction factors shown refer to water and glycol ethylene mixtures used to prevent the formation of frost on the exchangers in the water circuit during the inactivity in winter.

(1) REDUCTION OF THE MAX. INLET WATER TEMPERATURE TO THE EXTERNAL EXCHANGER

FOULING CORRECTION FACTORS

m ² °C/W	INTERNAL EXCHANGER		EXTERNAL EXCHANGER	
	F1	FK1	F2	FK2
0.44 x 10 ⁽⁻⁴⁾	1,00	1,00	1,00	1,00
0.88 x 10 ⁽⁻⁴⁾	0,97	0,99	0,97	1,08
1.76 x 10 ⁽⁻⁴⁾	0,94	0,98	0,92	1,05

F1 = Cooling capacity correction factor
 FK1 = Compressor power input correction factor
 F2 = Cooling capacity correction factor
 FK2 = Compressors input power correction factor

EXCHANGER OPERATING LIMITS

	INTERNAL EXCHANGER		INTERNAL EXCHANGER	
	DPr		DPw	DPr
	kPa		kPa	kPa
CLIVET (C)	2450 (1600)	2450 (1600)	1050	3000
PED (CE)	2450 (1600)	2450 (1600)	1050	3000

DPr = Maximum operating pressure on cooling side
 DPw = Maximum operating pressure on water side

OVERLOAD AND CONTROL DEVICE CALIBRATION

		OPEN	CLOSED	VALUE
High safety pressure switch	kPa	1250	950	-
Low safety pressure switch	kPa	70,0	170	-
Antifreeze protection	°C	3,0	5,5	-
High pressure safety valve	kPa	-	-	2000
Low pressure safety valve	kPa	-	-	1650
Max no. of compressor starts per hour	Nr	-	-	6
High compressor discharge temperature safety thermostat	°C	-	-	120

VERSIONS

B - LOW WATER TEMPERATURE

Version also known as "Brine". It enables a non-freezable solution to be cooled (for instance, water and ethylene glycol in appropriate quantities) up to a temperature of between +4°C and -8°C.

It includes:

- Appropriate exchangers, complete with thick insulation of the closed-cell type;
- Electronic expansion valve, functional calibrations and safety devices suitable to the particular use.

-  In the selection phase, it is necessary to indicate the type of required function, which the unit will be optimised on:
- Unit with single working set-point (only at low temperature)
 - Unit with double working set-point.

-  The unit in this configuration has a different operating range, indicated in the previous pages.

-  When operating at low temperature, some steps of part loading may not be available.
For more information contact the sales network Clivet.

P - WELL WATER APPLICATION

Version optimised for the operating with source at reduced temperature and water flow-rate. Suitable for applications which use sheet, well, river and lake water sources for cooling (checking any requirements for water treatment is entrusted to the Client). The condenser is sized for the operating with a nominal thermal gradient of 15°C between the supply water inlet and outlet.

T - TOWER WATER APPLICATION

Version optimised for the operating with sources at higher temperature and water flow-rate. Suitable for applications which use evaporating tower water or dry cooler sources for cooling (checking any requirements for water treatment is entrusted to the Client). The condenser is sized for the operating with a nominal thermal gradient of 5°C between the supply water inlet and outlet.

ACCESSORIES

AMRX - RUBBER ANTIVIBRATION MOUNTS

The rubber anti-vibration devices are fastened in housings on the longitudinal members. They reduce the vibrations caused by the unit, reducing the noises transmitted by the support structures.

Elastic bodies are able to dampen axial and tangential stresses and to maintain the physical and mechanical properties almost constant over time thanks to high strength materials of which they are made. As an alternative to the anti-vibration rubber can be adopted some neoprene rubber bands placed under the longitudinal member (not supplied by Clivet).

 Accessory separately supplied



PFCP - POWER FACTOR CORRECTION CAPACITORS

The component is necessary to lower the phase difference between current and voltage in the unit electromagnetic components, such as asynchronous motors. Correcting the power factor it is possible to reduce the current intensity reducing a part of the capacity from the mains (reactive capacity). This often leads to an economic benefit which the energy provider grants to the final user. The component makes it possible to bring the cosφ power factor to values which on average are greater than 0.9.

The device is installed and wired built-in.



SFSTR2 - DEVICE FOR COMPRESSOR GRADUAL START-UP

Option also known as 'Soft starter'. Automatic electronic device for the compressor gradual start-up .

The device is installed and wired built-in.

CBS - COMPRESSOR OVERLOAD CIRCUIT BREAKERS

The overload circuit breakers are used instead of the fuses for protection against short-circuits and overloads. If they are activated they do not need to be replaced, unlike the fuses.



The device is installed and wired built-in.

SPC4 - SPC4 - SET POINT COMPENSATION WITH 0-10 V SIGNAL

The device allows the variation of the set-point pre-set by an external 0÷10 V signal.

- It allows:
- the consumption reduction in the conditioning applications;
 - the adaptation to the making in the process applications.

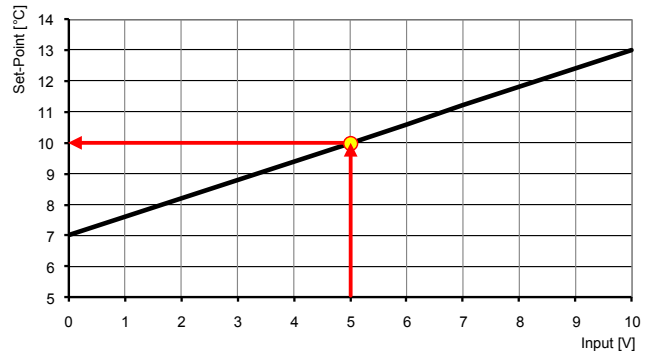

The device is installed and wired built-in.

SPC1 - SET POINT COMPENSATION WITH 4-20 mA

The device allows the variation of the set-point PRE-SET by an external 4÷20 mA signal.

- It allows:
- the consumption reduction in the conditioning applications;
 - the adaptation to the making in the process applications.



The device is installed and wired built-in.

SPC2 - SET POINT COMPENSATION WITH OUTSIDE TEMPERATURE PROBE

The device allows the automatic adjustment of the set-point pre-set according to the outside air temperature.

It provides the liquid *sliding* temperature, that is variable depending on the external conditions, for the benefit of the energy saving of the system.

- ⚠ The SPC2 option is supplied with the outdoor air temperature sensor kit (cable max. length 20 m and the outdoor installation are provided by customer).

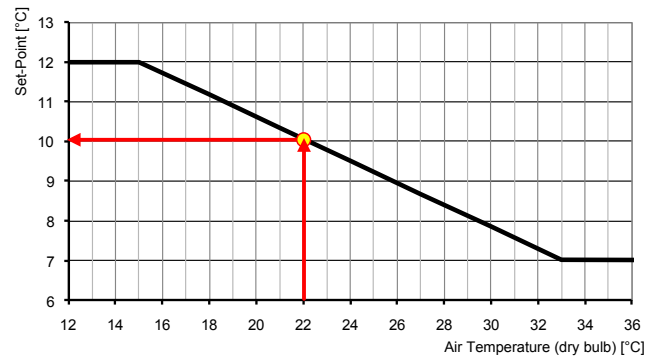

SPC3 - SET POINT COMPENSATION ACCORDING TO THE OUTSIDE ENTHALPY

The device allows the automatic adjustment of the unit set-point according to the outside enthalpy.

It provides the liquid *sliding* temperature, that is variable depending on the external conditions, for the benefit of the energy saving of the system.

- ⚠ The SCP3 option is supplied complete with the outdoor air enthalpy sensor kit (cable max. length 20 m and the outdoor installation are provided by customer).

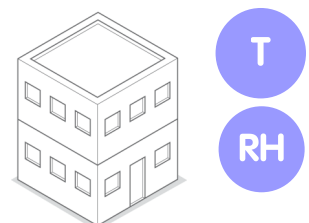



FANQE – ELECTRICAL PANEL VENTILATION

This option is necessary for very hot climates, where the outside temperature can be between +40°C and +49°C. It is made up of a forced ventilation system, activated by a thermostat, which provides for the maintenance of the correct operating temperature of the components inside the electrical panel. The option includes a thermostat which activates the forced ventilation when necessary.



The device is installed and wired built-in.

-  This accessory is always operating even when the unit is switched off as long as the power supply is maintained and the unit is not isolated.
-  In order to guarantee that the correct unit operating, the temperature inside the unit must not exceed 50°C. Therefore, during storage or when the unit is already installed but not powered, it is necessary to avoid exceeding the above-indicated temperature. When the unit has been installed, the protections and safety devices are active only with the power supply switched on and the unit not isolated.

RCMRX - REMOTE MICROPROCESSOR CONTROL UNIT

Option to control all unit functions from remote. It can be easily wall mounted, it is equal to the user interface on the unit. The device has a simple interface with icon and button menu.

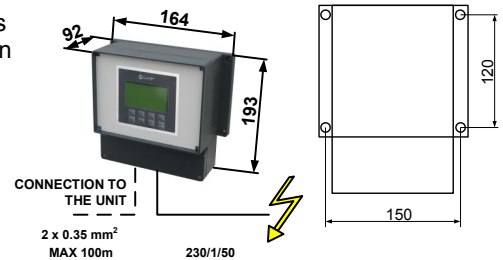

 Accessory separately supplied

-  The device must be installed on a wall using appropriate screw anchors, electrically powered and connected to the unit (installation and wiring provided by the customer)

CMSC9 - MODBUS SERIAL CONVERTER KIT

It allows the serial connection to supervision systems, using ModBus as the communication protocol. It allows the access to the complete list of operating variables, controls and alarms. By this accessory, each unit can communicate with the main supervision systems.



The device is installed and wired built-in.

CMSC8 - BACNET SERIAL CONVERTER KIT

It allows the serial connection to supervision systems, using BACnet as the communication protocol. It allows the access to the complete list of operating variables, controls and alarms. With this accessory, each unit can communicate with the main systems of supervision.



The device is installed and wired built-in.



-  The configuration and the management of the BACnet network are provided by the Customer

CMSC10 - LonWorks SERIAL CONVERTER KIT

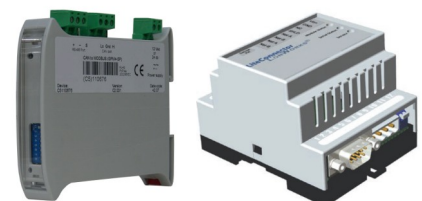
It allows the serial connection to supervision systems, using LonWorks as the communication protocol. It allows the access to a list of operating variables, controls and alarms compliant with the Echelon® standard.



The device is installed and wired built-in.

-  The configuration and the management of the LonWorks network are provided by the Customer.
-  The LonWorks technology uses LonTalk® protocol for the communication between network nodes. Contact your service provider for more information.

MSL - MASTER - SLAVE

The device allows the automatic management of a group of units which operate on the same hydraulic circuit, through the creation of a local communication network.

Among the enabled functions: optimised activation of the group compressors, rotation depending on the minimum wear criteria, management of the unit in stand-by mode.

The units can have different sizes. Each unit must be equipped with a Master-Slave device. The control of the group is entrusted to the unit identified as Master.

The local network can be extended up to 6 units.



The device is installed and wired built-in.



The unit with this device can be equipped simultaneously also with the RCMRX option and one of these options: CMSC8 / CMSC9 / CMSC10.

PVSX - PRESSURE SWITCH VALVE KIT

The pressure switch valves control the water flow-rate to the external exchangers according to the refrigerant condensing temperature. They allow the extension of the unit operating range and the reduction of the water consumption. The option includes a valve for each exchanger external side (condenser).



Accessory separately supplied



The option must be installed on the outlet liquid duct, source side, outside the unit (installed by the Customer).

OPTION COMPATIBILITY - WDH-HE SERIES

REF.	DESCRIPTION	2.220	2.230	2.240	2.260	2.280	2.300	2.320	2.340	2.360	2.440	2.480	2.540	2.600
CONFIGURATIONS AND MAIN OPTIONS														
B	Low temperature liquid	o	o	o	o	o	o	o	o	o	o	o	o	o
P	Well water application	o	o	o	o	o	o	o	o	o	o	o	o	o
T	Tower water application	o	o	o	o	o	o	o	o	o	o	o	o	o
B + P	Low temperature liquid + Well water application	o	o	o	o	o	o	o	o	o	o	o	o	o
B + T	Low temperature liquid + Tower water application	o	o	o	o	o	o	o	o	o	o	o	o	o
P + T	Well water application + Tower water application	x	x	x	x	x	x	x	x	x	x	x	x	x
P + PVSX	Well water application + Pressure switch valve kit	o	o	o	o	o	o	o	o	o	o	o	o	o
T + PVSX	Tower water application + Pressure switch valve kit	x	x	x	x	x	x	x	x	x	x	x	x	x
SFSTR2 + CBS	Device for compressor gradual start-up + overload circuit breakers	x	x	x	x	x	x	x	x	x	x	x	x	x
SFSTR2 + PFCP	Device for compressor gradual start-up + Power factor correction capacitors	o	o	o	o	o	o	o	o	o	o	o	o	o

DIMENSIONAL DRAWING

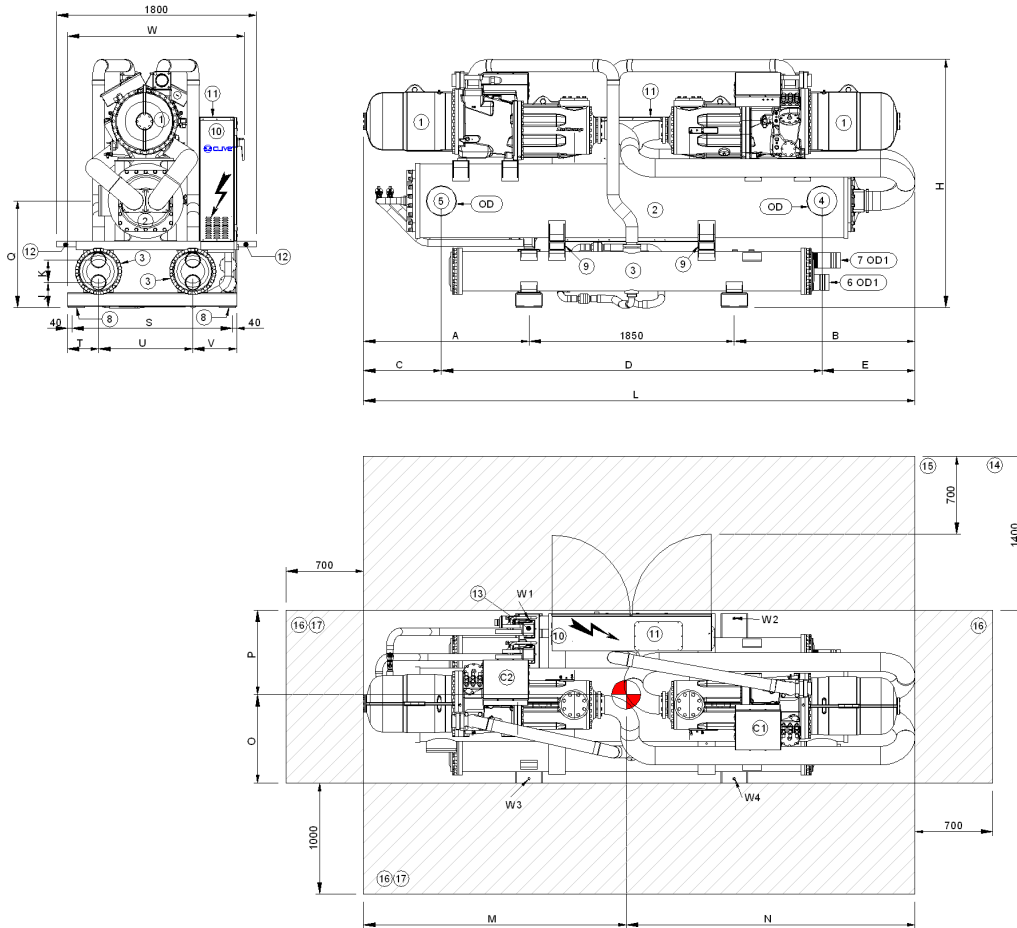

- (1) COMPRESSOR
- (2) INTERNAL EXCHANGER (EVAPORATOR)
- (3) EXTERNAL EXCHANGER (CONDENSER)
- (4) INTERNAL EXCHANGER WATER INLET
- (5) INTERNAL EXCHANGER WATER OUTLET
- (4-5) FITTINGS WITH FLEXIBLE JOINT AND SOLDER PIPE CONNECTION
- (6) EXTERNAL EXCHANGER WATER INLET
- (7) EXTERNAL EXCHANGER WATER OUTLET
- (6-7) FITTINGS WITH FLEXIBLE JOINT AND SOLDER PIPE CONNECTION
- (8) HOLES TO HANG UNIT
- (9) LIFTING HOLES
- (10) ELECTRICAL PANEL
- (11) POWER INPUT
- (12) LIFTING DUCT
- (13) MINIMUM DIMENSION ON THE ELECTRICAL SWITCHBOARD SIDE.
- (14) MINIMUM DIMENSION FOR A SAFE PASSAGE WHEN THE DOOR OF THE ELECTRICAL SWITCHBOARD IS OPEN.
- (15) MINIMUM DIMENSION FOR A SAFE PASSAGE.
- (16) MINIMUM DIMENSION FOR MAINTENANCE.

SIZE	STANDARD													
		2.220	2.230	2.240	2.260	2.280	2.300	2.320	2.340	2.360	2.440	2.480	2.540	2.600
Length (L)	mm	4900	4900	4900	4900	4900	4900	4900	4900	4900	4900	4970	4970	4970
Depth (W)	mm	1460	1460	1460	1520	1520	1520	1520	1620	1620	1620	1620	1620	1620
Height (H)	mm	2000	2000	2000	2090	2090	2090	2090	2240	2240	2370	2410	2410	2410
A	mm	1340	1340	1340	1421	1421	1421	1421	1421	1421	1421	1491	1491	1491
B	mm	1710	1710	1710	1629	1629	1629	1629	1629	1629	1629	1629	1629	1629
C	mm	491	491	491	530	530	530	530	630	630	630	700	700	700
D	mm	3562	3562	3562	3510	3510	3510	3510	3430	3430	3430	3430	3430	3430
E	mm	847	847	847	860	860	860	860	840	840	840	840	840	840
J	mm	228	228	228	228	228	228	228	228	228	228	228	228	228
K	mm	200	200	200	200	200	200	200	200	200	200	200	200	200
M	mm	2288	2288	2288	2326	2326	2287	2339	2471	2471	2479	2495	2495	2495
N	mm	2612	2612	2612	2574	2574	2613	2561	2429	2429	2421	2475	2475	2475
O	mm	646	646	646	617	817	779	814	472	472	953	750	750	750
P	mm	679	679	679	708	708	746	711	1053	1053	622	825	825	825
Q	mm	850	850	850	888	888	888	888	963	963	1116	1116	1116	1116
S	mm	1300	1300	1300	1360	1360	1360	1360	1445	1445	1445	1445	1445	1445
T	mm	335	335	335	335	335	335	335	280	280	280	280	280	280
U	mm	650	650	650	700	700	700	700	850	850	850	850	850	850
V	mm	395	395	395	405	405	405	405	395	395	395	395	395	395
OD	mm	168,3	168,3	168,3	219	219	219	219	273	273	273	273	273	273
OD1	mm	139,7	139,7	139,7	139,7	139,7	139,7	139,7	139,7	139,7	168	168	168	168
W1	kg	1092	1105	1117	1179	1344	1415	1500	833	838	1865	1655	1771	1826
W2	kg	1148	1161	1174	1129	1288	1245	1477	1094	1100	2491	1965	2101	2167
W3	kg	1053	1065	1077	1247	1107	1298	1246	1900	1912	1132	1765	1888	1947
W4	kg	1107	1119	1132	1194	1061	1142	1227	2493	2509	1512	2095	2240	2310
Operating weight	kg	4400	4450	4500	4750	4800	5100	5450	6320	6360	7000	7480	8000	8250
Shipping weight	kg	3660	3700	3725	4000	4050	4350	4690	5100	5100	5760	6230	6720	6910

The presence of optional components may imply a substantial variation of the weights shown in the table.

**CLIVET SPA**

Via Camp Lonc 25, Z.I. Villapaiera - 32032 Feltre (BL) - Italy
Tel. + 39 0439 3131 - Fax + 39 0439 313300 - info@clivet.it

CLIVET UK LTD

4 Kingdom Close, Segensworth East - Fareham, Hampshire - PO15 5TJ - United Kingdom
Tel. + 44 (0) 1489 572238 - Fax + 44 (0) 1489 573033 - info@clivet-uk.co.uk

CLIVET SAS

ZAC des Godets 1, Impasse de la Noisette, Hall A6 - 91370 Verrières le Buisson - France
Tel. + 33 (0)1 69202575 - Fax + 33 (0)1 69206076 - info.fr@clivet.com

CLIVET ESPAÑA S.A.

Parque Empresarial Villapark, Avda. Quitapesares 50 - 28670, Villaviciosa de Odón, Madrid - España
Tel. + 34 91 6658280 - Fax + 34 91 6657806 - info@clivet.es

CLIVET GmbH

Hummelsbütteler Steindamm 84, 22851 Norderstedt - Germany
Tel. + 49 (0) 40 32 59 57-0 - Fax + 49 (0) 40 32 59 57-194 - info.de@clivet.com

CLIVET NEDERLAND B.V.

Siliciumweg 20a, 3812 SX Amersfoort - Netherlands
Tel. + 31 (0) 33 7503420 - Fax + 31 (0) 33 7503424 - info@clivet.nl

CLIVET RUSSIA

Elektrozavodskaya st. 24, office 509 - 107023, Moscow, Russia
Tel. + 74956462009 - Fax + 74956462009 - info.ru@clivet.com

CLIVET MIDEAST FZC

Rep Office: PO Box 28178 - Suite 24, Al Abbas Building 1-B - Khalid Bin Waleed Street - Bur Dubai - Dubai, UAE
Tel. + 97 14 3518501 - Fax + 97 14 3518502 - info@clivetme.com

CLIVET TF AIR SYSTEMS (P)LTD.

Plot No.222-224 and 229-232 - Kiadb Indl Area III PHSE MALUR - 563103 KOLAR DIST - Malur - India
Tel. + 91 8151232683/5 - Fax + 91 8151232684 - info@clivettfa.com

The data contained in this bulletin is not binding and may be changed by the manufacturer without prior notice.
All reproduction, even partial, is prohibited. © Copyright - CLIVET S.p.A. - Feltre (BL) - Italy

www.clivet.com