



WSH-EE 17-121

WATER COOLED WATER CHILLER FOR INDOOR INSTALLATION



- ✓Versatile for every application:
 - terminal units and radiant panels
 - for system with water to waste application or geothermal system
- ✓Reduced energy consumption
- ✓Water group supplied as standard

WSH-EE 17 - 121 (R-410A)

Size	Cooling [kW]	Heating [kW]
17	5,95	7,00
21	6,42	7,63
31	7,90	9,28
41	10,5	12,0
51	13,4	15,6
61	16,7	19,1
71	20,2	23,4
81	22,1	25,1
91	25,8	29,5
101	30,5	34,3
121	35,0	39,3



The ELFOENERGY series chillers represent an important stage in the development of this type of unit. They feature the most up-to-date advances in technology, standing out for:

EFFICIENCY

thanks to its special construction, the ELFOENERGY ensures high energy efficiency, in particular during operation at partial loads;

SELF-ADAPTING

the evolved electronics implemented adapt the operating parameters of the chiller to the load conditions of the system it is installed in, optimising consumption, efficiency and the working life of the components;

EASE OF INSTALLATION

each unit is supplied as standard with a complete hydronic assembly and is completely tested in the factory; installation is consequently quick and easy.

Clivet is participating in the EUROVENT Certification Programme "Liquid Chilling Packages". Products are listed in the EUROVENT Directory of Certified Products and in the site www.eurovent-certification.com. Eurovent Chillers Certification Programme covers air cooled packaged chillers up to 600 kW and water cooled packaged chillers up to 1500 kW.



CERTIFIED QUALITY SYSTEM UNI EN ISO 9001:2000

OPERATION VERSATILITY

The WSH/N-EE units have been studied to be used in the different existent system types without compromising the energy efficiency or operating level.

UTILITY SIDE

Thanks to its special construction characteristics, the units can be used in traditional systems with terminal units, or in systems with radiant panels for heating and cooling, producing water directly at the temperature required for this particular kind of system. The units are equipped with a hydronic kit on the user side (standard). The units can also be used to heat household water. The unit in this case is set up with special components to carry out this function. If there is the requirement to heat household water, the electronic control will or will not give priority to this requirement based on the initial setting and automatically setting the temperature of the water to be produced.

SOURCE SIDE

The WSHN-EE units (heat pump), WSH-EE (only cool) and WSHH-EE (only heating) are studied for the energy exploitation in the ground and in the water. These units are studied to be used with closed circuits through horizontal or vertical probes, that contain water with antifreeze solution or with open circuits with water to waste (well, etc.). The units can be supplied with hydronic kit source side (optional).

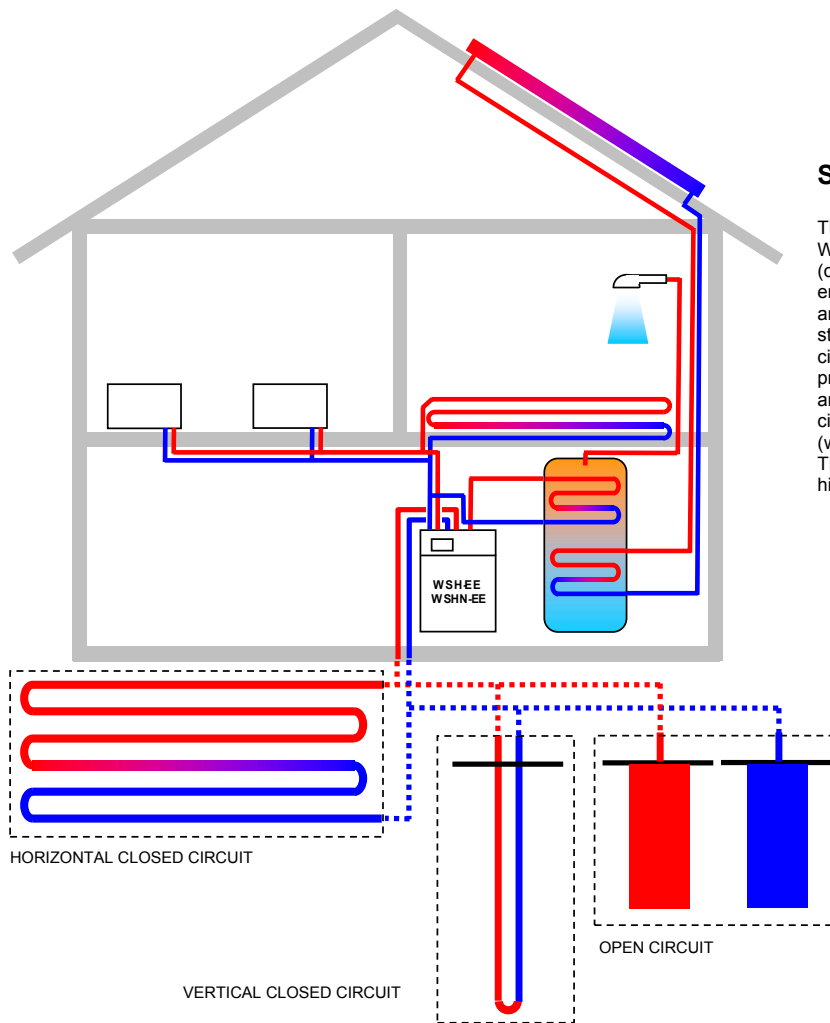

HIGH EFFICIENCY FOR MAX ENERGY SAVING AND MINIMUM ENVIRONMENTAL IMPACT

ENERGY EFFICIENCY					
Source side system	Use side system	Operation	Source side inlet temperature	Utility side temperature in outlet	COP in heating / EER in cooling (average of all sizes 17-121)
Geothermal probe (closed circuit)	Fan coil / radiators	Heating	0°C	50°C	2,61
	Radiant panels		0°C	35°C	4,03
Ground water (open circuit)	Fan coil / radiators		10°C	50°C	3,45
	Radiant panels		10°C	35°C	5,18
Geothermal probe or Ground water	Fan-Coil	Cooling	30°C (*)	7°C	5,12
	Radiant panels		30°C (*)	18°C	6,51

(*) TEMPERATURE WATER OUTLET TO THE EXCHANGER SOURCE SIDE

BT06G008GB-02

Complete unit and advanced control allow the system simplification and reduced dimensions.



HYDRONIC GROUP

The series WSH/N-EE has in the standard supply the hydronic group utility side. The variable flow-rate circulator assures the best operation of the unit even under the most critical conditions for the system, and enables to control the summer/winter operation change in reduced times. The units can also be required with hydronic group source side (optional).



MODULATING VALVE

The units can extend their field of operation by modulating the source side water flow rate based on the temperature through a modulating valve (optional) managed by the electronic control. This solution makes it possible to simplify the system rather than using the traditional pressure switch valve and the motorized bypass valve.

SLIDING TEMPERATURE

The smart electronics designed to optimize the compressor switching on/off cycles dramatically reduces both the operating transients, the time spent for each compressor switching-on to get the highest yield, and the harmful and expensive pickup currents. The adjustment based on this concept of SLIDING TEMPERATURES steadily searches for the best balance between power to be supplied and energy spent to produce it. In this way the accumulation is no longer needed, with obvious advantages as for electric consumption, space recovery and removal of heat dispersions.



SYSTEM HEART ELECTRONIC CONTROL

ELFOENERGY electronic control allows the several element management of the system:
control of possible integrative elements (electric heaters, boilers, etc..)
hot sanitary water production control
mixed system control (fan coil/radiators and radiant panels)



**WATER FILTERS
FITTED AS STANDARD**

Water filters source and utility side supplied as standard complete the accessories and components ELFOENERGY is standard equipped with.

LOW NOISE IS A DUTY

Noise is one of the most critical factors of this unit type. The use of special constructional solutions and the use of special materials for the acoustic insulation allowed the sound level reduction.



STANDARD-SUPPLIED USER KEYPAD

ELFOENERGY is supplied complete with remote user keypad, for the best control on the room comfort.

Electric - refrigerating - water alarm signals

Check comfort-economic-test control

SUMMER-WINTER-OFF signals

SUMMER-WINTER-OFF control



BT06G008GB-02

STANDARD UNIT SPECIFICATIONS

COMPRESSOR

Hermetic orbiting scroll compressor complete with motor over-temperature and over-current devices and protection against excessive gas discharge temperature. Fitted on rubber antivibration mounts and complete with oil charge

STRUCTURE

The base is assembled with a hot-galvanized steel frame (Z 200 g/m²). The internal structure is a frame made from «ALUZINK» metal plate. The alloy coating the Aluzink ensures excellent corrosion strength, thanks to the galvanic protection typical of the combination of aluminium and zinc.

PANELLING

The casing is made of prepainted steel sheet panels, completely lined with thermo-acoustic insulation with a class 1 fire resistance. The side panels are easily removable for total accessibility to the inside of the unit.

INTERNAL EXCHANGER

Direct expansion heat exchanger, braze-welded AISI 316 stainless steel plates with large exchange surface and complete with external heat and anti-condensate insulation.

EXTERNAL EXCHANGER

Direct expansion heat exchanger, braze-welded AISI 316 stainless steel plates with large exchange surface and complete with external heat and anti-condensate insulation.

REFRIGERANT CIRCUIT

The circuit is complete with:

- filter dryer
- thermostatic expansion valves with equalizer
- high pressure switch
- low pressure switch
- pressure probes

ELECTRICAL PANEL

The Power Section includes:

- auxiliary circuit fuse
- compressor control contactor
- Pump control source side
- compressor overload cutout switch

The control section includes:

- compressor overload protection and timer

- relay for remote cumulative fault signal
- terminals for double set point
- terminals of relè connection, for integrative elements' control
- Electronic for Elfo Control system (optional)

REMOTE KEYPAD FOR USER

removable control keypad, including:

- ON/OFF and alarm reset buttons
- heating and cooling operating mode buttons
- SLEEP button for optimised night-time operation
- signal led electric circuit alarm
- signal led refrigerant circuit alarm
- hydraulic circuit alarm signal led

HYDRAULIC CIRCUIT

UTILITY SIDE

- group of manual water charge with gauge
- variable flow-rate circulator
- diaphragm expansion vessel
- water side safety valve
- drain valve
- Flow Switch (size 61-71-81-91-101-121)
- differential pressure switch, water side (size 17-21-25-31-41-51)
- Steel mesh filter on source side
- Steel mesh filter on utility side

ACCESSOIRES SEPARATELY PROVIDED:

- IVMS - two way modulating motorised valve
- IWV - ON/OFF two ways motorized interception valve
- PM - phase monitor
- CMMB - serial communication module to supervisor (MODBUS)
- SCP3 - set point compensation according to the outside enthalpy
- SPC - set point compensation with outside temperature probe
- PBLC1 - Service keypad (cable from 1,5 metres)
- KDT3V - Double temperature control kit, set point compensation with 4-20mA, 3 ways valve.
- AMR - rubber antivibration mounts

CONFIGURATION CODE

Necessary configuration string for supplying the unit with the indicated elements.

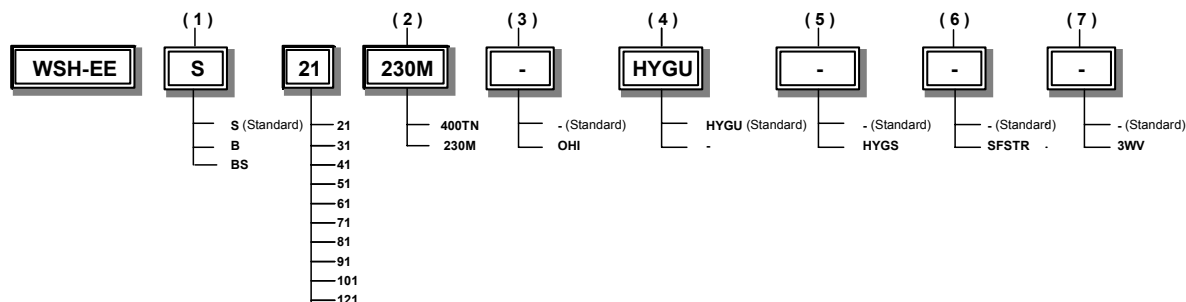

(1) VERSION

Standard Version(S)

(1) LOW TEMPERATURE

Water low temperature(B)

this version permits units operation with glycol solution temperature from +5°C to -8°C.

Water low temperature source side(BS)

Prarrangement for use of source side water, with temperature conditions lower than +5°C.

(2) VOLTAGE

Supply voltage 400/3/50+N(400TN)

From size 17 to 31: optional

From size 41 to 121: standard

Supply voltage 230/1/50(230M)

From size 17 to 31: standard

only size 41 optional

(3) OPERATION

Operation only cooling(OCO) standard

Operation with reversal on water circuit(OHI)

(4) HYDRONIC GROUP UTILITY SIDE

hydronic group utility side(HYGU) standard

Hydronic group utility side: not required(-)

(5) HYDRONIC GROUP SOURCE SIDE

Hydronic group source side: not required(-)standard

hydronic group source side(HYGS)

Configuration not available for sizes 101 and 121

(6) SOFT STARTER

Disposal for inrush current reduction: not required(-) standard

Disposal for inrush current reduction(SFSTR)

(7) 3-WAY VALVE

Three-way valve: not required(-) standard

three-way valve(3WV)

for sanitary hot water

Application: Terminal units

GENERAL TECHNICAL SPECIFICATIONS

Size		17	21	31	41	51	61	71	81	91	101	121
COOLING												
Cooling capacity	1 kW	5,95	6,42	7,9	10,5	13,4	16,7	20,2	22,1	25,8	30,5	35
Compressor power input	1 kW	1,51	1,64	1,95	2,4	3,15	3,78	4,82	5,02	5,88	6,56	7,55
Total power input	2 kW	1,52	1,65	1,96	2,41	3,16	3,79	4,83	5,03	5,89	6,57	7,56
EER		3,91	3,89	4,03	4,36	4,24	4,41	4,18	4,39	4,38	4,64	4,63
ESEER		4,29	4,25	4,54	4,84	4,48	4,7	4,59	4,92	4,86	5,13	5,04
HEATING												
Heat output	3 kW	7	7,63	9,28	12	15,6	19,1	23,4	25,1	29,5	34,3	39,3
Compressor power input	kW	1,89	2,06	2,53	3,02	4,12	4,62	5,9	6,39	7,21	8,17	9,22
Total power input	2 kW	1,9	2,07	2,54	3,03	4,13	4,63	5,91	6,4	7,22	8,18	9,23
COP		3,68	3,69	3,65	3,96	3,78	4,13	3,96	3,92	4,09	4,19	4,26
COMPRESSOR												
Type of compressors		SCROLL	SCROLL	SCROLL	SCROLL	SCROLL	SCROLL	SCROLL	SCROLL	SCROLL	SCROLL	SCROLL
No. of Compressors	Nr	1	1	1	1	1	1	1	1	1	1	1
Std Capacity control steps	Nr	1	1	1	1	1	1	1	1	1	1	1
Refrigerant charge (C1)	kg	0,8	0,8	0,9	1,1	1,6	1,7	2,4	2,7	3	3,3	3,6
Refrigerant circuits	Nr	1	1	1	1	1	1	1	1	1	1	1
INTERNAL EXCHANGER												
Type of internal exchanger	4	PHE	PHE	PHE	PHE	PHE	PHE	PHE	PHE	PHE	PHE	PHE
No. of internal exchangers	Nr	1	1	1	1	1	1	1	1	1	1	1
Water flow rate (Internal Exchanger)	1 l/s	0,28	0,31	0,38	0,5	0,64	0,8	0,97	1,06	1,23	1,46	1,67
Useful pump discharge head	1 kPa	56.0	54.1	53.3	43.4	37.8	59.6	55.1	49.5	43.8	143.5	112.1
Water content	l	0,6	0,6	0,8	0,8	0,9	1,1	2,2	2,5	2,9	2,9	3,2
EXTERNAL EXCHANGER												
type of external exchanger	4	PHE	PHE	PHE	PHE	PHE	PHE	PHE	PHE	PHE	PHE	PHE
Water flow rate (Exetrnal Exchanger)	1 l/s	0,36	0,39	0,47	0,62	0,79	0,98	1,2	1,3	1,51	1,77	2,03
external exchanger pressure drop	kPa	15	17	16	24	28	29	33	29,5	29,7	39,3	42,5
Quantity	Nr	1	1	1	1	1	1	1	1	1	1	1
CONNECTIONS												
Water fittings	5	1"GAS F	1"GAS F	1"GAS F	1"GAS F	1"GAS F	1"GAS F	1"GAS F	1"GAS F	1"GAS F	1"GAS F	1"GAS F
HYDRAULIC CIRCUIT												
Max water side pressure	kPa	550	550	550	550	550	550	550	550	550	550	550
Safety valve calibration	kPa	600	600	600	600	600	600	600	600	600	600	600
EXPANSION VESSEL												
Expansion vessel capacity	l	1	1	1	1	2	2	2	2	2	2	2
No. of expansion vessels	Nr	1	1	1	1	1	1	1	1	1	1	1
POWER SUPPLY												
Standard power supply	V	230/1/50	230/1/50	230/1/50	400/3/50+N	400/3/50+N	400/3/50+N	400/3/50+N	400/3/50+N	400/3/50+N	400/3/50+N	400/3/50+N
NOISE LEVELS												
Sound pressure level (1 m)	dB(A)	43	43	44	44	45	46	49	50	51	52	53
DIMENSIONS												
Length	mm	402	402	402	402	402	573	573	573	573	573	573
Depth	mm	602	602	602	602	602	604	604	604	604	604	604
Height	mm	785	785	785	785	785	858	858	858	858	858	858
STANDARD UNIT WEIGHTS												
Shipping weight	kg	78	79	83	85	99	111	125	140	153	155	160
Operating weight	kg	80	81	85	88	102	114	128	143	157	159	164

(1) data referred to the following conditions :

internal exchanger water = 12/7°C

external exchanger water = 30/35°C

(2) The total absorbed power is obtained adding the compressors absorbed power + the power absorbed by the auxiliary circuit.

(3) data referred to the following conditions :

WATER TO INTERNAL EXCHANGER 40/45°C

External exchanger inlet water = 10°C

The water flow in the external exchanger is the same of the cooling operation.

(4) PHE = plates

(5) water connections both source side and utility side

Application: Unit for radiant panels

GENERAL TECHNICAL SPECIFICATIONS

Size		17	21	31	41	51	61	71	81	91	101	121
COOLING												
Cooling capacity	1 kW	8,34	8,95	10,1	14	18,3	22,5	26,1	30	33,4	41,8	47,5
Compressor power input	1 kW	1,46	1,48	1,85	2,32	2,97	3,94	4,97	5,09	5,99	6,64	7,95
Total power input	2 kW	1,47	1,49	1,86	2,33	2,98	3,95	4,98	5,1	6	6,65	7,96
EER		5,67	6,01	5,43	6,01	6,14	5,7	5,24	5,88	5,57	6,29	5,97
HEATING												
Heat output	3 kW	7,27	7,85	9,59	12,6	16,2	19,9	24,4	26,4	30,9	36,1	41,4
Compressor power input	kW	1,51	1,64	1,95	2,39	3,14	3,76	4,79	5	5,85	6,53	7,53
Total power input	2 kW	1,52	1,65	1,96	2,4	3,15	3,77	4,8	5,01	5,86	6,54	7,54
COP		4,78	4,76	4,89	5,25	5,14	5,28	5,08	5,27	5,27	5,52	5,49
COMPRESSOR												
Type of compressors		SCROLL	SCROLL	SCROLL	SCROLL	SCROLL	SCROLL	SCROLL	SCROLL	SCROLL	SCROLL	SCROLL
No. of Compressors	Nr	1	1	1	1	1	1	1	1	1	1	1
Std Capacity control steps	Nr	1	1	1	1	1	1	1	1	1	1	1
Refrigerant charge (C1)	kg	0,8	0,8	0,9	1,1	1,6	1,7	2,4	2,7	3	3,3	3,6
Refrigerant circuits	Nr	1	1	1	1	1	1	1	1	1	1	1
INTERNAL EXCHANGER												
Type of internal exchanger	4	PHE	PHE	PHE	PHE	PHE	PHE	PHE	PHE	PHE	PHE	PHE
No. of internal exchangers	Nr	1	1	1	1	1	1	1	1	1	1	1
Water flow rate (Internal Exchanger)	1 l/s	0,4	0,43	0,48	0,67	0,87	1,08	1,25	1,43	1,6	2	2,27
Useful pump discharge head	1 kPa	45,5	42,5	45,0	27,3	17,8	38,6	33,7	22,8	18,6	37,5	15,0
Water content	l	0,6	0,6	0,8	0,8	0,9	1,1	2,2	2,5	2,9	2,9	3,2
EXTERNAL EXCHANGER												
type of external exchanger	4	PHE	PHE	PHE	PHE	PHE	PHE	PHE	PHE	PHE	PHE	PHE
Water flow rate (Exetrnal Exchanger)	l/s	0,47	0,5	0,57	0,78	1,02	1,26	1,48	1,68	1,88	2,31	2,65
Max water flow-rate	l/s	0,78	0,83	0,95	1,3	1,69	2,11	2,47	2,79	3,14	3,86	4,42
external exchanger pressure drop	kPa	18	20	18	31	31	36	42	38	38	49	53,4
Quantity	Nr	1	1	1	1	1	1	1	1	1	1	1
CONNECTIONS												
Water fittings	5	1" GAS F	1" GAS F	1" GAS F	1" GAS F	1" GAS F	1" GAS F	1" GAS F	1" GAS F	1" GAS F	1" GAS F	1" GAS F
HYDRAULIC CIRCUIT												
Max water side pressure	kPa	550	550	550	550	550	550	550	550	550	550	550
Safety valve calibration	kPa	600	600	600	600	600	600	600	600	600	600	600
EXPANSION VESSEL												
Expansion vessel capacity	l	1	1	1	1	2	2	2	2	2	2	2
No. of expansion vessels	Nr	1	1	1	1	1	1	1	1	1	1	1
POWER SUPPLY												
Standard power supply	V	230/1/50	230/1/50	230/1/50	400/3/50+N	400/3/50+N	400/3/50+N	400/3/50+N	400/3/50+N	400/3/50+N	400/3/50+N	400/3/50+N
NOISE LEVELS												
Sound pressure level (1 m)	dB(A)	43	43	44	44	45	46	49	50	51	52	53
DIMENSIONS												
Length	mm	402	402	402	402	402	573	573	573	573	573	573
Depth	mm	602	602	602	602	602	604	604	604	604	604	604
Height	mm	785	785	785	785	785	858	858	858	858	858	858
STANDARD UNIT WEIGHTS												
Shipping weight	kg	78	79	83	85	99	111	125	140	153	155	160
Operating weight	kg	80	81	85	88	102	114	128	143	157	159	164

(1) data referred to the following conditions :

external exchanger water = 30/35°C

internal exchanger water = 23/18°C

(2) The total absorbed power is obtained adding the compressors absorbed power + the

power absorbed by the auxiliary circuit.

(3) data referred to the following conditions :

WATER TO INTERNAL EXCHANGER 40/45°C

External exchanger inlet water = 10°C

The water flow in the external exchanger is the same of the cooling operation.

(4) PHE = plates

(5) water connections both source side and utility side

UNIT PERFORMANCES FOR GEOTHERMAL SYSTEM

GR.		17		21		31		41		51		61		71		81		91		101		121	
		W35	W50	W35	W50	W35	W50	W35	W50	W35	W50	W35	W50	W35	W50	W35	W50	W35	W50	W35	W50	W35	W50
kWt (kW)	B0	5.41	5.22	5.95	5.89	7.42	7.34	9.32	8.83	14.2	13.7	14.8	13.8	18.0	17.1	19.8	18.7	22.7	21.4	25.9	24.4	29.2	28.1
kWe (kW)	B0	1.44	2.12	1.61	2.41	1.89	3.05	2.28	3.43	3.15	4.70	3.62	5.41	4.32	6.42	4.80	6.99	5.40	7.88	6.35	9.34	7.42	10.7
kWf (kW)	B0	3.96	3.10	4.35	3.48	5.54	4.29	7.04	5.40	11.1	9.00	11.2	8.40	13.7	10.7	15.0	11.7	17.2	13.5	19.6	15.1	21.8	17.4
COP		3.73	2.45	3.67	2.43	3.91	2.40	4.07	2.57	4.51	2.91	4.08	2.55	4.16	2.66	4.12	2.67	4.19	2.71	4.07	2.61	3.93	2.62
kWt (kW)	W10	7.30	6.80	7.70	7.30	9.90	9.30	12.4	11.5	16.0	15.2	19.7	18.3	24.4	22.7	26.8	24.7	30.8	28.6	35.0	32.1	39.6	35.5
kWe (kW)	W10	1.46	2.08	1.59	2.30	1.86	2.77	2.37	3.36	3.19	4.60	3.83	5.35	4.60	6.45	4.93	7.03	5.64	7.77	6.60	9.33	7.69	10.6
kWf (kW)	W10	5.81	4.68	6.13	5.02	8.02	6.52	10.0	8.1	12.8	10.6	15.9	12.9	19.8	16.2	21.9	17.7	25.2	20.8	28.4	22.8	31.9	24.9
COP		4.97	3.25	4.81	3.16	5.29	3.35	5.21	3.41	5.00	3.30	5.13	3.41	5.29	3.51	5.43	3.51	5.45	3.68	5.30	3.44	5.14	3.35

KWT = HEATING CAPACITY (KW)
 KWF = COOLING CAPACITY IN KW
 KWE = TOTAL POWER INPUT (KW)
 B0= EXTERNAL EXCHANGER INLET WATER TEMPERATURE 0°C
 W10= EXTERNAL EXCHANGER INLET WATER TEMPERATURE 10°C
 W35 = TEMPERATURE WATER FROM INTERNAL EXCHANGER 35°C
 W50 = TEMPERATURE WATER FROM THE INTERNAL EXCHANGER 50°C
 EXTERNAL EXCHANGER = UTILITY SIDE EXCHANGER
 INTERNAL EXCHANGER = SOURCE SIDE EXCHANGER

Voltage: 230/1/50

ELECTRICAL DATA

Size		17	21	31	41
------	--	----	----	----	----

F.L.A. - FULL LOAD CURRENT AT MAX ADMISSIBLE CONDITIONS

F.L.A. - Pump	A	0,95	0,95	0,95	0,95
F.L.A. - Total	A	13,85	14,75	18,48	23,15

F.L.I. FULL LOAD POWER INPUT AT MAX ADMISSIBLE CONDITION

F.L.I. - Pump	kW	0,2	0,2	0,2	0,2
F.L.I. - Total	kW	2,97	3,25	4,05	4,99

M.I.C. MAXIMUM INRUSH CURRENT

M.I.C. - Value	A	58,95	61,95	82,95	98,02
----------------	---	-------	-------	-------	-------

power supply 230/1/50 Hz +/-6%

Voltage: 400/3/50+N

ELECTRICAL DATA

Size		17	21	31	41	51	61	71	81	91	101	121
------	--	----	----	----	----	----	----	----	----	----	-----	-----

F.L.A. - FULL LOAD CURRENT AT MAX ADMISSIBLE CONDITIONS

F.L.A. - Pump	A	0,95	0,95	0,95	0,95	0,95	2,02	2,02	2,02	2,02	3,81	3,81
F.L.A. - Total	A	5,35	5,75	7,85	8,55	11,25	13,22	16,32	17,52	18,52	24,51	26,61

F.L.I. FULL LOAD POWER INPUT AT MAX ADMISSIBLE CONDITION

F.L.I. - Pump	kW	0,2	0,2	0,2	0,2	0,2	0,4	0,4	0,4	0,4	0,55	0,55
F.L.I. - Total	kW	2,98	3,29	3,83	4,54	6,3	7,05	8,7	9,5	10,6	12,55	13,95

M.I.C. MAXIMUM INRUSH CURRENT

M.I.C. - Value	A	27	33	36	49	65	76	103	97	113	120	120
----------------	---	----	----	----	----	----	----	-----	----	-----	-----	-----

power supply 400/3/50 (+ NEUTRAL) +/- 6%
 Maximum Phase Unbalance: 2%

PUMP PERFORMANCE

PUMP PERFORMANCE(1)

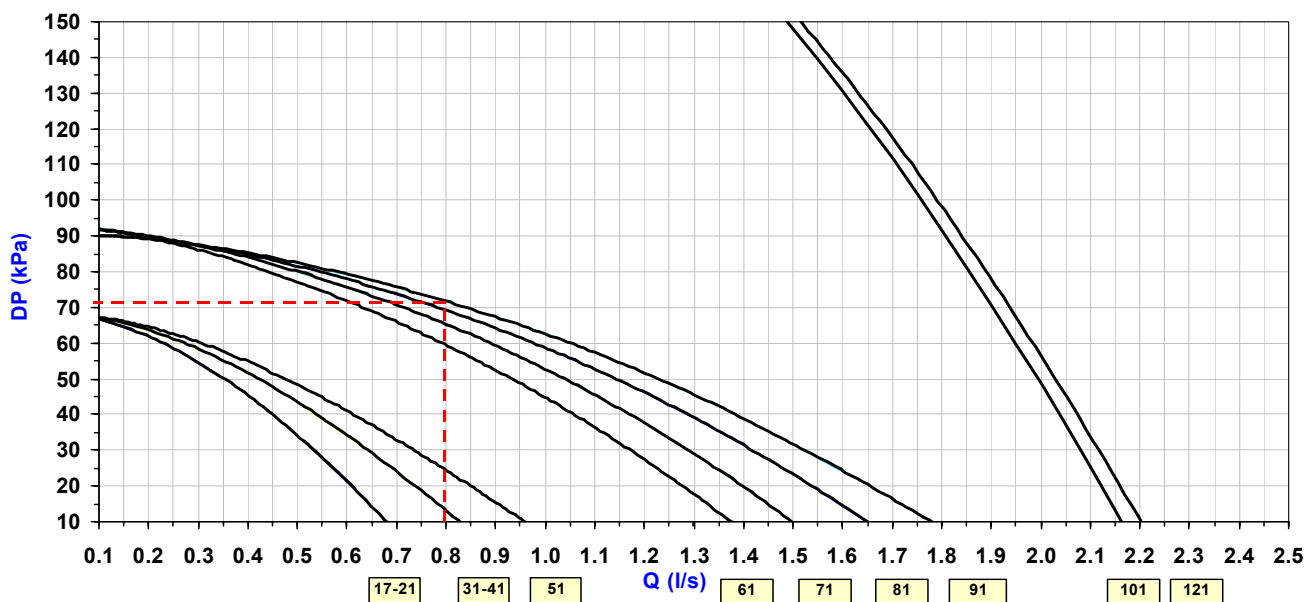

UTILITY SIDE PUMP (STANDARD)
 Q[L/S]= WATER-FLOW RATE
 DP[KPA]=USEFUL DISCHARGE HEAD
 THE HEADS ARE INTENDED AS AVAILABLE AT THE UNIT CONNECTIONS

APPLICATION: TERMINAL UNITS

OPERATING LIMITS (COOLING)

Size			17	21	31	41	51	61	71	81	91	101	121
EXTERNAL EXCHANGER													
Min. water inlet temperature	1	°C	15	15	15	15	15	15	15	15	15	15	15
Min. water inlet temperature	2	°C	6	6	6	6	6	6	6	6	6	6	6
Max water outlet temperature	1	°C	55	55	55	55	55	55	55	55	55	55	55
Min. water outlet temperature		°C	28	28	28	28	28	28	28	28	28	28	28
Water thermal head (min / max)		°C	5 / 16	5 / 16	5 / 16	5 / 16	5 / 16	5 / 16	5 / 16	5 / 16	5 / 16	5 / 16	5 / 16
INTERNAL EXCHANGER													
Max water inlet temperature		°C	24	24	24	24	24	24	24	24	24	24	24
Max water outlet temperature		°C	18	18	18	18	18	18	18	18	18	18	18
Min. water outlet temperature	3	°C	5	5	5	5	5	5	5	5	5	5	5
Water thermal head (min / max)		°C	3 / 8	3 / 8	3 / 8	3 / 8	3 / 8	3 / 8	3 / 8	3 / 8	3 / 8	3 / 8	3 / 8

OPERATING LIMITS (HEATING)

EXTERNAL EXCHANGER													
Max water outlet temperature		°C	18	18	18	18	18	18	18	18	18	18	18
Min. water outlet temperature	3	°C	5	5	5	5	5	5	5	5	5	5	5
INTERNAL EXCHANGER													
Max water outlet temperature	4	°C	55	55	55	55	55	55	55	55	55	55	55
Water thermal head (min / max)		°C	3 / 8	3 / 8	3 / 8	3 / 8	3 / 8	3 / 8	3 / 8	3 / 8	3 / 8	3 / 8	3 / 8

internal exchanger = source side exchanger
 external exchanger = utility side exchanger

- (1) standard unit
- (2) The limit is referred to the use of a modulating or pressostatic valve, at the external exchanger inlet.
- (3) antifreeze set-point
- (4) External exchanger inlet water = 10°C

BT06G008GB-02

SOUND LEVELS

Size	Sound Power Level (dB)								Sound pressure level	Sound power level
	Octave band (Hz)									
	63	125	250	500	1000	2000	4000	8000	dB(A)	dB(A)
17	78	69	55	46	47	40	34	29	43	57
21	78	69	56	48	47	38	35	32	43	57
31	79	67	57	51	49	41	41	35	44	57
41	78	70	59	50	47	43	38	34	44	58
51	77	69	61	54	49	41	39	36	45	58
61	78	67	62	55	54	46	43	38	46	60
71	77	72	65	62	53	47	44	38	49	63
81	78	73	66	63	54	48	45	39	50	64
91	81	68	68	65	56	52	49	45	51	65
101	79	75	68	63	56	55	49	44	52	66
121	80	74	70	65	58	55	51	45	53	67

Measures according to ISO 3744 regulations, with respect to the EUROVENT 8/1 certification.
The sound pressure is measured at 1 m from the external surface of the unit in open field conditions.
data referred to the following conditions :
internal exchanger water = 12/7°C
external exchanger water = 30/35°C

CORRECTION FACTOR FOR ANTIFREEZE SOLUTIONS

% ethylene glycol by weight		5%	10%	15%	20%	25%	30%	35%	40%
Freezing temperature	°C	-2,0	-3,9	-6,5	-8,9	-11,8	-15,6	-19,0	-23,4
Safety temperature	°C	3,0	1,0	-1,0	-4,0	-6,0	-10,0	-14,0	-19,0
Cooling Capacity Factor	Nr	0,995	0,990	0,985	0,981	0,977	0,974	0,971	0,968
Compressor input Factor	Nr	0,997	0,993	0,990	0,988	0,986	0,984	0,982	0,981
Internal exchanger Glycol solution flow Factor	Nr	1,003	1,010	1,020	1,033	1,050	1,072	1,095	1,124
Pressure drop Factor	Nr	1,029	1,060	1,090	1,118	1,149	1,182	1,211	1,243

The correction factors shown refer to water and glycol ethylene mixes used to prevent the formation of frost on the exchangers in the water circuit during inactivity in winter.
The correction factors are used both for the utility and for the source side.

FOULING CORRECTION FACTOR

m ² °C/W	INTERNAL EXCHANGER		EXTERNAL EXCHANGER	
	F1	FK1	F2	FK2
0.44 x 10 ⁻⁴	1,00	1,00	1,00	1,00
0.88 x 10 ⁻⁴	0,97	0,99	0,97	1,08
1.76 x 10 ⁻⁴	0,94	0,98	0,92	1,05

The cooling performance values provided in the tables are based on the external exchanger having clean plates (fouling factor 1). For different fouling factor values, multiply the performance by the coefficients shown in the table.

F1 = Cooling capacity correction factors

FK1 = Compressor power input correction factor

F2 = Cooling capacity correction factors

FK2 = Compressors input power correction factors

HYDRONIC
17 - 121

EXCHANGER PRESSURE DROPS

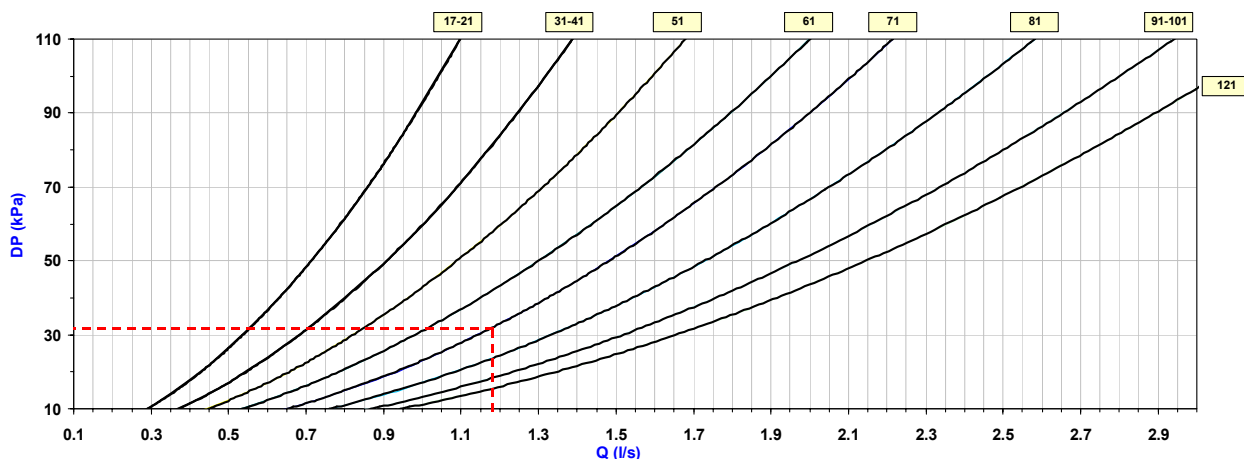

Q[L/S]= WATER-FLOW RATE
DP = PRESSURE DROP
THE DATA ARE REFERRED BOTH TO INTERNAL AND EXTERNAL EXCHANGER, AS EQUAL.

internal exchanger pressure drop

SIZE		17	21	31	41	51	61	71	81	91	101	121
Minimal flow	[l/s]	0.29	0.29	0.37	0.37	0.45	0.54	0.65	0.76	0.87	0.87	0.95
Maximum flow	[l/s]	1.10	1.10	1.35	1.35	1.66	1.97	2.20	2.56	2.93	2.93	3.20

external exchanger pressure drop

SIZE		17	21	31	41	51	61	71	81	91	101	121
Minimal flow	[l/s]	0.1	0.1	0.2	0.2	0.2	0.2	0.2	0.2	0.3	0.3	0.3
Maximum flow	[l/s]	1.10	1.10	1.35	1.35	1.66	1.97	2.20	2.56	2.93	2.93	3.20

BT06G008GB-02

APPLICATION: TERMINAL UNITS

PERFORMANCES IN COOLING AND IN HEATING

Size	To (°C)	OUTLET WATER TEMPERATURE (1)(°C)																	
		30			35			40			45			50			55		
		kWf	kWe	kWt	kWf	kWe	kWt	kWf	kWe	kWt	kWf	kWe	kWt	kWf	kWe	kWt	kWf	kWe	kWt
17	6	6,00	1,37	7,4	5,75	1,51	7,3	5,46	1,68	7,1	5,11	1,89	7,0	4,70	2,13	6,8	4,25	2,40	6,7
	7	6,20	1,38	7,6	5,95	1,51	7,5	5,65	1,68	7,3	5,29	1,89	7,2	4,87	2,12	7,0	4,41	2,39	6,8
	8	6,41	1,38	7,8	6,15	1,52	7,7	5,84	1,69	7,5	5,47	1,89	7,4	5,05	2,12	7,2	4,57	2,39	7,0
	9	6,63	1,38	8,0	6,36	1,52	7,9	6,04	1,69	7,7	5,66	1,89	7,6	5,23	2,12	7,4	4,74	2,39	7,1
	10	6,85	1,38	8,2	6,57	1,52	8,1	6,24	1,69	7,9	5,85	1,89	7,7	5,41	2,12	7,5	4,91	2,38	7,3
	11	7,07	1,38	8,5	6,79	1,52	8,3	6,44	1,69	8,1	6,05	1,89	7,9	5,59	2,12	7,7	5,09	2,38	7,5
21	6	6,46	1,48	7,9	6,21	1,64	7,9	5,91	1,84	7,8	5,56	2,08	7,6	5,15	2,36	7,5	4,69	2,68	7,4
	7	6,67	1,48	8,2	6,42	1,64	8,1	6,11	1,83	7,9	5,74	2,07	7,8	5,33	2,35	7,7	4,86	2,67	7,5
	8	6,89	1,48	8,4	6,62	1,64	8,3	6,31	1,83	8,1	5,94	2,07	8,0	5,51	2,35	7,9	5,03	2,67	7,7
	9	7,11	1,48	8,6	6,84	1,63	8,5	6,51	1,83	8,3	6,13	2,07	8,2	5,69	2,34	8,0	5,20	2,66	7,9
	10	7,34	1,48	8,8	7,06	1,63	8,7	6,72	1,83	8,6	6,33	2,07	8,4	5,88	2,34	8,2	5,38	2,66	8,0
	11	7,57	1,48	9,1	7,28	1,63	8,9	6,93	1,83	8,8	6,53	2,06	8,6	6,08	2,34	8,4	5,57	2,65	8,2
31	6	8,04	1,73	9,8	7,64	1,95	9,6	7,21	2,22	9,4	6,75	2,53	9,3	6,25	2,90	9,2	5,72	3,31	9,0
	7	8,30	1,73	10,0	7,90	1,95	9,9	7,45	2,21	9,7	6,98	2,53	9,5	6,47	2,89	9,4	5,92	3,30	9,2
	8	8,58	1,72	10,3	8,16	1,95	10,1	7,71	2,21	9,9	7,22	2,53	9,8	6,70	2,89	9,6	6,14	3,29	9,4
	9	8,86	1,72	10,6	8,43	1,94	10,4	7,97	2,21	10,2	7,47	2,52	10,0	6,93	2,88	9,8	6,36	3,28	9,6
	10	9,16	1,72	10,9	8,72	1,94	10,7	8,24	2,21	10,5	7,73	2,52	10,3	7,18	2,87	10,1	6,59	3,28	9,9
	11	9,46	1,72	11,2	9,01	1,94	11,0	8,52	2,21	10,7	8,00	2,52	10,5	7,43	2,87	10,3	6,83	3,27	10,1
41	6	10,7	2,14	12,8	10,2	2,39	12,6	9,62	2,69	12,3	9,00	3,02	12,0	8,35	3,39	11,7	7,65	3,80	11,5
	7	11,1	2,14	13,2	10,5	2,40	12,9	9,93	2,70	12,6	9,30	3,03	12,3	8,63	3,40	12,0	7,91	3,81	11,7
	8	11,4	2,15	13,6	10,9	2,41	13,3	10,3	2,70	13,0	9,61	3,03	12,6	8,92	3,41	12,3	8,19	3,81	12,0
	9	11,8	2,15	14,0	11,2	2,41	13,6	10,6	2,71	13,3	9,93	3,04	13,0	9,22	3,41	12,6	8,47	3,82	12,3
	10	12,2	2,16	14,4	11,6	2,42	14,0	10,9	2,71	13,6	10,3	3,05	13,4	9,54	3,42	13,0	8,77	3,82	12,6
	11	12,6	2,16	14,8	12,0	2,42	14,4	11,3	2,72	14,0	10,6	3,05	13,7	9,86	3,42	13,3	9,08	3,83	12,9
51	6	13,6	2,82	16,4	13,0	3,14	16,1	12,3	3,57	15,9	11,5	4,12	15,6	10,4	4,78	15,2	9,23	5,55	14,8
	7	14,0	2,83	16,8	13,4	3,15	16,6	12,7	3,58	16,3	11,8	4,12	15,9	10,8	4,77	15,6	9,55	5,53	15,1
	8	14,4	2,84	17,2	13,8	3,16	17,0	13,1	3,59	16,7	12,2	4,12	16,3	11,1	4,77	15,9	9,88	5,52	15,4
	9	14,9	2,86	17,8	14,3	3,17	17,5	13,5	3,59	17,1	12,6	4,12	16,7	11,5	4,76	16,3	10,2	5,51	15,7
	10	15,3	2,87	18,2	14,7	3,18	17,9	13,9	3,60	17,5	13,0	4,13	17,1	11,9	4,76	16,7	10,6	5,49	16,1
	11	15,8	2,88	18,7	15,2	3,20	18,4	14,4	3,61	18,0	13,4	4,13	17,5	12,3	4,76	17,1	10,9	5,48	16,4
61	6	16,8	3,45	20,3	16,2	3,76	20,0	15,4	4,15	19,6	14,4	4,62	19,0	13,4	5,17	18,6	12,2	5,81	18,0
	7	17,3	3,46	20,8	16,7	3,78	20,5	15,9	4,17	20,1	14,9	4,64	19,5	13,8	5,19	19,0	12,6	5,82	18,4
	8	17,9	3,48	21,4	17,2	3,79	21,0	16,3	4,18	20,5	15,4	4,66	20,1	14,3	5,20	19,5	13,0	5,83	18,8
	9	18,5	3,49	22,0	17,7	3,81	21,5	16,9	4,20	21,1	15,9	4,67	20,6	14,7	5,22	19,9	13,4	5,84	19,2
	10	19,1	3,51	22,6	18,3	3,82	22,1	17,4	4,22	21,6	16,4	4,69	21,1	15,2	5,23	20,4	13,9	5,85	19,8
	11	19,7	3,52	23,2	18,9	3,84	22,7	18,0	4,23	22,2	16,9	4,70	21,6	15,7	5,24	20,9	14,4	5,86	20,3
	12	20,3	3,54	23,8	19,6	3,86	23,5	18,6	4,25	22,9	17,5	4,71	22,2	16,3	5,25	21,6	14,9	5,87	20,8

kWf = Cooling capacity in kW
kWe = Compressor power input in kW
kWt = heating capacity (kW)

To = Temperature of outlet water to evaporator (Cooling) or to condenser (Heating) (°C)
(1) Condenser outlet water temperature, in cooling operation.
(1) Evaporator outlet water temperature, in heating operation.

APPLICATION: TERMINAL UNITS

PERFORMANCES IN COOLING AND IN HEATING

Size	To (°C)	OUTLET WATER TEMPERATURE (1)(°C)																	
		30			35			40			45			50			55		
		kWf	kWe	kWt	kWf	kWe	kWt	kWf	kWe	kWt	kWf	kWe	kWt	kWf	kWe	kWt	kWf	kWe	kWt
71	6	20,7	4,27	25,0	19,9	4,67	24,6	18,9	5,18	24,1	17,8	5,80	23,6	16,5	6,51	23,0	15,0	7,33	22,3
	7	21,4	4,29	25,7	20,5	4,70	25,2	19,5	5,21	24,7	18,3	5,82	24,1	17,0	6,53	23,5	15,5	7,35	22,9
	8	22,0	4,32	26,3	21,1	4,73	25,8	20,1	5,23	25,3	18,9	5,84	24,7	17,5	6,56	24,1	16,0	7,37	23,4
	9	22,6	4,34	26,9	21,7	4,75	26,5	20,7	5,26	26,0	19,4	5,87	25,3	18,0	6,58	24,6	16,5	7,39	23,9
	10	23,2	4,37	27,6	22,3	4,78	27,1	21,2	5,28	26,5	20,0	5,89	25,9	18,6	6,60	25,2	16,9	7,41	24,3
	11	23,8	4,39	28,2	22,9	4,80	27,7	21,8	5,31	27,1	20,5	5,91	26,4	19,1	6,62	25,7	17,4	7,43	24,8
	12	24,4	4,42	28,8	23,5	4,82	28,3	22,3	5,33	27,6	21,0	5,93	26,9	19,5	6,64	26,1	17,9	7,45	25,4
81	6	22,6	4,40	27,0	21,4	5,00	26,4	20,1	5,66	25,8	18,7	6,39	25,1	17,2	7,20	24,4	15,7	8,07	23,8
	7	23,3	4,42	27,7	22,1	5,02	27,1	20,8	5,68	26,5	19,3	6,41	25,7	17,8	7,20	25,0	16,2	8,07	24,3
	8	24,0	4,45	28,5	22,8	5,04	27,8	21,4	5,69	27,1	20,0	6,42	26,4	18,4	7,21	25,6	16,8	8,07	24,9
	9	24,7	4,47	29,2	23,5	5,06	28,6	22,1	5,71	27,8	20,7	6,43	27,1	19,1	7,21	26,3	17,4	8,06	25,5
	10	25,4	4,49	29,9	24,2	5,08	29,3	22,8	5,73	28,5	21,3	6,44	27,7	19,7	7,22	26,9	17,9	8,06	26,0
	11	26,2	4,52	30,7	24,9	5,10	30,0	23,6	5,75	29,4	22,0	6,46	28,5	20,3	7,23	27,5	18,5	8,06	26,6
	12	26,9	4,55	31,5	25,7	5,13	30,8	24,3	5,77	30,1	22,7	6,47	29,2	21,0	7,23	28,2	19,1	8,05	27,2
91	6	26,3	5,29	31,6	25,0	5,85	30,9	23,7	6,49	30,2	22,3	7,21	29,5	20,9	8,01	28,9	19,3	8,88	28,2
	7	27,1	5,31	32,4	25,8	5,88	31,7	24,5	6,52	31,0	23,1	7,23	30,3	21,6	8,03	29,6	20,1	8,89	29,0
	8	28,0	5,34	33,3	26,6	5,90	32,5	25,2	6,54	31,7	23,8	7,26	31,1	22,3	8,05	30,4	20,8	8,92	29,7
	9	28,8	5,36	34,2	27,4	5,93	33,3	26,0	6,57	32,6	24,6	7,28	31,9	23,1	8,08	31,2	21,5	8,95	30,5
	10	29,7	5,39	35,1	28,3	5,95	34,3	26,8	6,59	33,4	25,4	7,31	32,7	23,9	8,11	32,0	22,3	8,99	31,3
	11	30,6	5,42	36,0	29,1	5,98	35,1	27,7	6,62	34,3	26,2	7,35	33,6	24,6	8,15	32,8	23,1	9,03	32,1
	12	31,5	5,45	37,0	30,0	6,01	36,0	28,5	6,66	35,2	27,0	7,38	34,4	25,4	8,19	33,6	23,9	9,08	33,0
101	6	31,0	5,88	36,9	29,6	6,53	36,1	28,0	7,30	35,3	26,1	8,17	34,3	24,1	9,16	33,3	21,8	10,3	32,1
	7	31,9	5,90	37,8	30,5	6,56	37,1	28,9	7,32	36,2	27,0	8,19	35,2	24,9	9,18	34,1	22,6	10,3	32,9
	8	32,9	5,93	38,8	31,4	6,58	38,0	29,8	7,34	37,1	27,9	8,21	36,1	25,7	9,19	34,9	23,4	10,3	33,7
	9	33,8	5,96	39,8	32,4	6,61	39,0	30,7	7,37	38,1	28,8	8,24	37,0	26,6	9,21	35,8	24,2	10,3	34,5
	10	34,9	5,99	40,9	33,4	6,64	40,0	31,7	7,39	39,1	29,7	8,26	38,0	27,5	9,24	36,7	25,0	10,3	35,3
	11	35,9	6,02	41,9	34,4	6,66	41,1	32,6	7,42	40,0	30,6	8,29	38,9	28,4	9,26	37,7	25,9	10,3	36,2
	12	36,9	6,05	43,0	35,4	6,69	42,1	33,6	7,45	41,1	31,6	8,31	39,9	29,3	9,28	38,6	26,8	10,4	37,2
121	6	35,4	6,87	42,3	33,9	7,53	41,4	32,1	8,31	40,4	30,1	9,22	39,3	27,7	10,3	38,0	25,1	11,4	36,5
	7	36,6	6,90	43,5	35,0	7,55	42,6	33,2	8,33	41,5	31,0	9,24	40,2	28,6	10,3	38,9	25,9	11,4	37,3
	8	37,7	6,93	44,6	36,1	7,58	43,7	34,2	8,36	42,6	32,0	9,26	41,3	29,5	10,3	39,8	26,7	11,5	38,2
	9	38,9	6,97	45,9	37,3	7,61	44,9	35,3	8,38	43,7	33,0	9,28	42,3	30,4	10,3	40,7	27,5	11,5	39,0
	10	40,1	7,00	47,1	38,4	7,64	46,0	36,4	8,41	44,8	34,0	9,30	43,3	31,3	10,3	41,6	28,3	11,5	39,8
	11	41,4	7,04	48,4	39,6	7,68	47,3	37,5	8,44	45,9	35,1	9,33	44,4	32,3	10,3	42,6	29,1	11,5	40,6
	12	42,6	7,07	49,7	40,8	7,71	48,5	38,7	8,47	47,2	36,2	9,35	45,6	33,2	10,4	43,6	30,0	11,5	41,5

kWf = Cooling capacity in kW
 kWe = Compressor power input in kW
 kWt = heating capacity (kW)
 To = Temperature of outlet water to evaporator (Cooling) or to condenser (Heating) (°C)
 (1) Condenser outlet water temperature, in cooling operation.
 (1) Evaporator outlet water temperature, in heating operation.

APPLICATION: UNIT FOR RADIANT PANELS

PERFORMANCES IN COOLING AND IN HEATING

Size	To (°C)	OUTLET WATER TEMPERATURE (1)(°C)																	
		30			33			35			40			45			50		
		kWf	kWe	kWt	kWf	kWe	kWt	kWf	kWe	kWt	kWf	kWe	kWt	kWf	kWe	kWt	kWf	kWe	kWt
17	13	7,53	1,32	8,9	7,34	1,40	8,7	7,21	1,46	8,7	6,85	1,63	8,5	6,43	1,82	8,3	5,97	2,04	8,0
	14	7,76	1,32	9,1	7,57	1,40	9,0	7,43	1,46	8,9	7,06	1,63	8,7	6,63	1,82	8,5	6,16	2,04	8,2
	15	7,99	1,32	9,3	7,80	1,40	9,2	7,66	1,46	9,1	7,27	1,63	8,9	6,84	1,82	8,7	6,35	2,03	8,4
	16	8,23	1,32	9,5	8,03	1,40	9,4	7,88	1,46	9,3	7,49	1,63	9,1	7,04	1,82	8,9	6,55	2,03	8,6
	17	8,47	1,32	9,8	8,26	1,40	9,7	8,11	1,46	9,6	7,71	1,63	9,3	7,25	1,81	9,1	6,75	2,03	8,8
	18	8,71	1,32	10,0	8,49	1,40	9,9	8,34	1,46	9,8	7,92	1,63	9,6						
21	13	8,08	1,33	9,4	7,91	1,42	9,3	7,78	1,48	9,3	7,40	1,67	9,1	6,96	1,90	8,9	6,45	2,17	8,6
	14	8,32	1,33	9,7	8,14	1,42	9,6	8,01	1,48	9,5	7,62	1,67	9,3	7,17	1,90	9,1	6,65	2,16	8,8
	15	8,57	1,33	9,9	8,38	1,42	9,8	8,24	1,48	9,7	7,85	1,67	9,5	7,39	1,89	9,3	6,86	2,16	9,0
	16	8,81	1,33	10,1	8,62	1,42	10,0	8,47	1,48	10,0	8,07	1,67	9,7	7,61	1,89	9,5	7,08	2,15	9,2
	17	9,06	1,33	10,4	8,86	1,42	10,3	8,71	1,48	10,2	8,30	1,67	10,0	7,83	1,89	9,7	7,29	2,14	9,4
	18	9,31	1,33	10,6	9,10	1,42	10,5	8,95	1,48	10,4	8,53	1,67	10,2						
31	13	9,57	1,65	11,2	9,29	1,77	11,1	9,10	1,86	11,0	8,58	2,11	10,7	8,01	2,39	10,4	7,39	2,71	10,1
	14	9,78	1,65	11,4	9,50	1,77	11,3	9,30	1,86	11,2	8,77	2,10	10,9	8,20	2,39	10,6	7,57	2,71	10,3
	15	9,99	1,65	11,6	9,71	1,77	11,5	9,51	1,86	11,4	8,97	2,10	11,1	8,39	2,38	10,8	7,75	2,70	10,5
	16	10,2	1,65	11,9	9,92	1,77	11,7	9,72	1,85	11,6	9,17	2,10	11,3	8,58	2,38	11,0	7,93	2,70	10,6
	17	10,4	1,65	12,1	10,1	1,77	11,9	9,92	1,85	11,8	9,37	2,10	11,5	8,77	2,38	11,2	8,11	2,70	10,8
	18	10,6	1,64	12,2	10,3	1,76	12,1	10,1	1,85	12,0	9,57	2,09	11,7	8,95	2,37	11,3			
41	13	12,8	2,03	14,8	12,5	2,19	14,7	12,2	2,30	14,5	11,5	2,64	14,1	10,7	3,03	13,7	9,87	3,47	13,3
	14	13,2	2,03	15,2	12,8	2,19	15,0	12,6	2,31	14,9	11,9	2,64	14,5	11,1	3,03	14,1	10,2	3,48	13,7
	15	13,5	2,03	15,5	13,2	2,19	15,4	12,9	2,31	15,2	12,2	2,64	14,8	11,4	3,03	14,4	10,5	3,48	14,0
	16	13,9	2,03	15,9	13,5	2,19	15,7	13,3	2,31	15,6	12,5	2,65	15,2	11,7	3,04	14,7	10,8	3,49	14,3
	17	14,3	2,04	16,3	13,9	2,20	16,1	13,6	2,32	15,9	12,9	2,65	15,6	12,0	3,04	15,0	11,1	3,49	14,6
	18	14,7	2,04	16,7	14,3	2,20	16,5	14,0	2,32	16,3	13,2	2,66	15,9	12,3	3,05	15,4	11,4	3,50	14,9
51	13	17,0	2,65	19,7	16,7	2,80	19,5	16,4	2,92	19,3	15,6	3,27	18,9	14,6	3,70	18,3	13,5	4,21	17,7
	14	17,2	2,65	19,9	16,8	2,80	19,6	16,5	2,92	19,4	15,7	3,27	19,0	14,8	3,70	18,5	13,7	4,21	17,9
	15	17,5	2,65	20,2	17,1	2,81	19,9	16,8	2,92	19,7	16,0	3,27	19,3	15,0	3,70	18,7	13,9	4,21	18,1
	16	17,9	2,66	20,6	17,5	2,82	20,3	17,2	2,94	20,1	16,4	3,28	19,7	15,4	3,71	19,1	14,3	4,21	18,5
	17	18,4	2,68	21,1	18,0	2,83	20,8	17,7	2,95	20,7	16,9	3,30	20,2	15,9	3,71	19,6	14,7	4,21	18,9
	18	19,0	2,70	21,7	18,6	2,85	21,5	18,3	2,97	21,3	17,5	3,31	20,8	16,4	3,72	20,1	15,2	4,21	19,4
61	13	20,5	3,55	24,1	20,1	3,73	23,8	19,7	3,87	23,6	18,8	4,26	23,1	17,8	4,73	22,5	16,5	5,27	21,8
	14	21,1	3,56	24,7	20,6	3,74	24,3	20,3	3,88	24,2	19,4	4,27	23,7	18,3	4,74	23,0	17,0	5,28	22,3
	15	21,7	3,58	25,3	21,2	3,76	25,0	20,9	3,89	24,8	19,9	4,29	24,2	18,8	4,75	23,6	17,5	5,29	22,8
	16	22,3	3,59	25,9	21,8	3,77	25,6	21,4	3,91	25,3	20,4	4,30	24,7	19,3	4,76	24,1	18,0	5,30	23,3
	17	22,8	3,61	26,4	22,3	3,79	26,1	22,0	3,92	25,9	21,0	4,31	25,3	19,8	4,77	24,6	18,5	5,31	23,8
	18	23,4	3,62	27,0	22,9	3,80	26,7	22,5	3,94	26,4	21,5	4,33	25,8	20,3	4,79	25,1			
71	13	23,7	4,42	28,1	23,2	4,65	27,9	22,8	4,82	27,6	21,8	5,32	27,1	20,6	5,90	26,5	19,3	6,58	25,9
	14	24,3	4,44	28,7	23,8	4,67	28,5	23,5	4,84	28,3	22,4	5,34	27,7	21,2	5,92	27,1	19,9	6,60	26,5
	15	25,0	4,47	29,5	24,5	4,70	29,2	24,1	4,87	29,0	23,1	5,36	28,5	21,8	5,95	27,8	20,4	6,62	27,0
	16	25,7	4,49	30,2	25,2	4,73	29,9	24,8	4,90	29,7	23,7	5,39	29,1	22,5	5,98	28,5	21,0	6,65	27,7
	17	26,4	4,53	30,9	25,8	4,76	30,6	25,5	4,93	30,4	24,3	5,42	29,7	23,1	6,01	29,1	21,6	6,68	28,3
	18	27,1	4,56	31,7	26,5	4,80	31,3	26,1	4,97	31,1	25,0	5,46	30,5	23,7	6,04	29,7	22,2	6,72	28,9

kWf = Cooling capacity in kW
kWe = Compressor power input in kW
kWt = heating capacity (kW)

To = Temperature of outlet water to evaporator (Cooling) or to condenser (Heating) (°C)
(1) Condenser outlet water temperature, in cooling operation.
(1) Evaporator outlet water temperature, in heating operation.

APPLICATION: UNIT FOR RADIANT PANELS

PERFORMANCES IN COOLING AND IN HEATING

Size	To (°C)	OUTLET WATER TEMPERATURE (1)(°C)																	
		30			33			35			40			45			50		
		kWf	kWe	kWt	kWf	kWe	kWt	kWf	kWe	kWt	kWf	kWe	kWt	kWf	kWe	kWt	kWf	kWe	kWt
81	13	27,4	4,39	31,8	26,7	4,71	31,4	26,2	4,95	31,2	24,7	5,59	30,3	23,0	6,32	29,3	21,1	7,13	28,2
	14	28,2	4,42	32,6	27,5	4,74	32,2	26,9	4,97	31,9	25,4	5,61	31,0	23,7	6,33	30,0	21,7	7,13	28,8
	15	28,9	4,44	33,3	28,2	4,77	33,0	27,7	5,00	32,7	26,2	5,63	31,8	24,4	6,35	30,8	22,3	7,14	29,4
	16	29,7	4,48	34,2	29,0	4,80	33,8	28,5	5,03	33,5	26,9	5,66	32,6	25,1	6,36	31,5	23,0	7,15	30,2
	17	30,5	4,51	35,0	29,8	4,83	34,6	29,2	5,06	34,3	27,7	5,68	33,4	25,8	6,38	32,2	23,6	7,16	30,8
	18	31,3	4,54	35,8	30,6	4,86	35,5	30,0	5,09	35,1	28,4	5,71	34,1	26,5	6,40	32,9	24,3	7,16	31,5
91	13	30,6	5,28	35,9	29,8	5,60	35,4	29,2	5,84	35,0	27,7	6,50	34,2	26,2	7,26	33,5	24,6	8,12	32,7
	14	31,5	5,31	36,8	30,6	5,63	36,2	30,0	5,87	35,9	28,5	6,53	35,0	26,9	7,30	34,2	25,3	8,17	33,5
	15	32,3	5,33	37,6	31,4	5,66	37,1	30,8	5,89	36,7	29,3	6,56	35,9	27,7	7,33	35,0	26,1	8,21	34,3
	16	33,2	5,36	38,6	32,3	5,69	38,0	31,7	5,92	37,6	30,1	6,59	36,7	28,5	7,37	35,9	26,9	8,26	35,2
	17	34,1	5,40	39,5	33,2	5,72	38,9	32,5	5,96	38,5	30,9	6,63	37,5	29,3	7,42	36,7	27,6	8,32	35,9
	18	35,0	5,43	40,4	34,1	5,75	39,9	33,4	5,99	39,4	31,7	6,67	38,4	30,1	7,46	37,6	28,4	8,38	36,8
101	13	38,1	5,86	44,0	37,2	6,22	43,4	36,5	6,48	43,0	34,7	7,20	41,9	32,6	8,02	40,6	30,3	8,95	39,3
	14	39,2	5,89	45,1	38,2	6,25	44,5	37,6	6,51	44,1	35,7	7,23	42,9	33,6	8,05	41,7	31,2	8,98	40,2
	15	40,2	5,93	46,1	39,3	6,28	45,6	38,6	6,54	45,1	36,7	7,26	44,0	34,6	8,08	42,7	32,2	9,01	41,2
	16	41,3	5,96	47,3	40,3	6,31	46,6	39,7	6,57	46,3	37,7	7,29	45,0	35,6	8,11	43,7	33,1	9,04	42,1
	17	42,4	6,00	48,4	41,4	6,35	47,8	40,7	6,61	47,3	38,8	7,32	46,1	36,6	8,14	44,7	34,1	9,07	43,2
	18	43,5	6,03	49,5	42,5	6,39	48,9	41,8	6,64	48,4	39,9	7,36	47,3	37,6	8,18	45,8			
121	13	43,0	7,14	50,1	42,0	7,50	49,5	41,3	7,77	49,1	39,1	8,53	47,6	36,5	9,41	45,9	33,6	10,4	44,0
	14	44,3	7,18	51,5	43,2	7,54	50,7	42,5	7,81	50,3	40,2	8,56	48,8	37,6	9,43	47,0	34,5	10,4	44,9
	15	45,5	7,22	52,7	44,5	7,58	52,1	43,7	7,84	51,5	41,4	8,59	50,0	38,7	9,45	48,2	35,5	10,4	45,9
	16	46,8	7,26	54,1	45,8	7,61	53,4	44,9	7,88	52,8	42,6	8,62	51,2	39,7	9,48	49,2	36,4	10,5	46,9
	17	48,2	7,30	55,5	47,0	7,65	54,7	46,2	7,91	54,1	43,7	8,65	52,4	40,8	9,50	50,3	37,4	10,5	47,9
	18	49,5	7,34	56,8	48,4	7,69	56,1	47,5	7,95	55,5	45,0	8,68	53,7	41,9	9,52	51,4			

kWf = Cooling capacity in kW

kWe = Compressor power input in kW

kWt = heating capacity (kW)

To = Temperature of outlet water to evaporator (Cooling) or to condenser (Heating) (°C)

(1) Condenser outlet water temperature, in cooling operation.

(1) Evaporator outlet water temperature, in heating operation.

ACCESSORIES

(IVMS -)two way modulating motorised valve

If the temperature of the inlet water at the heat exchanger on the source side is less than 15°C it is advisable to reduce the flow rate of the water to allow proper operation of the unit.
 The modulating valve, installed at the inlet of the heat exchanger in the source side, modulates the water flow rate via a 0-10V signal generated by the electronic control of the unit.
 With the unit shut down the valve is completely closed, allowing water savings.
 The modulating valve is the simplest solution as compared to traditional pressure switch valve which must always be used in conjunction with a motorized bypass valve.

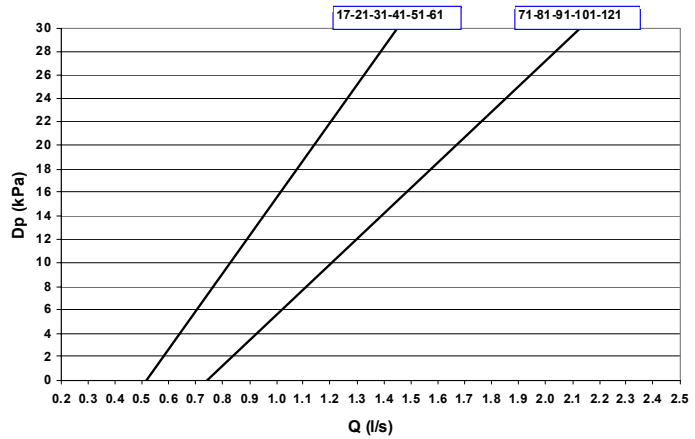

Q = WATER FLOW
DP = PRESSURE DROP

separately supplied accessories

(IVW -)ON/OFF two ways motorized interception valve

motorised two-way valve at the exchanger outlet on the water side. The operation of the valve is linked to the operation of the refrigerant circuit, that is, when the compressor is off the valve is closed, and when the compressor is on the valve is open.

separately supplied accessories

(-)Unit without hydronic group utility side

The unit can be requested without circulating pump, expansion vessel, safety valve water side and filling assembly.

Configuration Detail

(HYGS -)unit with hydronic group source side

Configuration not available for sizes 101 and 121

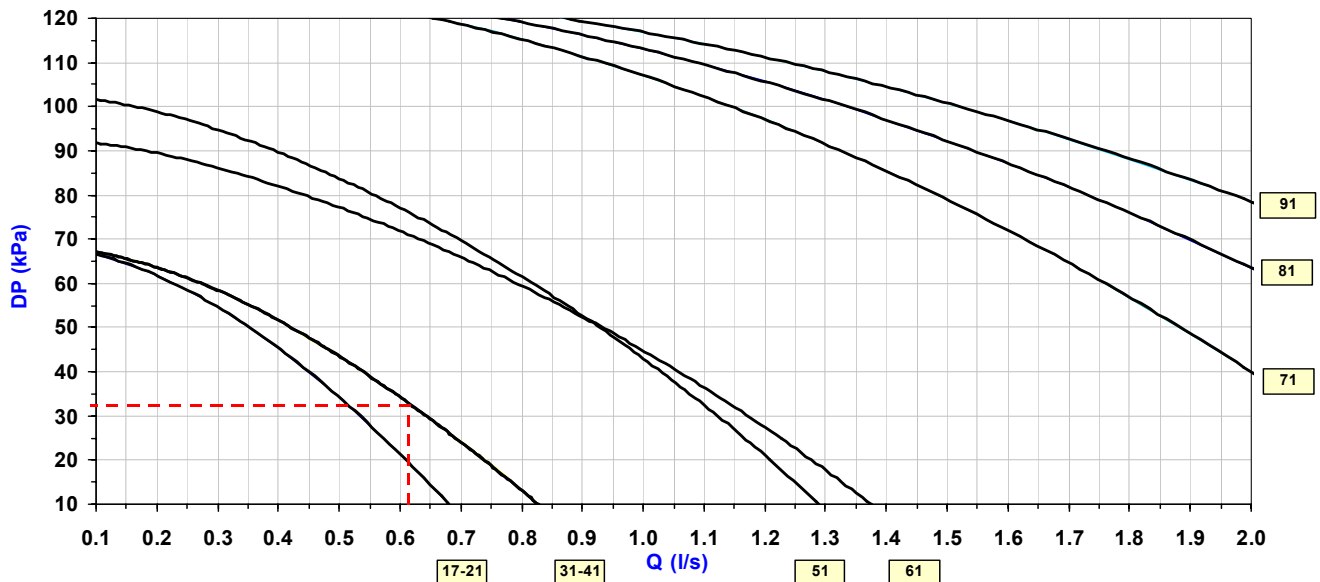

Q = WATER FLOW
DP = AVAILABLE HEAD

Configuration Detail

BT06G008GB-02

HYDRONIC
17 - 121

(OHI -)Operation with reversal on water circuit

version that allows water-water heat pump operation with reversing on the water circuit. Suitable for the production of domestic and industrial hot water. The external exchangers are lined with closed cell heat insulation material.

Configuration Detail

(PM -)phase monitor

The phase monitor allows to check the right presence of electric supply phases for 400/3/50 units.

separately supplied accessories

(SFSTR -)Disposal for inrush current reduction

Starting up a motor directly can overload the electricity network, with start-up currents up to 8 times the nominal current. Thanks to the breakaway current reduction device, start-up takes place gradually, with the start-up current being limited during this period of time. The start-up current can therefore be reduced to 3.5 - 4 times the nominal current, meaning that the power systems and protection devices can be sized with lower parameters.

Configuration Detail

(3WV -)three-way valve

The unit is provided with a 3-way on/off valve to divert the flow of water to a hot water storage tank. Activation of the 3-way valve takes place by means of closure of a dry contact on the electrical board of the unit. As soon as this function is enabled, the set point of the unit is placed at the value established by the appropriate parameter in the electronic control.

The three way valve is supplied only in operation with reversibility on water circuit and for only operation in heating

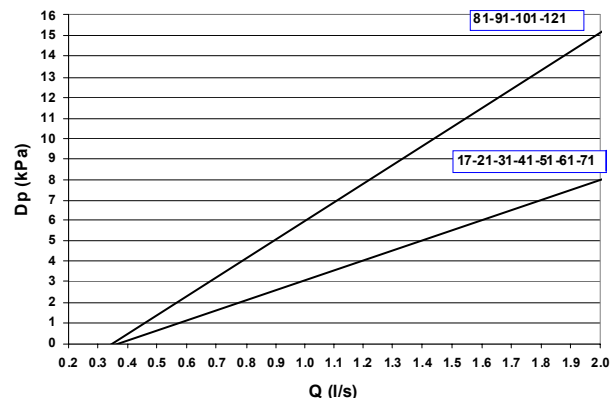

Q = WATER FLOW
DP = PRESSURE DROP

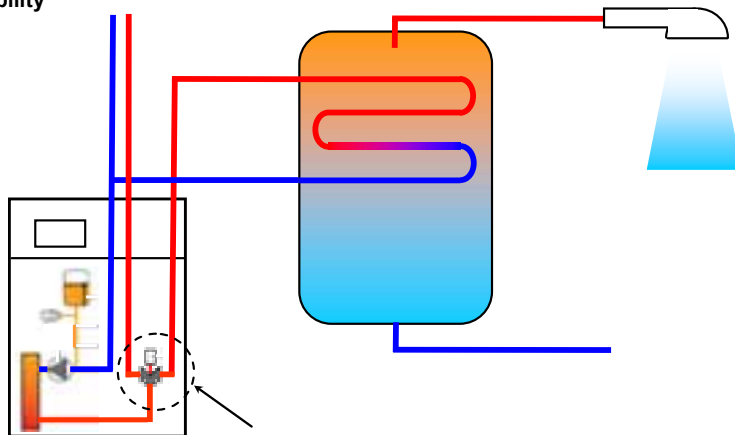

Configuration Detail

(PBL1 -)Service keypad (cable from 1,5 metres)

The service keyboard is necessary for the unit programming and setting. These operations must be done by qualified personnel without compromising the operation of the whole unit. The service keyboard is supplied with a connection cable of 1,5 m length



separately supplied accessories

BT06G008GB-02

(CMMB -)serial communication module to supervisor (MODBUS)

The serial communication module to supervisor (MODBUS) is connected with the principal module through a comb connection (see lay-out on electrical panel). In this way the remote assistance and supervision are available through standard MODBUS protocol. It is possible to connect to a single supervisor system up to 127 units. The connection to PC must be obtained through a converter RS485/232; the serial port RS232 admits as maximum a 10 m length. The serial communication module to supervisor (MODBUS) is necessary when the unit is connected to ELFOCONTROL.

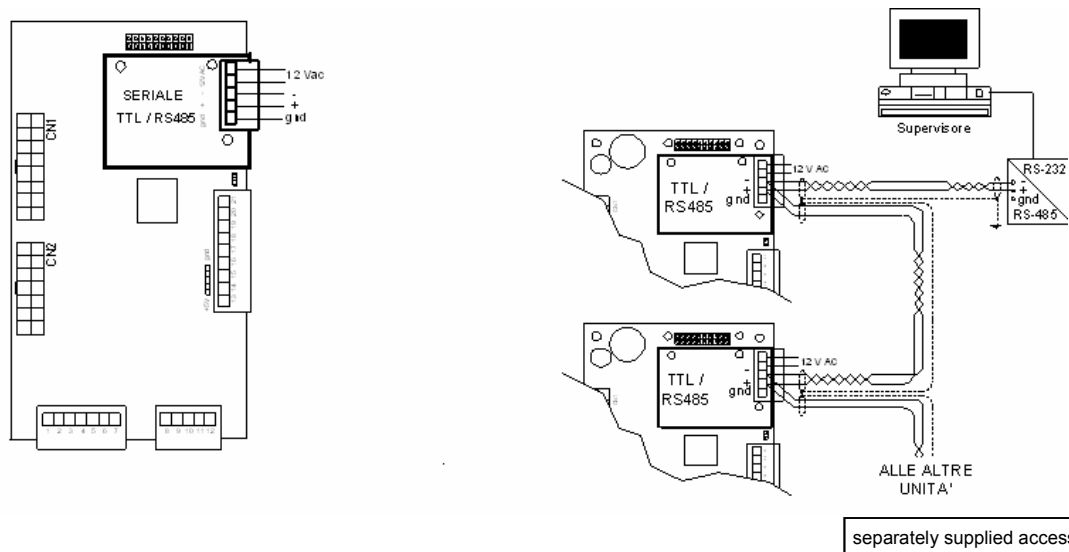

separately supplied accessories

(SCP3 -)Set point compensation with according to outdoor enthalpy

It allows to modulate the unit set point according to the external enthalpy. By energy efficiency optimization, it optimizes also the defrosting times during winter operation. The humidity probe is electronically connected to the main control module present in the unit.



separately supplied accessories

(SPC -)set point compensation with outside temperature probe

Set point compensation by air temperature probe varies the value of the set point according to the outside air temperature, allowing energy savings. The probe is connected to the principal unit control module and the connection cable length is of 20 metres.



separately supplied accessories

(KDT3 -)Double temperature control kit, set point compensation with 4-20mA, 3 ways valve.

It is an expansion card that is connected to the unit standard electronic system. It allows:

(1)double temperature control kit

High and low temperature control for mixed systems radiant panels - fan coil/radiator thanks to the systems mixing valve, pump and outlet probe control. Thanks to parameters set on the electronics (set by the service keyboard) it is possible to set the climatic curve, that allows the outlet temperature decrease to the radiant panels according to the ambient air temperature.

Humidity control and all additional regulations/controls are excluded from the Clivet supply.

- (1) UNIT ELECTRIC PANEL
- (2) EXPANSION VESSEL
- (3) SAFETY VALVE
- (4) PUMP
- (5) 3 WAYS-VALVE (OPTIONAL)
- (6) RADIANT PANELS
- (7) TERMINAL UNITS

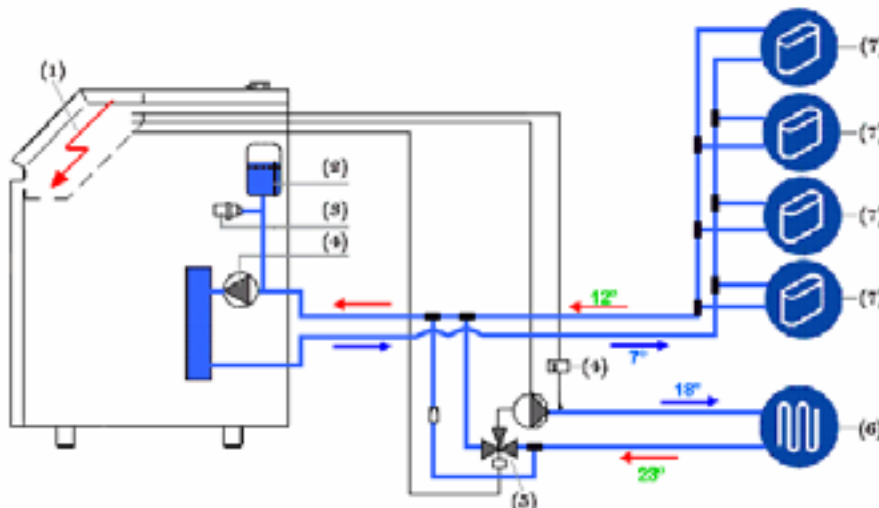

(2)set point compensation with 4-20 mA signal

Dynamic set point variation on the basis of a WATER RESET signal (4-20 mA) from an external device.

(3)3-way valve

On/off 3-way valve control for water flow deviation to an heating storage tank of sanitary water. The 3-way valve is activated by closing the free contacts present in the unit electrical panel. When this function is enabled, the unit set point is set on the value fixed by the parameter in the electronic control.

- (1) UNIT ELECTRIC PANEL
- (2) EXPANSION VESSEL
- (3) SAFETY VALVE
- (4) PUMP
- (5) 3 WAYS-VALVE (OPTIONAL)
- (6) TERMINAL UNITS
- (7) RADIANT PANELS
- (8) WATERWORKS WATER INLET
- (9) SANITARY WATER

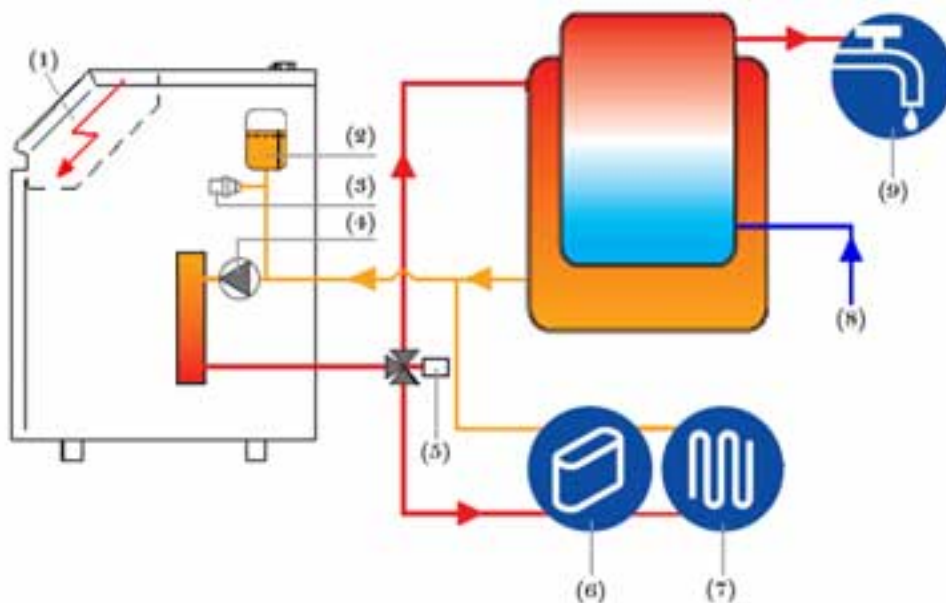

separately supplied accessories

(AMR -)rubber antivibration mounts

The rubber antivibration mounts reduce the vibrations of compressor during its operation and they are installed at the base toe.

separately supplied accessories

DIMENSIONAL DRAWING

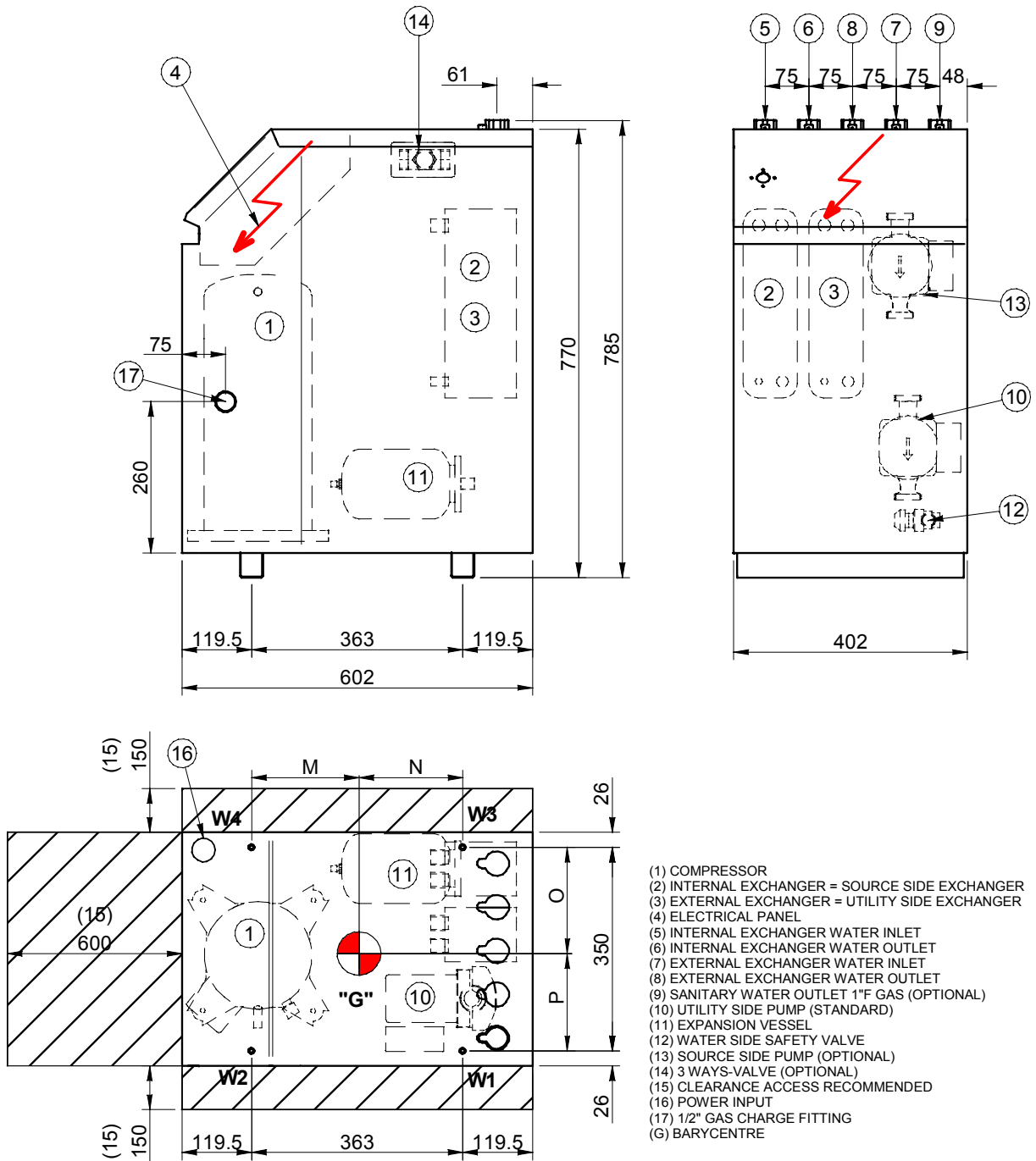

SIZE		17	21	31	41	51
M	mm	180	176	181	193	175
N	mm	186	187	186	170	188
O	mm	170	170	168	168	170
P	mm	180	180	182	182	180
Length	mm	402	402	402	402	402
Depth	mm	602	602	602	602	602
Height	mm	785	785	785	785	785
W1	kg	18	18	20	20	22
W2	kg	20	21	21	22	27
W3	kg	20	19	21	22	24
W4	kg	22	23	23	24	29
Operating weight	kg	80	81	85	88	102
Shipping weight	kg	78	79	83	85	99

BT06G008GB-02

DIMENSIONAL DRAWING

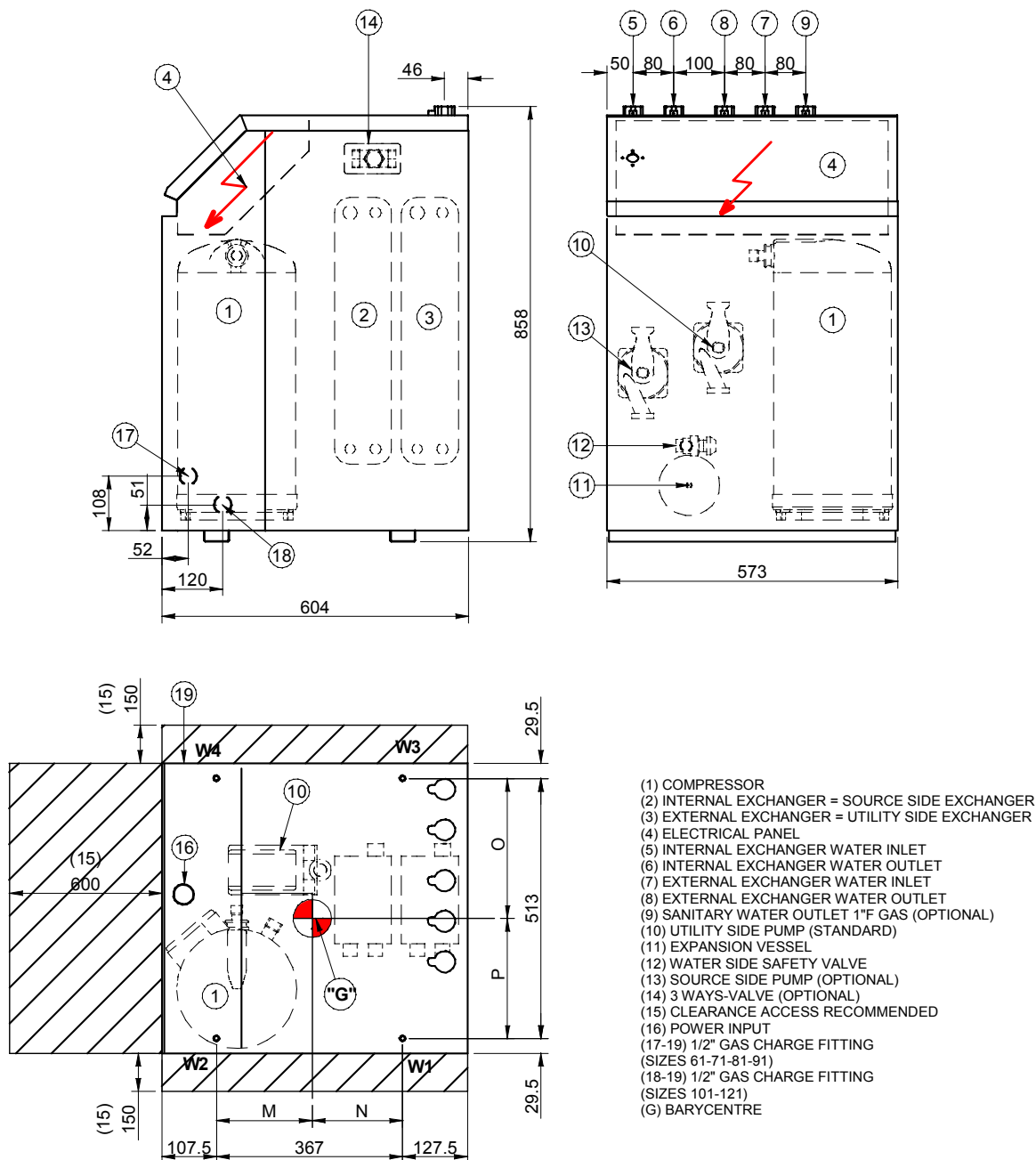

- (1) COMPRESSOR
- (2) INTERNAL EXCHANGER = SOURCE SIDE EXCHANGER
- (3) EXTERNAL EXCHANGER = UTILITY SIDE EXCHANGER
- (4) ELECTRICAL PANEL
- (5) INTERNAL EXCHANGER WATER INLET
- (6) INTERNAL EXCHANGER WATER OUTLET
- (7) EXTERNAL EXCHANGER WATER INLET
- (8) EXTERNAL EXCHANGER WATER OUTLET
- (9) SANITARY WATER OUTLET 1" F GAS (OPTIONAL)
- (10) UTILITY SIDE PUMP (STANDARD)
- (11) EXPANSION VESSEL
- (12) WATER SIDE SAFETY VALVE
- (13) SOURCE SIDE PUMP (OPTIONAL)
- (14) 3 WAYS-VALVE (OPTIONAL)
- (15) CLEARANCE ACCESS RECOMMENDED
- (16) POWER INPUT
- (17-19) 1/2" GAS CHARGE FITTING (SIZES 61-71-81-91)
- (18-19) 1/2" GAS CHARGE FITTING (SIZES 101-121)
- (G) BARYCENTRE

SIZE		61	71	81	91	101	121
M	mm	152	165	173	174	175	182
N	mm	215	202	197	193	192	185
O	mm	285	300	330	333	336	331
P	mm	228	213	186	180	177	182
Length	mm	573	573	573	573	573	573
Depth	mm	604	604	604	604	604	604
Height	mm	858	858	858	858	858	858
W1	kg	19	29	41	46	48	53
W2	kg	45	47	55	59	59	56
W3	kg	15	20	21	23	23	27
W4	kg	35	32	26	29	29	28
Operating weight	kg	114	128	143	157	159	164
Shipping weight	kg	111	125	140	153	155	160

CLIVET SPA
Feltre (BL) ITALY
Tel. + 39 0439 3131
Fax + 39 0439 313300
info@clivet.it

CLIVET ESPAÑA S.A.
(Madrid) SPAIN
Tel. + 34 91 6658280
Fax + 34 91 6657806
info@clivet.es

CLIVET UK LTD
Fareham (Hampshire) U.K.
Tel. + 44 (0) 1489 572238
Fax + 44 (0) 1489 573033
info@clivet-uk.co.uk

CLIVET NEDERLAND B.V.
Amersfoort - Netherlands
Tel. + 31 (0) 33 7503420
Fax + 31 (0) 33 7503424
info@clivet.nl

CLIVET TFA (PVT) LTD
Bangalore - INDIA
Tel. + 91 80 25351617
Fax + 91 80 25351392
sales@clivetfa.com

The data contained in this bulletin is not binding and may be changed by the manufacturer without prior notice. All reproduction, even partial, is prohibited.
© Copyright - CLIVET S.p.A. - Feltre (BL) - Italy