

/ Marley Aquatower® Cooling Tower /

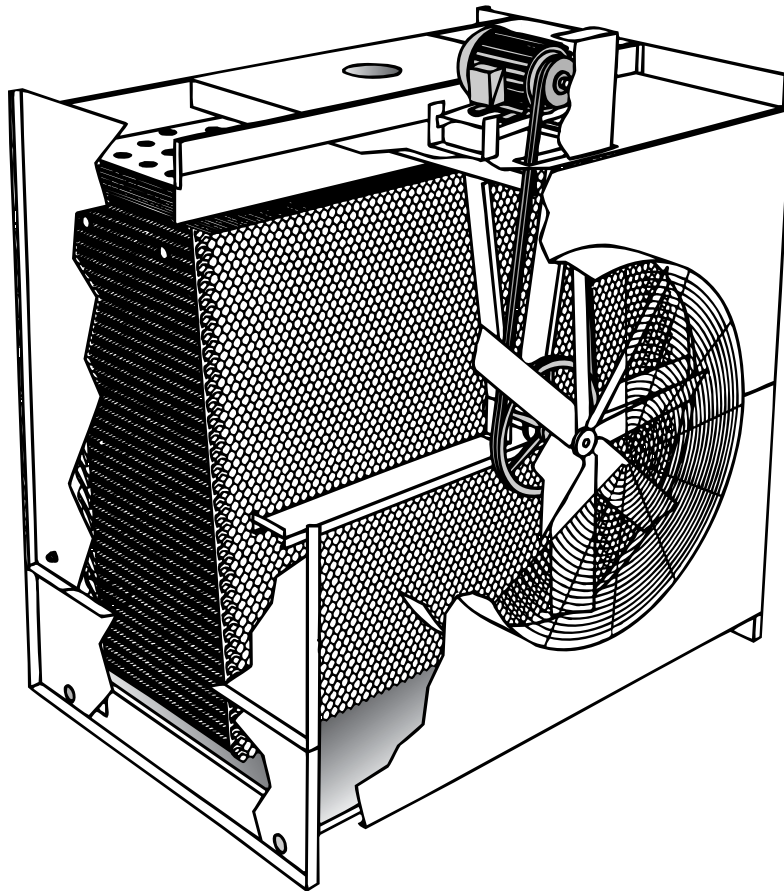

/ The Aquatower Advantage /



- **Proven Performance.** CTI Certified. Plus SPX stands by its responsibility for reliable thermal performance. We designed it. We rate it. *We guarantee it!*
- **Induced-Draft Design.** Save on fan power and avoid the water leaks typical in forced-draft—pressurized—towers. The fan will operate in a warm atmosphere even in winter, so you'll never have to work on frozen mechanical equipment.
- **Crossflow Design.** Save on pump power because you only pay to move the water to the top of the tower. Gravity does the rest. The mechanical equipment and water distribution system are out where you can easily maintain them.
- **All-Season Reliability.** Aquatowers perform as specified in the heat of summer. They respond well to energy management techniques in the spring and fall and with appropriate fan controls, they can operate virtually ice-free in the dead of winter. Plus they offer simple maintenance all year long.
- **Proven Corrosion Protection.** Thousands of users over more than 40 years confirm the value of heavy galvanizing. And Marley's G-235 is the most effective galvanizing used in the industry.
- **PVC Film Fill with Integral Drift Eliminators and Louvers.** If you've ever had to replace deteriorated eliminators or louvers, you'll appreciate this advantage. Now those components are molded right in the PVC fill sheets. Integral honeycomb louvers keep the circulating water inside your tower—and off your roof!
- **Select Your Aquatower From This Bulletin.** The table on page 6 should be adequate for almost all your requirements. If available space is a problem, or if you run into some unusual operating requirements, we'll be glad to help. Also, the Marley *UPDATE* web-based selection software—available at www.spxcooling.com—provides Aquatower model recommendations based on your specific design requirements
- **Simple, Flexible Installation.** Just mount the motor, belts and belt guard, install the outlet connection that suits your needs—both side suction and bottom outlet are provided,

/ The Marley Difference /



Today's Aquatower may be the most space/energy-efficient cooling tower available. Your needs have dictated constant technological improvement. Thousands of Aquatower users enjoy the benefits of eight major redesigns and dozens of minor improvements in the past 40 years. For example, PVC film-fill enables the Aquatower to reject more heat per unit size. We also put the air inlet louvers and drift eliminators right on the fill sheets. This new arrangement saves you fan horsepower by improving airflow through the tower.

The Aquatower is a maintenance delight! You'll appreciate the way the Aquatower simplifies maintenance. No hidden spray systems, tiny nozzles, or enclosed basins here! You can easily replace and align V-belts from outside the tower. You won't have the chore and expense that goes with high-horsepower, blower fan towers.

All primary components of the Aquatower are open to view. You can easily remove any debris from the upper basin or nozzles while the tower is in operation.

Heavy mill galvanizing on all steel components prevents base metal corrosion. You won't have to worry about paint chips clogging your strainers and nozzles, because there is no paint to flake off. Heavy galvanizing also protects much better than paint.

Above all, the Aquatower is readily available. You won't have to wait around—or accept second best—when you need a cooling tower. We maintain an impressive stock of completed towers at our own plants. A growing number of local distributors can draw from that stock.

Contact your local distributor or Marley representative. They'll be glad to help you choose the proper model for your needs. They can also help you with your layout and piping.

You'll enjoy single source responsibility and reliability because we design and manufacture virtually all major cooling tower components.

All Marley components are designed and selected to be a part of an integrated system. For example, the spray pattern from nozzles and the pressure drop through drift eliminators both affect a fill's heat transfer capacity. So, we include that impact in our thermal analysis.

Drift eliminators must be effective at the air velocities where fill is most efficient. So, we've carefully designed both components to work together efficiently.

How many other cooling tower companies can offer you this assurance? They may use Brand "A" nozzles with Brand "B" fill and Brand "C" drift eliminators. When they all come together, the whole may be less than the sum of the parts.

Our total system approach assures that all the parts work together to provide you the greatest total performance.

And because we design specifically for cooling towers, all our components will provide many years of service with minimal maintenance.

Every Aquatower cooling tower carries a full one-year warranty. The Aquatower you buy from us will work on your job or we'll make it right. Your warranty includes thermal performance and every component of the tower. The SPX Cooling Technologies warranty is your assurance of performance—for a full year.

The Aquatower has inspired many imitators. Only SPX Cooling Technologies can offer you the original.

/ Schematic /

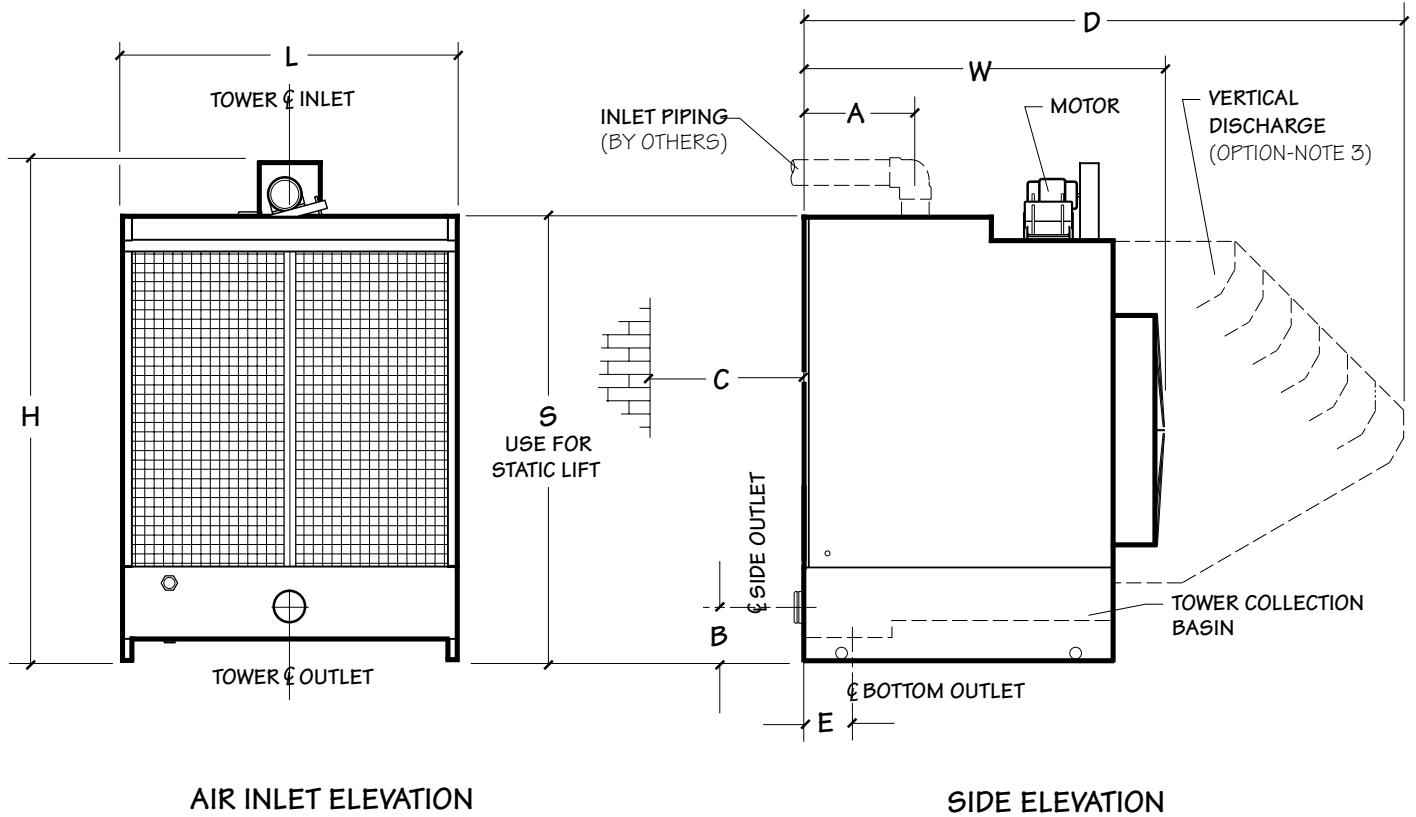

AIR INLET ELEVATION

SIDE ELEVATION

Tower Model	Nominal Tons 1	DIMENSIONS									Motor hp	Piping Connections			
		L	W	H	A	B	C 2	D	E	S		Inlet	Outlet 6		
490A	8	2'-11 1/2"	4'-2 7/8"	5'-3 3/8"	1'-3 13/16"	6 7/8"	2'-0"	note 3	note 6	4'-3 7/8"	1/3	2"	2" F		
490B	10	902mm	1292mm	1610mm	402mm	175mm	610mm			1318mm	1				
492A	22	3'-11 1/2"	5'-0 3/4"	7'-4 1/2"	1'-5"	9 1/2"	4'-0"			8"	6'-5"	1	4"	4" M	
492B	28	1206mm	1543mm	2248mm	432mm	241mm	1219mm	203mm	1956mm	2					
493A	36	5'-11 1/2"	5'-1"	7'-4 1/2"	1'-5"	9 1/2"	5'-0"	8"	203mm	6'-5"	2	6"	6" MC		
493B	42	1816mm	1549mm	2248mm	432mm	241mm	1524mm			1956mm	3				
494A	51	5'-11 1/2"	6'-5 5/8"	9'-0"	1'-11 15/16"	11 1/2"	6'-0"	10'-8"	9 1/4"	7'-10 5/8"	2	6"	6" MC		
494B	57			2743mm	608mm	292mm	1829mm			3251mm	235mm			2403mm	3
494C	68			2743mm	608mm	292mm	1829mm			3251mm	235mm			2403mm	5
495A	80	7'-11 1/2"	6'-5 3/4"	9'-0"	1'-11 15/16"	11 1/2"	7'-0"	10'-8"	9 1/4"	7'-10 5/8"	5	6"	6" MC		
495B	91	2426mm	1975mm	2743mm	608mm	292mm	2134mm			3251mm	235mm			2403mm	7 1/2
496A	111	9'-11 1/2"	6'-6 1/8"	9'-8 1/4"	1'-11 3/16"	11 1/2"	9'-0"	10'-11 11/16"	9 1/4"	8'-6 3/4"	5	6"	6" MC		
496B	126	3035mm	1984mm	2953mm	589mm	292mm	2743mm			3345mm	235mm			2610mm	7 1/2

- Nominal tons are based upon 95°F HW, 85°F CW, 78°F WB, and 3 GPM/Ton.
- Minimum clearance for adequate air supply. Consult your Marley sales representative or your local distributor if this clearance is impractical for your job.
- Vertical discharge hood is for applications in restrictive enclosures or other locations where horizontal discharge is not desirable. CTI Certification does not apply when this option is selected. Available only on models 494A and larger.
- Motors less than 1 hp are 115/230 volt, single-phase TENV. 1 hp through 7.5 hp motors are 230/460 volt, 3-phase TEFC. See page 7 for optional motor sizes on Models 490B through 492A.
- Motor, belt and belt guard ship uninstalled. Installation by others.
- Outlet sizes shown are side outlets. All models except 490A and 490B have connections for both side and bottom outlet. Install the desired connection and seal the unused opening with the coverplate provided. Pump suction should use side outlet. See page 11 for size and flow capacities of bottom outlets.
- Overflow is a 2" F connector located in side of collection basin.
- Drain is a 2" F connection located in collection basin floor.
- Makeup valve connection is 3/4" M located in tower side.

/ Support /

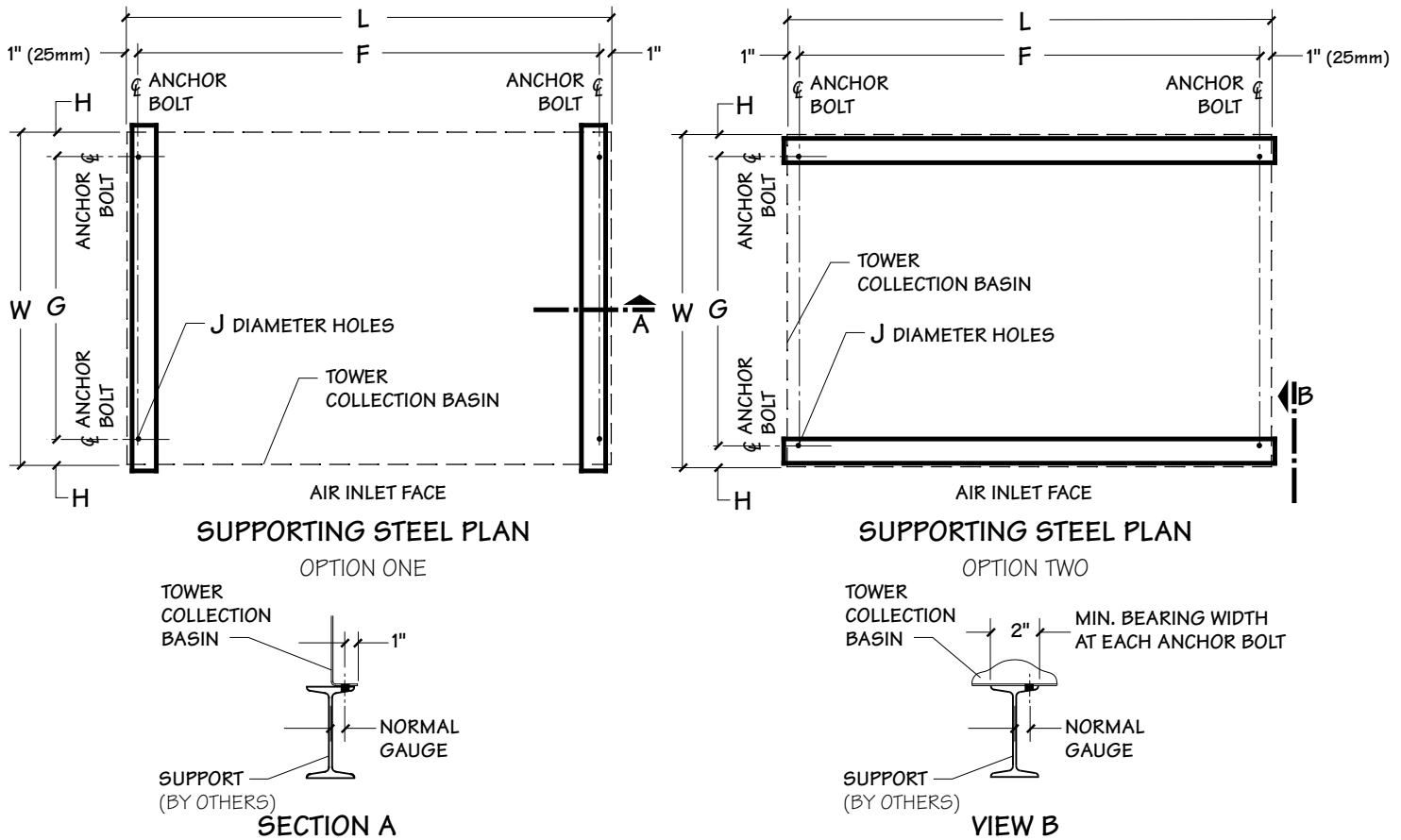

Tower Model	DIMENSIONS						Shipping Weight lb	Maximum Operating Weight lb	Maximum Operating Load at Anchor lb	Wind Loads lb		
	L	W	F	G	H	J				Max. Vertical Reaction at Anchor	Max. Horizontal Reaction at Anchor	
490A-490B	2'-11 1/2"	3'-4 1/8"	2'-9 1/2"	3'-0"	2 1/16"	5/8"	437	756	185	180	115	
	902mm	1019mm	851mm	915mm	52mm							
492A-492B	3'-11 1/2"	4'-1 5/8"	3'-9 1/2"	3'-6"	3 13/16"			742	1396	349	355	210
	1206mm	1260mm	1156mm	1067mm	97mm							
493A-493B	5'-11 1/2"	4'-1 5/8"	5'-9 1/2"	3'-6"	3 13/16"			982	1995	499	525	285
	1816mm	1260mm	1765mm	1067mm	97mm							
494A-494C	5'-11 1/2"	5'-6 1/8"	5'-9 1/2"	5'-0"	3 1/16"		1398	2948	737	555	355	
	1816mm	1680mm	1765mm	1524mm	78mm							
495A-495B	7'-11 1/2"	5'-6 1/8"	7'-9 1/2"	5'-0"	3 1/16"		1758	3853	963	745	470	
	2426mm	1680mm	2375mm	1524mm	78mm							
496A-496B	9'-11 1/2"	5'-6 1/8"	9'-9 1/2"	5'-0"	3 1/16"		2096	4751	1188	1095	640	
	3035mm	1680mm	2985mm	1524mm	78mm							
Models with Vertical Discharge Hood Option												
494A-494C	5'-11 1/2"	5'-6 1/8"	5'-9 1/2"	5'-0"	3 1/16"	5/8"	1798	3348	837	700	515	
495A-495B	7'-11 1/2"	5'-6 1/8"	7'-9 1/2"	5'-0"	3 1/16"			2133	4233	1058	745	515
496A-496B	9'-11 1/2"	5'-6 1/8"	9'-9 1/2"	5'-0"	3 1/16"			2596	5251	1313	1095	640

- Use this bulletin for preliminary layouts only. Obtain current drawings from your Marley sales representative or your local distributor.
- Purchaser to provide tower supports complete with holes and bolts for anchorage. All supports must be framed flush and level at top. Maximum deflection to be 1/360th of span, not to exceed 1/2" (13mm).
- Maximum weight occurs with basin full to overflow level at shutdown. Actual operating weight varies with GPM and piping scheme.
- Wind loads are based on 30 psf and are additive to operating loads. Reactions due to wind loads exceed those resulting from seismic loads based on the 1997 UBC code, Zone 4 and an Importance Factor of 1.00 per Section 1634—Towers Not on a Building.

/ Model Selection /



Tower Model	Motor bhp	temp	GPM Cooling capability at indicated Hot Water, Cold Water and Wet-Bulb temperatures											
		HW ° F	95	96	100	102	95	97	100	102	95	97	100	102
		CW ° F	85	86	85	87	85	87	85	87	85	87	85	87
		WB ° F	80	80	80	80	78	78	78	78	76	76	76	76
490A	1/8		19	22	15	19	24	30	19	23	28	34	21	26
490B	1		24	28	19	24	30	38	23	28	36	44	27	32
492A	1		53	61	42	53	66	82	51	62	78	93	59	70
492B	2		68	78	53	68	84	104	64	79	99	119	75	89
493A	2		87	100	69	87	108	134	83	101	128	153	97	115
493B	3		101	117	79	101	126	157	96	118	149	179	113	134
494A	2		125	143	101	126	153	187	120	145	178	211	138	162
494B	3		140	160	112	141	171	209	134	162	199	236	154	181
494C	5		167	190	**	168	204	249	**	193	238	281	184	216
495A	4		196	224	157	197	240	293	188	227	280	332	217	254
495B	6		223	255	178	224	273	334	214	258	319	378	246	289
496A	5		273	311	219	274	333	406	262	315	388	459	301	353
496B	7 1/2		310	353	248	311	378	460	297	357	440	520	341	400

Tower Model	Motor bhp	temp	GPM Cooling capability at indicated Hot Water, Cold Water and Wet-Bulb temperatures												
		HW ° F	95	100	90	95	90	95	90	95	90	95	90	95	
		CW ° F	85	85	80	80	80	80	80	80	80	80	80	80	80
		WB ° F	75	75	72	72	70	70	68	68	66	66	64	64	
490A	1/8		31	23	23	18	27	20	31	23	34	25	38	27	
490B	1		39	29	29	22	34	25	39	28	44	31	48	34	
492A	1		84	63	64	49	74	56	84	63	93	69	102	75	
492B	2		107	80	81	62	95	71	107	80	119	88	131	96	
493A	2		137	103	105	80	122	91	138	102	153	113	168	123	
493B	3		160	120	122	92	142	106	161	119	180	132	197	144	
494A	2		190	147	148	115	170	131	191	146	211	159	229	172	
494B	3		213	164	166	129	190	146	214	163	235	178	256	192	
494C	5		254	196	198	**	227	174	255	194	280	212	304	229	
495A	4		299	230	232	181	268	205	301	228	332	250	361	270	
495B	6		340	262	264	205	304	233	342	259	377	284	410	307	
496A	5		414	319	323	251	371	285	416	317	458	346	497	374	
496B	7 1/2		470	362	366	285	421	324	471	360	519	393	563	425	

** Tower capacity less than minimum water flow limit.

• Thermal performance of the Aquatower has been certified by CTI (Cooling Tower Institute) in accordance with CTI Standard STD-201(02), and has been assigned CTI certification validation number 01-14-05.

• CTI Certification under STD-201(02) applies ONLY to selections with entering water temperature of 125°F or less, temperature ranges of 4°F or more, temperature approaches of 5°F or more, and wet bulb temperatures between 60°F and 85°F.

/ Options /

Option	Description
200V Motor	Available for 1 hp thru 7.5 hp. Models 490B thru 496B
Special Motors	Two-speed, one-wind, 460 volt, 60 cycle, 3 phase, TEFC motors are available for Models 494C thru 496B
Field Assembly	Where unique space restrictions or rigging conditions demand, Aquatowers can be shipped ready for field assembly by others. Complete step-by-step assembly instructions are provided.



Vertical Discharge Hood	<p>This option is available on Models 494A and larger. It provides vertical discharge of the air leaving the tower. Hoods are galvanized steel. They ship separately for installation by others. A large access door provides entry to the fan and mechanical equipment.</p> <p>For use in restrictive enclosures or other site situations where horizontal discharge is not desirable. CTI Certification does not apply when this option is selected.</p>
-------------------------	--

Option	Description
Component Basin Heaters	Standard heater components consist of 3 or 5 kW, 3 phase, 460 volt, shielded immersion heater; solid state circuitry for cut-off at low water level or high temperature; a control probe to monitor basin water temperature and water level; and a magnetic contactor all housed in a weatherproof enclosure. Components are shipped separately for installation and wiring by others. Designed to prevent sump freezing during shutdown periods in winter operation. Unnecessary if you use an indoor tank. Special heater characteristics result in extended lead times.

Pre-assembled Basin Heaters	Tank-type submersible heaters are available for all models. No tower modifications are necessary and heater includes a 6-foot electrical cord with grounded 3-prong plug for connection to a standard 120V source. One or more 1.5 kW elements provide protection at most ambient conditions. The built-in thermostat maintains 40°F water while the built-in safety switch shuts off power if the heater element is not submerged.
-----------------------------	---

Stainless Steel Construction	All Aquatower models are available with stainless steel structure. Or you can choose a galvanized tower with a stainless steel cold water collection basin. Your Marley sales representative can help you choose the amount of corrosion resistance necessary for your installation.
------------------------------	--

Control System	Factory-installed control center in NEMA 3R enclosure mounted on tower casing. Complete with thermostat controller for single or two-speed motors to maintain chosen cold water temperature.
----------------	--

/ Construction And Components /

■ Water Distribution System

Warm water flows through external piping (not included with the tower) into a splash box chamber at the top of the Aquatower. A splash box prevents the incoming water from spilling out of the basin and helps provide uniform water distribution. Water then flows by gravity from the basin through nozzles to the fill.



Eliminator air-seal removed showing distribution area above fill

Hot water distribution basin covers are provided as standard equipment to keep the distribution basin free from airborne debris and to reduce the likelihood of biological growth.

All Aquatowers use Marley “Spiral Target” nozzles. These inert polypropylene nozzles are evenly spaced throughout the distribution basin to assure uniform water distribution over all portions of the fill. Their large openings resist clogging. Nozzles are easy to remove and replace if you ever want to change the design water flow rate.



Spiral-target distribution nozzle

■ Fill/Louvers/Drift Eliminators

Fill sheets include integral louvers and drift eliminators, designed to minimize resistance to airflow. This patented arrangement prevents water from escaping the fill sheets, assuring proper heat transfer throughout wide variations in airflow. Users find this fill operates ice-free even in extremely cold weather.

The thermoformed 15 mil (.015”) thick PVC fill sheets withstand hot water temperatures as high as 125°F. Fill sheets are immune to biological and corrosive decay and their flame spread rating is less than 25 per ASTM E-84. Galvanized structural tubes support and stabilize the fill. They also hold the bottom of the fill sheets above the cold water basin floor to simplify basin cleaning. Removable 1” x 1” mesh galvanized air inlet screens keep larger airborne trash out of the collection basin and fill area.



MX Fill

■ Cold Water Collection Basin

The Aquatower’s collection basin reduces operating weight, simplifies basin cleaning, and assures proper outflow. Water flows from the elevated area under the fill into the basin’s rear depressed section, where side suction piping connects. A bottom outlet is also available for gravity flow applications.

Standard equipment on each tower basin includes: a screened suction connection; a threaded overflow connection; a threaded and plugged drain connection; and a float-operated make-up valve. Models 492A through 496B also include a bottom outlet conforming to 125# flange specification. A blank cover plate is provided to seal the outlet connection not used.

/ Construction And Components /

■ Mechanical Equipment

Belt-driven propeller fans insure design airflow at minimum horsepower. Fans are supported by an oil-lubricated tapered roller bearing assembly with remote oil reservoir.

For ease of maintenance all drive components are accessible from outside the tower.

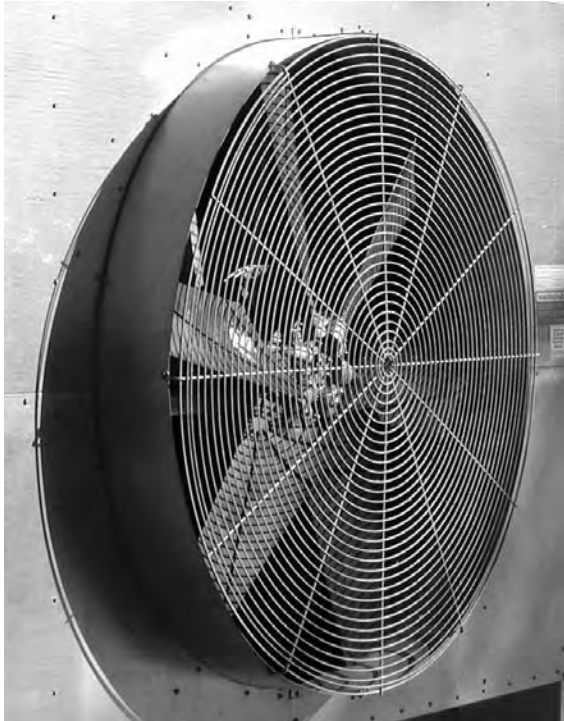

Fan and fan guard. Guard is easily removed for access to fan and drive belts

Fan drive motors are TEFC (may be TENV on model 490A) designed specifically for cooling tower use. Horsepowers and electrical characteristics appear in the table on page 4. Other types of motors are available. Typical options appear under Optional Accessories on page 7.

⚠ Caution

The cooling tower must be located at such distance and direction to avoid the possibility of contaminated tower discharge air being drawn into building fresh air intake ducts. The purchaser should obtain the services of a Licensed Professional Engineer or Registered Architect to certify that the location of the tower is in compliance with applicable air pollution, fire, and clean air codes.

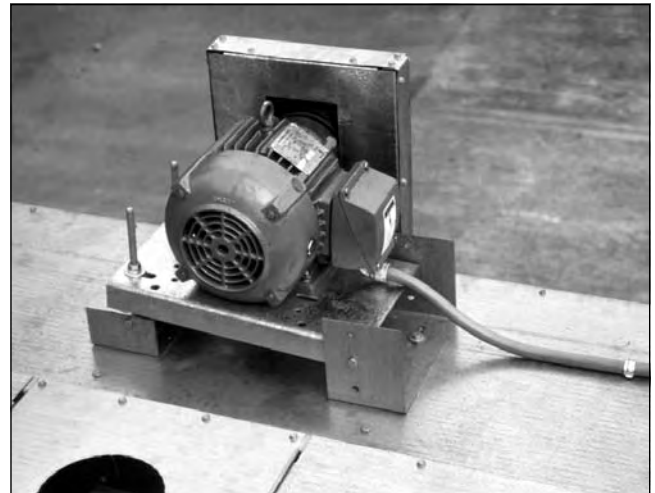

Fan drive motor showing adjustable base and belt guard

■ Hoisting and Handling

Hoisting instructions on each tower explains how to use a spreader-bar and slings beneath the cold water basin floor to hoist the Aquatower. The tower's design also allows easy handling with a forklift.

■ Safety

Standard Aquatower safety features include fan guards and belt guards. Fan guards consist of welded heavy gauge steel wire hoops and spokes, hot dip galvanized after fabrication. The galvanized steel belt guard encloses both belts and pulleys. Guards are easily removed for servicing.

■ Construction and Finish

Aquatowers offer the corrosion protection of G-235 galvanized—providing a zinc thickness of 2.35 oz/ft² per ASTM A-653—providing long term protection for the steel. Assembly hardware is also galvanized.

/ Freeze Prevention /

When the ambient air temperature falls below 32°F, the water in a cooling tower can freeze. *Marley Technical Report #H-003 “Operating Cooling Towers in Freezing Weather”* describes how to prevent freezing during operation. Ask your Marley sales representative for a copy or download from our website.

Water collects in the cold water basin during shutdowns, and may freeze solid. You can prevent freezing by adding heat to the water left in the tower. Or, you can drain the tower and all exposed piping at shutdown.

■ Electric Basin Heaters

Choose from two types of automatic basin heater systems, based on your site conditions and preferences.

You may choose a heater system consisting of these components (shipped separately for installation by others):

- Stainless steel electric immersion heater element(s). Threaded couplings are provided for installation.
- NEMA 4 enclosure containing these components:
 - Magnetic contactor to energize heater.
 - Transformer to convert power supply to 24 volts for control circuit.
 - Solid state circuit board for heater control and low-water cut-off.
 Enclosure may be mounted on the side of the tower.
- Control probe to monitor water temperature and water level. Threaded couplings are provided for installation.

Or you may prefer a pre-assembled submersible tank-type heater which requires no tower modification and can plug into a standard grounded 3-prong 120V outlet.

The Incoloy heater element was chosen for its long life in submerged environments. A built-in thermostat senses water temperature and controls the supply of electricity to maintain proper water temperature. A built-in safety switch cuts off power whenever the element is exposed to air. The element mounts in the tower basin on a stainless steel plate.

Any exposed piping that is still filled with water at shutdown—including the makeup water line—should be electrically traced and insulated (by others).

■ Indoor Tank Method

In this type of system, water flows from an indoor tank, through the load system, and back to the tower, where it is cooled. The cooled water flows by gravity from the tower to the tank located in a heated space. At shutdown, all exposed water drains into the tank, where it is safe from freezing.

The table on page 11 lists typical drain-down capacities for all Aquatower models. Although we do not produce tanks, many of our representatives offer tanks supplied by reputable manufacturers.

The amount of water needed to successfully operate the system depends on the tower size, GPM and the volume of water contained in the piping system to and from the tower. You must select a tank large enough to contain those combined volumes—plus a level sufficient to maintain a flooded suction on your pump. Control makeup water according to the level where the tank stabilizes during operation.

You should always use a bottom outlet for this type of piping system. The following table lists the flow capacities for bottom outlets.

Basin Heater Selection				
Model	+10° F Ambient		-10° F Ambient	
	Tank Heater	Component Heater	Tank Heater	Component Heater
490A	1.5 kw	3 kw	1.5 kw	3 kw
490B				
492A	1.5 kw	3 kw	1.5 kw	3 kw
492B				
493A	1.5 kw	3 kw	2@ 1.5 kw	3 kw
493B				
494A	2@ 1.5 kw	3 kw	2@ 1.5 kw	3 kw
494B				
494C				
495A	2@ 1.5 kw	3 kw	3@ 1.5 kw	4.5 kw
495B				
496A	3@ 1.5 kw	4.5 kw	4@ 1.5 kw	6 kw
496B				

1. Required kw is the amount of heat needed to maintain +40°F basin water temperature at the indicated ambient air temperature.
2. Tank heaters shown are 120 volts, single-phase.
3. Component heaters shown are 480 volts, three-phase. Options or special heater selections may add several weeks to delivery.
4. Heaters do not operate continuously. Heaters cycle on and off automatically as basin water temperature dictates.
5. Contact your Marley sales representative for selections appropriate for other ambient conditions than those shown here.

/ Field Assembly /

Drain-Down Capacity		
Model	Range of Tower Design GPM	Maximum Drain-Down gal
490A 490B	15 – 26	28
	27 – 51	30
	52 – 85	33
	86 – 153	36
492A 492B	21 – 53	49
	54 – 92	54
	93 – 151	60
	152 – 211	65
493A 493B	33 – 83	77
	84 – 144	84
	145 – 238	94
	239 – 328	101
494A 494B 494C	60 – 141	134
	142 – 227	145
	228 – 376	162
	377 – 563	178
495A 495B	82 – 192	182
	193 – 270	192
	271 – 513	219
	514 – 763	241
496A 496B	104 – 196	228
	197 – 286	243
	287 – 497	271
	498 – 963	320

Volumes shown are maximums for the GPM ranges indicated. Actual volumes will usually be less. Contact your local Marley sales representative for more specific information.

Maximum Bottom Outlet GPM				
Tower Model	Outlet Diameter			
	4"	6"	8"	10"
492AB–492B	120	225	225	
493A–493B	120	270	350	
494A–494B–494C	140	310	550	625
495A–495B	140	310	550	850
496A–496B	140	310	550	860

1. Maximum GPM applies to both pump and gravity flow piping systems. The outlet piping on gravity flow systems must have sufficient vertical drop to overcome all other head losses in the system.
2. Bottom outlet is not available on Models 490A and 490B.

Note: For economical transportation, Aquatowers are normally packaged unassembled when shipped from the US by sea or air freight.

■ Field Assembly

If you choose to assemble your Aquatower at the job site, your Aquatower will be shipped unassembled with complete assembly instructions.

The following table shows the sizes and weights of the largest Aquatower components for each model. You can use this information to plan your rigging and transportation needs.

Unassembled tower shipment may add 3 to 5 weeks to normal lead times. Your Marley sales representative will be glad to help you plan for your unique needs.

Component Sizes and Weights			
Model	Component	Size in	Weight lb
490A 490B	Collection Basin End	12 x 13 x 36	15
	Collection Basin Floor	3 x 30 x 32	23
	Front Panel	2 x 36 x 44	21
	Casing	2 x 40 x 52	43
	Distribution Basin	8 x 16 x 32	18
492A 492B	Collection Basin End	14 x 16 x 48	24
	Collection Basin Floor	3 x 36 x 44	37
	Front Panel	2 x 48 x 68	52
	Casing	2 x 26 x 63	34
493A 493B	Distribution Basin	8 x 16 x 44	24
	Collection Basin End	14 x 16 x 72	37
	Collection Basin Floor	3 x 36 x 68	56
	Front Panel	2 x 37 x 72	35
494A 494B 494C	Casing	2 x 26 x 63	34
	Distribution Basin	8 x 16 x 68	37
	Collection Basin End	18 x 18 x 72	47
	Collection Basin Floor	4 x 34 x 68	56
495A 495B	Front Panel	2 x 44 x 72	41
	Casing	2 x 40 x 76	63
	Distribution Basin	8 x 28 x 68	52
	Discharge Hood Side	2 x 41 x 77	37
496A 496B	Discharge Hood Floor	9 x 45 x 68	46
	Collection Basin End	18 x 18 x 96	63
	Collection Basin Floor	4 x 34 x 92	75
	Front Panel	2 x 44 x 96	56
496A 496B	Casing	2 x 40 x 76	63
	Distribution Basin	8 x 28 x 92	70
	Discharge Hood Side	2 x 41 x 77	37
	Discharge Hood Floor	9 x 45 x 63	41
496A 496B	Collection Basin End	18 x 18 x 120	79
	Collection Basin Floor	4 x 34 x 116	95
	Front Panel	2 x 46 x 120	71
	Casing	2 x 40 x 84	69
	Distribution Basin	8 x 28 x 116	88
	Discharge Hood Side	2 x 45 x 77	38
	Discharge Hood Floor	9 x 45 x 77	54

/ Specifications /

Base: Furnish and install an induced-draft, crossflow, factory-assembled, steel cooling tower of ____ cell(s), as shown on plans. Tower shall be similar and equal in all respects to Marley Series 4900 Aquatower, Model _____. Tower must be warranted by the manufacturer for one year from date of shipment.

Performance: Tower shall cool ____ GPM of water from ____ °F to ____ °F at a design entering air wet-bulb temperature of ____ °F and its thermal rating shall be certified by the Cooling Technology Institute.

Construction: Structural components of the tower, including the cold water basin, framework, mechanical equipment supports, casing, hot water basin, and fan cylinder shall be fabricated of heavy-gauge steel, protected against corrosion by G-235 galvanizing per ASTM A-653. All components subjected to factory welding shall be hot dip galvanized after fabrication per ASTM A-123. Cold galvanizing is not acceptable.

Motor: Motor(s) shall be ____ hp, Totally Enclosed, specially insulated for cooling tower duty. Speed and electrical characteristics shall be 1800 (or 1800/900) RPM, single-winding, ____ phase, ____ hertz, ____ volts. The motor must be located out of the saturated discharge air stream.

Mechanical Equipment: Fan(s) shall be adjustable-pitch propeller type. Fan shall be driven through V-belt(s) with a minimum service factor of 1.5 based on full motor hp and protected with a belt guard. The fan and fan pulley shall be supported by oil lubricated tapered roller bearings in a cast iron housing with externally accessible remote oil reservoir for easy maintenance.

Fill, Louvers and Drift Eliminator: Fill shall be film-type, thermoformed PVC, with louvers and drift eliminator formed as part of each fill sheet. Fill shall be suspended from hot dip galvanized structural tubing supported from the upper tower structure, and shall be elevated above the floor of the cold water basin to facilitate cleaning. Air inlet faces of the tower shall be free of water splash-out. Guaranteed drift losses shall not exceed 0.005% of the design GPM.

Hot Water Distribution System: An open basin above the fill bank shall receive hot water piped to each cell of the tower. The basins shall be equipped with removable covers to keep out debris. This basin shall be installed and sealed at the factory. Water shall enter the basin through a removable wave-suppressor splash box. The basin shall be no less than 6 3/8" deep to provide adequate freeboard against overflow and splash-out. Removable and replaceable polypropylene nozzles installed in the floor of the basin shall provide full coverage of the fill by gravity flow. Nozzles must all have the same orifice size and be spaced symmetrically in both longitudinal and transverse directions.

Cold Water Basin and Accessories: The cold water basin shall be factory sealed. For maximum installation flexibility, basin accessories shall include both a side suction connection and a hole and bolt circle in the basin floor suitable for gravity flow. Both connections shall include a debris screen and anti-cavitation device. A factory-installed, float-operated, mechanical makeup valve shall be included, having a 3/4" diameter inlet connection.

SPX Cooling Technologies

Balcke | Hamon Dry Cooling | Marley

/ 7401 W 129 Street // Overland Park, KS USA 66213 // +1 913 664 7400 // spxcooling@ct.spx.com // www.spxcooling.com /

In the interest of technological progress, all products are subject to design and/or material change without notice
©2005 SPX Cooling Technologies, Inc. | Printed in USA

AQ-05A