

Rotary heat exchangers

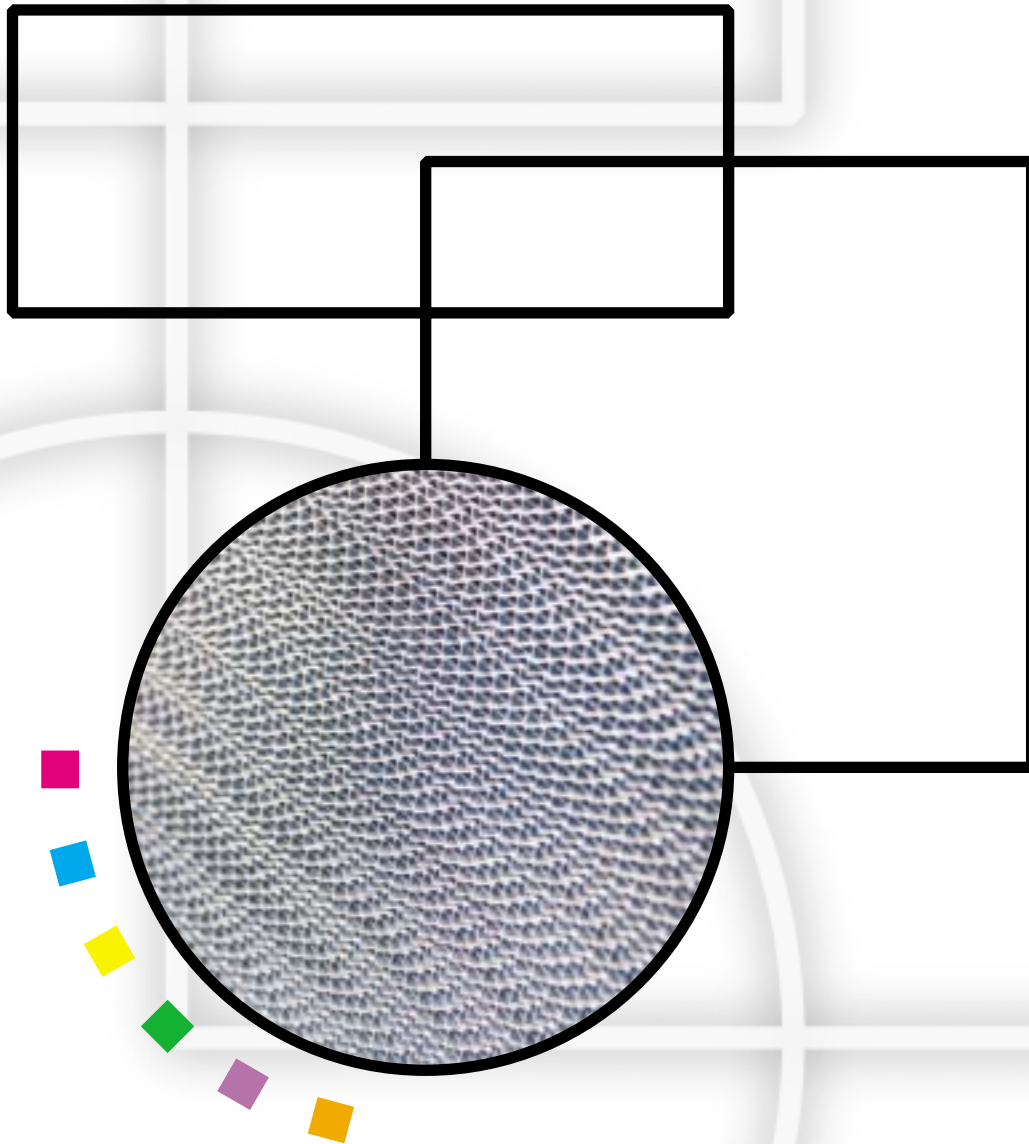

**COOKE
INDUSTRIES**

Auckland (Head Office)
31 Station Road, Penrose, Auckland, NZ
PO Box 12021, Penrose, Auckland 1135
Ph: +64-9-579 2185 Fax: +64-9-579 2181

Web: www.cookeindustries.co.nz

Christchurch
Level 3, 161 Kilmore Street, Christchurch, NZ
PO Box 17709, Sumner, Christchurch 8008
Ph: +64-3-379 7884 Fax: +64-3-379 7874

Email: sales@cookeindustries.co.nz

RECUPERATOR





Introduction

Among the available energy recovery systems, the rotary heat exchangers ensure the best efficiency, ranging from 60% to 90%, depending upon operating conditions. This because of their very large exchange surface in proportion to their volume.

The installed power of a plant is considerably reduced with the high efficiency of the rotary heat exchangers and with the possibility of recovering the humidity as well as the heat (hygroscopic wheel).

In addition, the possibility of recovering humidity enables the humidifiers effect to be reduced.

The chief component of the machine is its wheel. Available in various materials, this usually consists of aluminium sheets, which are alternately flat and corrugated. The result of this is that a series of passages is created through which the two air-flows move in opposite directions.

The Working Principle

In rotary heat exchangers, thermal exchange takes place through the accumulation of heat in the wheel; thus, while the rotor rotates slowly, the exhaust air moves across half of the unit and transfers heat to the matrix of the wheel, which accumulates it. Supply air crossing the other half absorbs the heat accumulated. Continuing rotation the parts that absorb and impart heat invert, so this process can go on indefinitely.

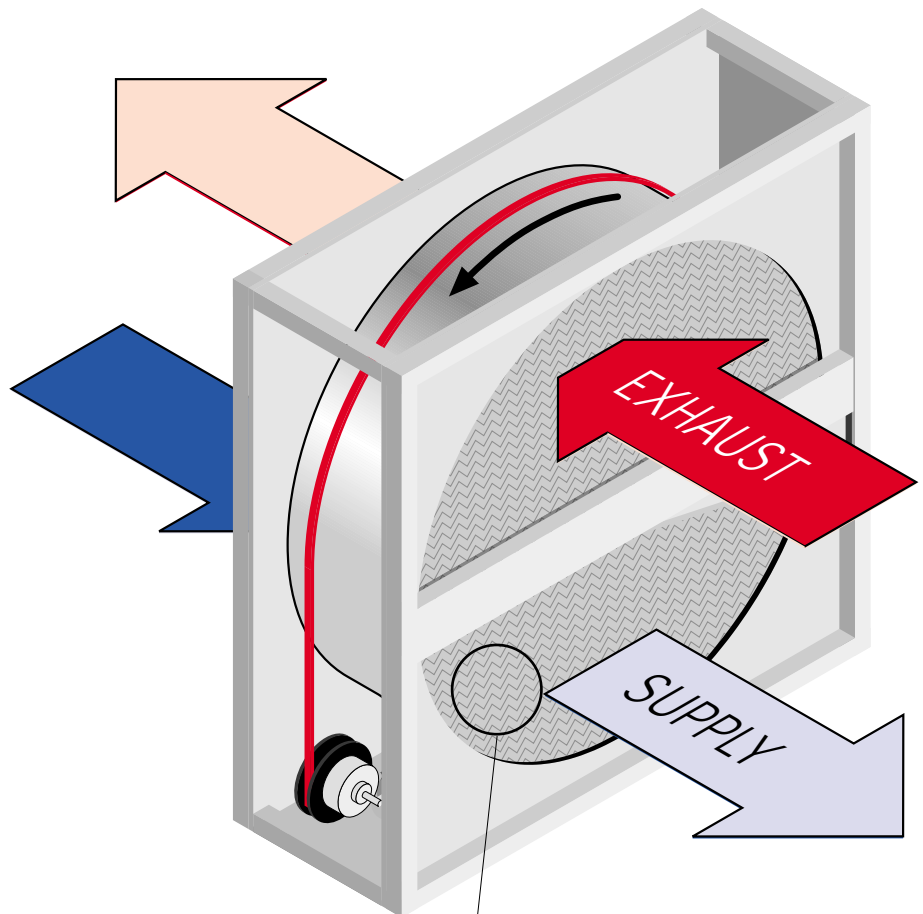



Main Features

Vertical and horizontal position ensures maximum fitting flexibility for installation in the ducts or in the air handling units.

Low leakage between the two air-streams ensured by the use of brushes made of synthetic fibre, mounted on the perimeter of the wheel and on the casing.

Variety of Material
The wheel is made of aluminium sheeting and pre-painted aluminium (epoxy coated); for the materials the standard hygroscopic version, the high-efficiency hygroscopic type, and the version for protection against a marine environment are available, in accordance with the table on Page 5.

Wide Range of Models
The dimensions of the complete heat exchanger range from 600 mm up to 2500 mm, in 100 mm steps, thus catering for applications with air capacities of up to about 44,000 m³/h.

Drive equipment
Available for operation at constant speed or else variable speed, with a speed controller – see Page 9.

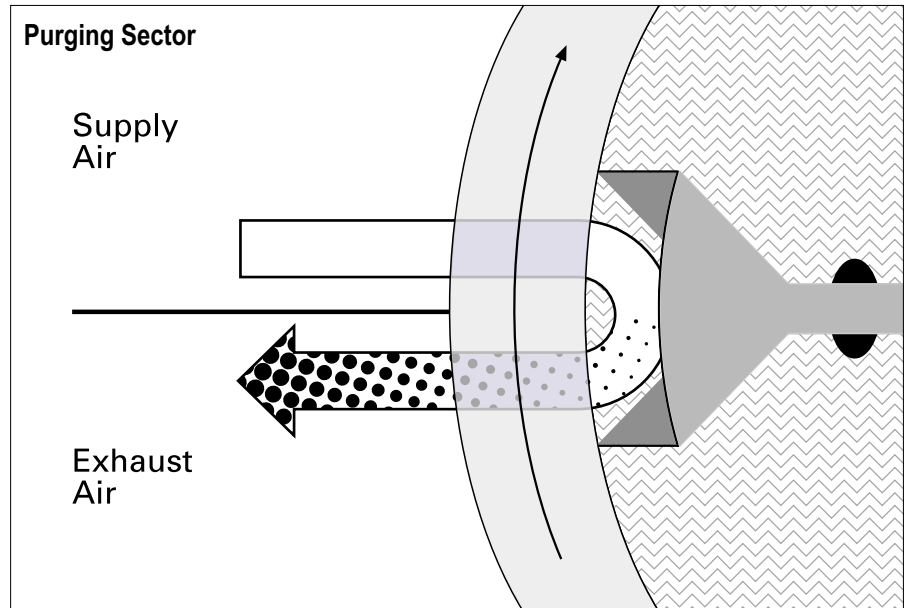

Purging sector
This enables the wheel to be kept clean continuously, by using a small amount of supply clean air. During rotation, the exhaust air soils the wheel and might contaminate the fresh air after half a rotation. To eliminate this, the heat exchanger is provided with a purging sector on the supply air input side, downstream of the wheel, at the point at which the wheel shifts from expulsion on to input. The purging sector has to be positioned in such a way that the pressure of the new air is higher than that of the air expelled. Thus a certain amount of new air can be transferred to the exhaust ducts, making it possible to clean the wheel itself.

Positioning
8 different configurations are available (for both vertical and horizontal installation) for positioning the motor and the direction of the air-flows (see Page 9).

Spacing
Changing the well height of the sheets of corrugated aluminium three different densities for the wheel are created.

Temperature Range
Depending on the models, the maximum limit ranges from 70°C to 100°C.

Wheel Options

- Wheel with increased thickness
- Wheel with reduced depth
- Wheel divided into sections

Frame Options

- Frame with side panels
- Frame with special dimensions adaptable to existing plant





Product code

Tx AL 07 N v3 M K AT TC...

T = Series

x = Commercial group

AL = Material

AL: aluminium
AC: pre-painted aluminium

07 = Model

from 06 to 25

N = Temperature range

N: 70°C
D: 100°C

v = Installation

v: vertical
h: horizontal

3 = Positioning

1, 2, 3, 4, 5, 6, 7, 8 (see Page 9)

M = Well height

C: close well height
M: medium well height
L: large well height

K = Drive equipment

K: constant speed, 400 V motor
T: constant speed, 400 V motor with thermal contact
V: 230 V motor with thermal contact for speed controller
R: variable speed, 230 V motor and speed controller

AT TC ... = Options

Material

AT: hygroscopic treatment
AR: hygroscopic treatment, high efficiency
AS: protective treatment for marine environment

Wheel

XS: wheel with increased thickness
XP: wheel with reduced depth (100 mm)
XD: wheel divided into sections

Casing

TC: casing with panels
TS: casing with special dimensions
TN: without casing (wheel only)



Options		Models		
		from 06 to 10	from 11 to 15	from 16 to 25
Material	AT	■	■	■
	AR	■	■	■
	AS	■	■	■
Wheel	XS	■	■	■
	XP	■	■	
	XD		■	■
Casing	TC	■	■	■
	TS	■	■	■
	TN	■	■	■

Material

AT

Hygroscopic treatment
Wheel with absorbent matrix in aluminium alloy, coated in inorganic non-crystalline hygroscopic material for transferring latent heat.
Max. operating temperature: 70°C

AR

High-efficiency hygroscopic treatment
Wheel with absorbent matrix in aluminium alloy, coated in special hygroscopic material for enhanced transfer of latent heat.
Max. operating temperature 70°C

AS

Treatment for marine environment
Wheel made of aluminium salt proof alloy. Resistant to saline atmosphere
Max. operating temperature: 100°C

Wheel

XS

Increased thickness
Wheel made in various versions as regards material, with sheeting 0.10 mm thick. Suitable for applications involving high differential pressure.

XP

Reduced depth
Wheel made in various versions as regards material, with a reduced depth of 100 mm. Suitable for applications calling for very low pressure drop.

XD

Division into sections
Wheel made in various versions as regards material, in sectorized sections. Suitable for special applications such as replacement of old wheels in confined space, transport problems, etc.

Casing*

TC

Side panels
Casing made with sections and side panels in galvanized sheeting. Front panel is dismantlable. Suitable for ducts installation or to replace the module of the air handling unit.

TS

Special dimensions
For the standard version and for the one with side panels (TC), the height of the frame can be varied (height H), depending on the customer's requirements.

TN

Wheel only
Only the wheel is available, with all the options provided for in this catalogue.

* The standard casing consists of sections in galvanized sheeting, without side panels. Suitable for insertion inside air handling units.





Materials

The following table shows the possible combinations with the various materials and their options; for example, a rotary heat exchanger may be made of pre-painted aluminium [AC] with only the hygroscopic treatment [AT], or else with the same treatment and sheeting of increased thickness [XS]. Obviously, the basic versions [AL or AC], can be made without treatments or options.

	AT	AS	XS	AR
AL				
	■			
				■
	■	■		
	■	■	■	
		■		
		■	■	
			■	
AC				
	■			
	■	■		
	■	■	■	

AL

Standard aluminium

Wheel in aluminium alloy

Max. operating temperature: 70°C

Standard depth: 200 mm

AC

Coated aluminium

Wheel made of aluminium alloy, coated with anti-corrosion paint.

Max. operating temperature: 100°C

Standard depth: 200 mm



Selection

The following table is for rapid selection of the required heat exchanger.

Efficiency (%)	77,7	68,6	59,7
Pressure drop (Pa)	80	150	250

Model	Ø mm	H=A mm	Air flow m³/h		
			700	1200	1900
06	500	600	700	1200	1900
07	600	700	1000	1750	2750
08	700	800	1400	2400	3750
09	800	900	1800	3100	4850
10	900	1000	2300	4000	6250
11	1000	1100	2800	4900	7700
12	1100	1200	3400	6000	9300
13	1200	1300	4000	7100	11000
14	1300	1400	4700	8300	13000
15	1400	1500	5500	9600	15000
16	1500	1600	6200	11100	17300
17	1600	1700	7000	12600	19700
18	1700	1800	8000	14200	22200
19	1800	1900	9000	16000	25000
20	1900	2000	10200	17700	27600
21	2000	2100	11300	19600	30500
22	2100	2200	12500	21600	33500
23	2200	2300	13900	24000	37000
24	2300	2400	15100	26000	40500
25	2400	2500	16500	28500	44000

The above performance figures may be considered broadly indicative and may vary, depending on working conditions. For a correct technical assessment, Recuperator provides you with the REX computer program. Upon request, a program (DLL), for incorporation in that of the air handling unit manufacturers, is also available.





Dimensions

Standard version, frame in galvanized steel.

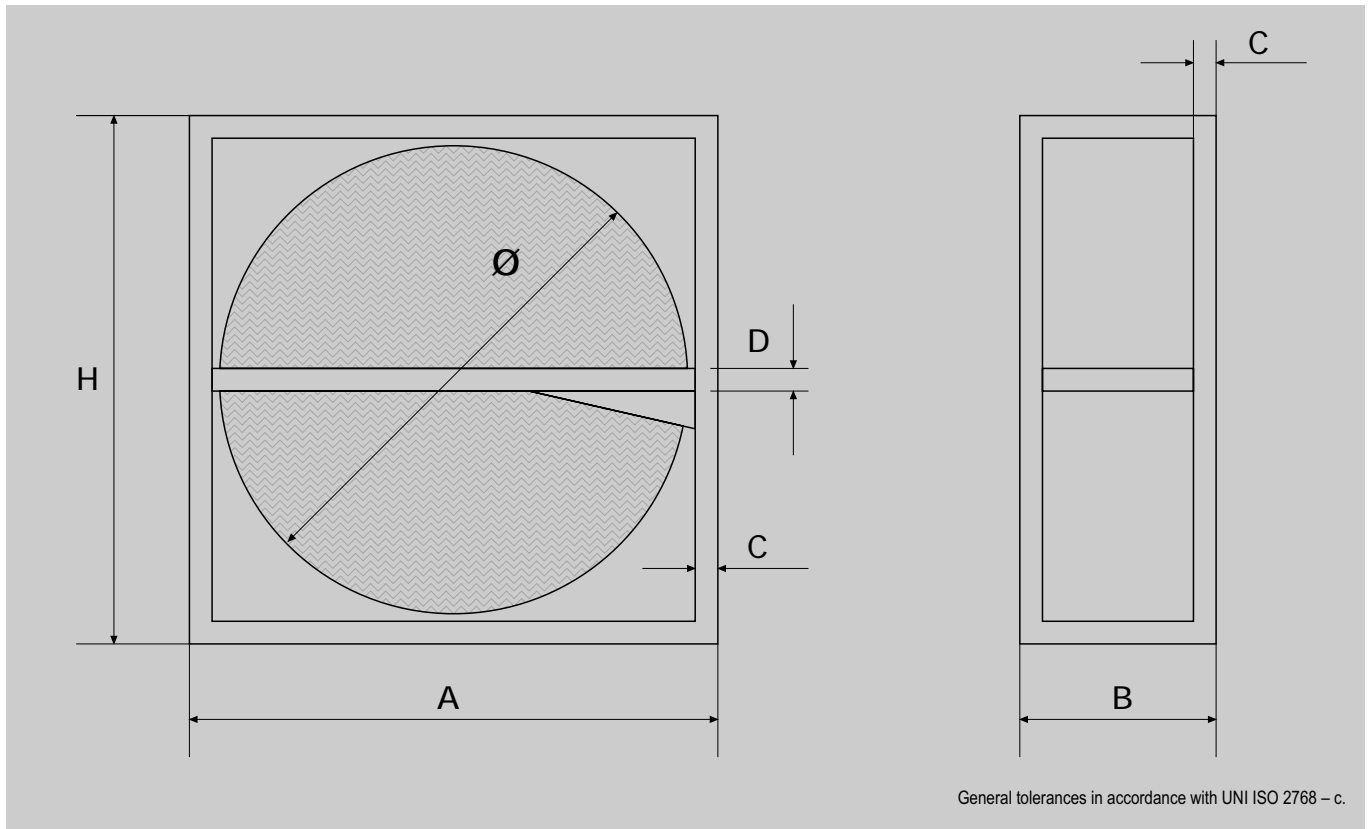

Model	Ø mm	A mm	H mm	B mm	C mm	D mm	Weight kg
06	500	600	600	290	30	60	26
07	600	700	700	290	30	60	34
08	700	800	800	290	30	100	43
09	800	900	900	290	30	100	52
10	900	1000	1000	290	30	100	63
11	1000	1100	1100	290	30	100	75
12	1100	1200	1200	290	30	100	89
13	1200	1300	1300	290	30	100	104
14	1300	1400	1400	290	30	100	114
15	1400	1500	1500	290	30	100	135
16	1500	1600	1600	290	30	100	152
17	1600	1700	1700	290	30	60	170
18	1700	1800	1800	290	30	60	191
19	1800	1900	1900	290	30	60	212
20	1900	2000	2000	290	30	60	233
21	2000	2100	2100	290	30	60	255
22	2100	2200	2200	290	30	60	278
23	2200	2300	2300	290	30	60	303
24	2300	2400	2400	290	30	60	328
25	2400	2500	2500	290	30	60	355



Dimensions

Version with side panels (option TC), frame in galvanized steel.
The frame can be supplied complete or in two sections.

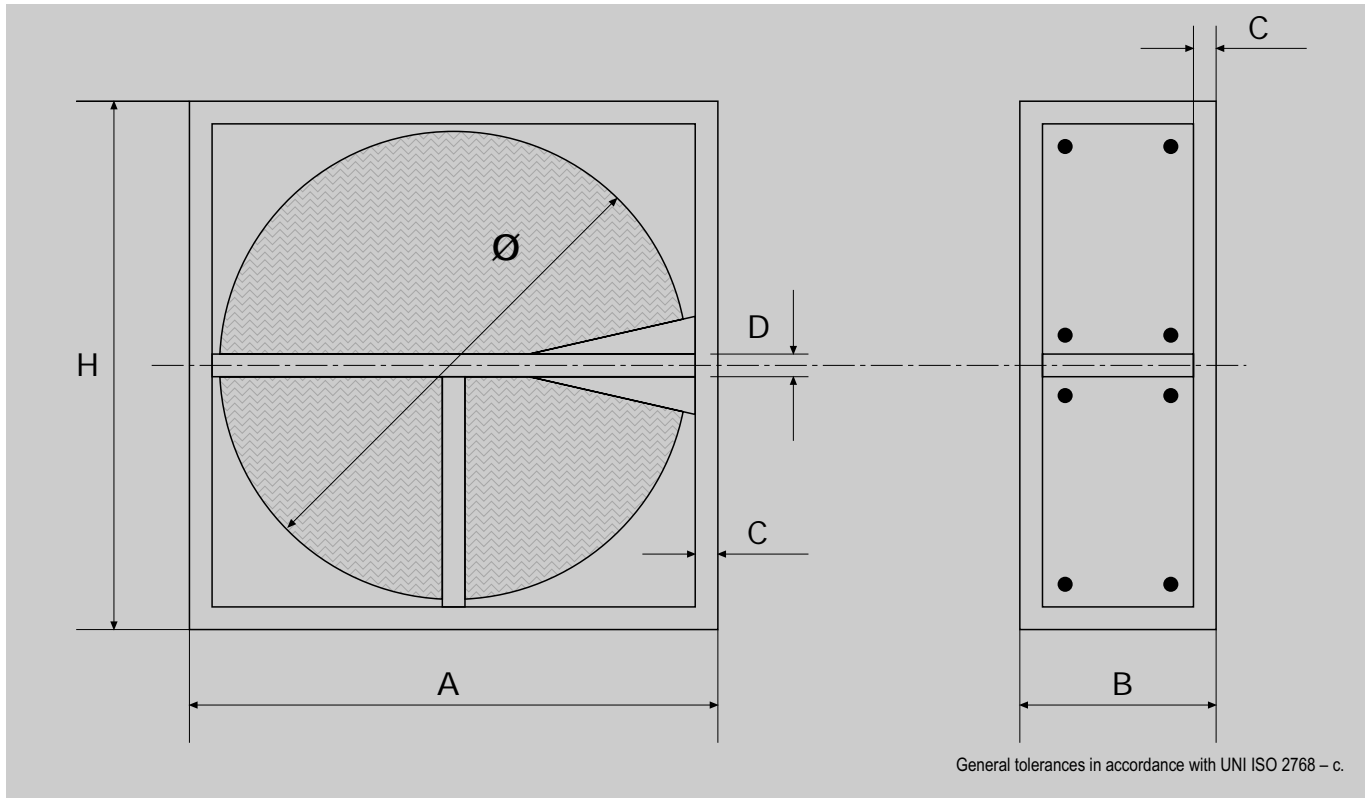

Model	Ø mm	A mm	H mm	B mm	C mm	D mm	Weight kg
06	500	640	640	390	30	50	46
07	600	740	740	390	30	50	56
08	700	840	840	390	30	50	67
09	800	940	940	390	30	50	79
10	900	1040	1040	390	50	50	92
11	1000	1180	1180	390	50	50	108
12	1100	1280	1280	390	50	50	123
13	1200	1380	1380	390	50	50	140
14	1300	1480	1480	390	50	50	156
15	1400	1580	1580	390	50	50	174
16	1500	1680	1680	390	50	50	192
17	1600	1780	1780	390	50	70	212
18	1700	1880	1880	390	50	70	234
19	1800	1980	1980	390	50	70	255
20	1900	2080	2080	390	50	70	277
21	2000	2220	2220	430	70	70	303
22	2100	2320	2320	430	70	70	328
23	2200	2420	2420	430	70	70	352
24	2300	2520	2520	430	70	70	378
25	2400	2620	2620	430	70	70	405



Positioning

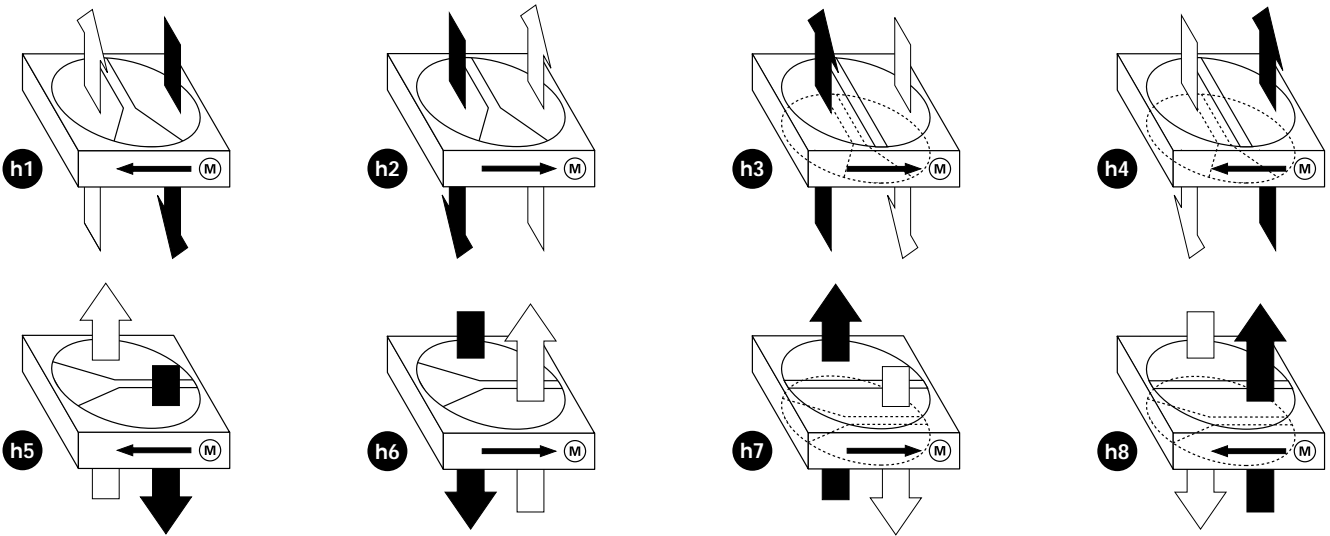
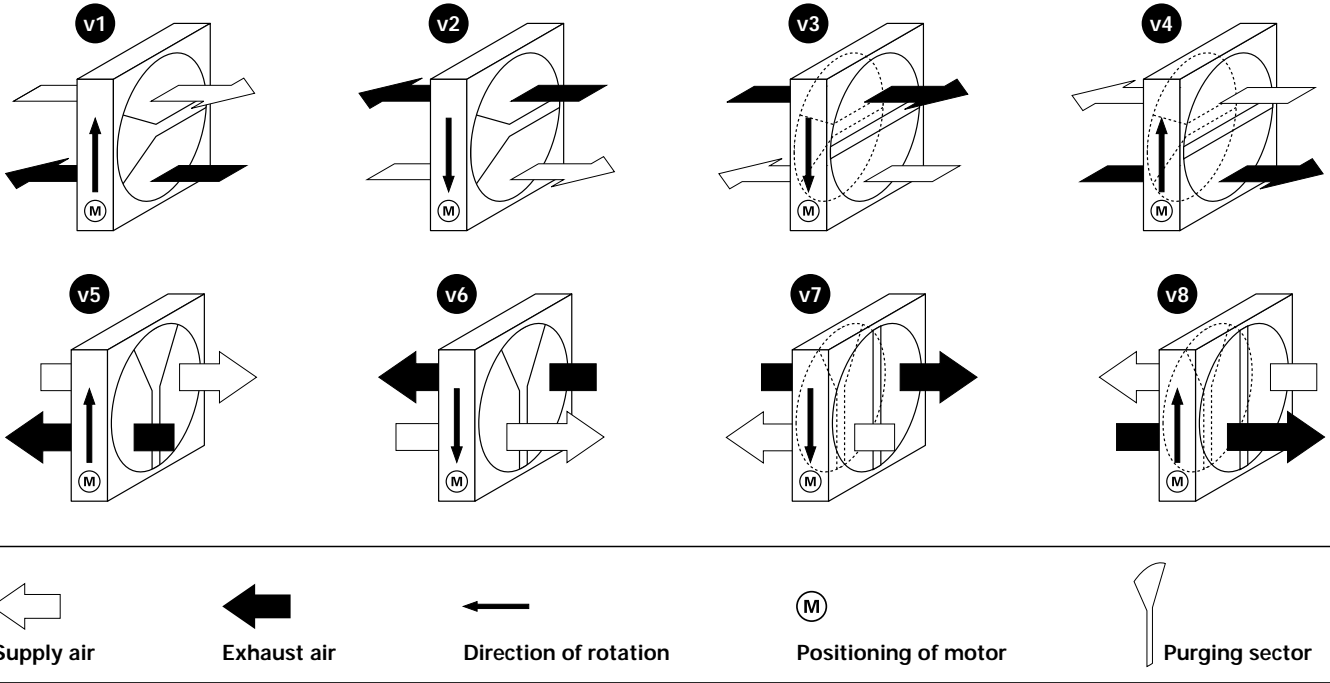

Drive equipment

We now give a table summarizing the features of the used motors, depending on the type of drive. The diagrams for connecting up the motors and the speed controller are to be found inside the assembly manual supplied together with the exchangers, with instructions for use and maintenance.

	Variable-speed drive				Constant-speed drive			
	500-1000	1001-1400	1401-2300	2301-2400	500-1000	1001-1100	1101-1600	1601-2400
Ø wheel (mm)	500-1000	1001-1400	1401-2300	2301-2400	500-1000	1001-1100	1101-1600	1601-2400
Voltage (V)	230	230	230	230	400	400	400	400
Frequency (Hz)	50/60	50/60	50/60	50/60	50/60	50/60	50/60	50/60
Power (kW)	0,025	0,09	0,18	0,37	0,025	0,09	0,18	0,37
Current (A)	0,24	0,70	0,99	1,82	0,24	0,70/0,40	0,99/0,57	1,82/1,05

Lainate office

From A8 Motorway, to Milan and the Lakes

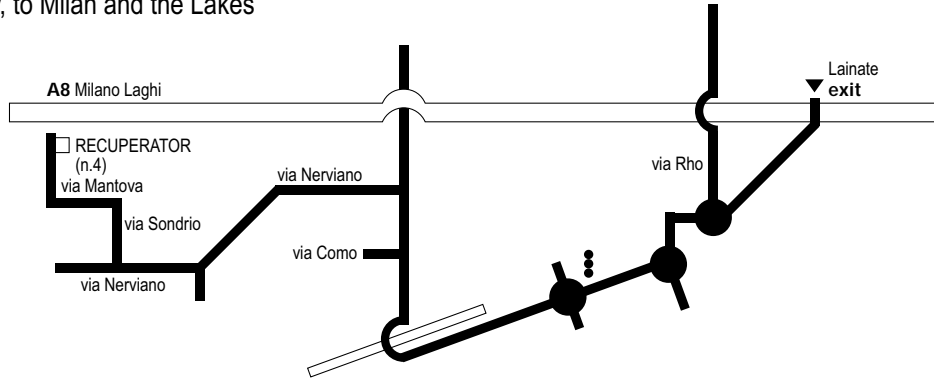

Inveruno office

From A4 Motorway, to Turin and Trieste

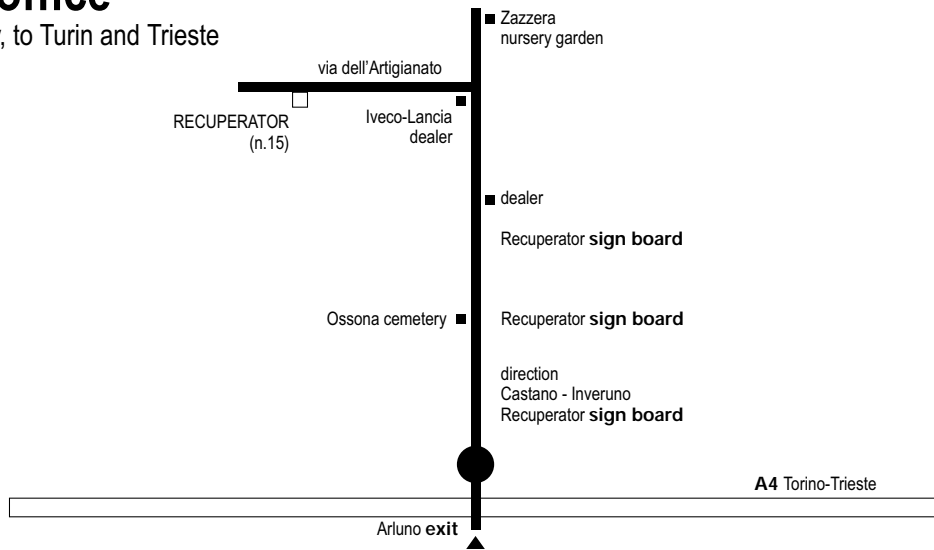

From Lainate to Inveruno

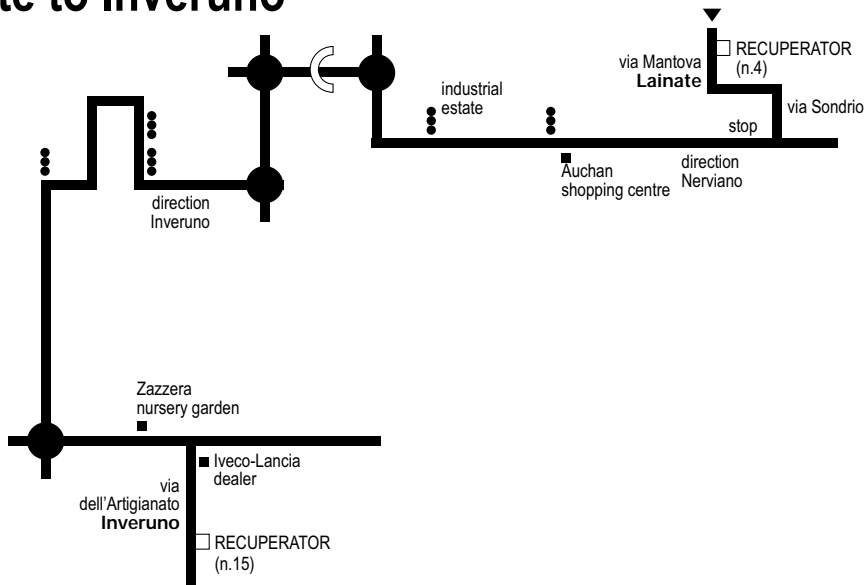

RECUPERATOR

