

BRAZED PLATE HEAT EXCHANGERS

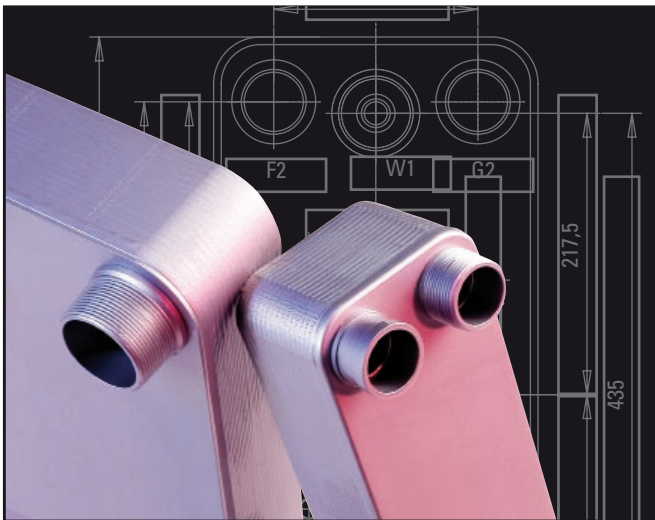

THERMOKEY

CODICE SCAMBIATORI A PIASTRE
Braze Plate Heat Exchangers code

X 009 040 AA 0 0000

Carattere fisso / Fixed data

Modello es. / Item i.e.: TP09, TP12, TP82, ecc

Numero Piastre / Plates no.

Combinazione / tipologia attacchi (vedi pag. 15)
Configuration / connections no. (see page 15)

Impiego / Operating:

0 = serie normale/condensatore - 1 = serie D con distributori/evaporatore
2 = serie H altapressione - 3 = serie HD altapressione con distributori
0 = standard / condensator - 1 = D serie with distributor / evaporator
2 = H serie for High Pressure - 3 = HD for High Pressure with distributor

Solo per bicircuiti / Only for Double Circuit:

4 = serie I incrociata - 5 = serie ID incrociata con distributore
6 = serie IH incrociata altapressione - 7 = serie IHD incrociata altapressione con distributori
4 = I serie for Cross circuit - 5 = ID serie for High Pressure with distributor
6 = IH for High Pressure with Cross circuit - 7 = IHD for High Pressure with Cross circuit and distributor

Progressivo numerico che identifica i tipi e le combinazioni dei raccordi

Progressive number to identify size & type connections

DESCRIZIONE CODICE PIASTRE:
Braze Plate Heat Exchangers code description

BPHE TP82 D 90 F1=ODS22 W1=G1"1/4CM BW1=G1"1/4CML F2=ODS35 W2=G1"1/4CM BW2=G1"1/4CML

Identificazione Scambiatori a Piastre / Fixed data

Modello es. / Item i.e.: TP09, TP12, TP82, ecc

Esecuzione - Utilizzo Scambiatore

Operating condition :

vuoto = serie normale/condensatore
D = serie con distributori/evaporatore - H = serie altapressione
HD = serie altapressione con distributori
Empty space = standard / condensator
D = distributor / evaporator serie - H = High Pressure serie
HD = High Pressure with distributor serie

Numero Piastre / Plates no.

Tipo attacchi / Connections type:

ODS..... = attacchi a saldare + dimensione tubo
VIC..... = attacco flessibile + dimensione
RTLK..... = attacco rotalock + dimensione
G..... CM = attacchi filettati + dimensione filetto + tipo filettatura
ODS.... = Outer soldering pipe diameter
VIC.... = Flexible Joint and pipe diameter
RTLK... = Rotalock type and outer soldering pipe diameter
G....CM = Size and type pipe thread

NB: TIPO FILETTATURA/THREDDING TYPE

J = filetto conico C = filetto cilindrico + M = filetto maschio + F = filetto femmina + L = attacco lungo + C = attacco corto Vuoto = attacco normale
J = Conical C = Cylindrical + M = Male + F = Female + L = Long length connection + C = Short length connection Empty space = standard

VERSIONE NORMALE STANDARD / STANDARD NORMAL VERSION

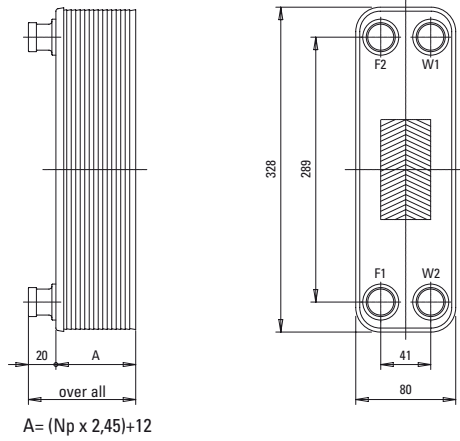

$$A = (N_p \times 2,45) + 12$$

ACCESSORI POSSIBILI/OPTIONAL ON REQUEST

DA SPECIFICARE IN FASE D'ORDINE/TO BE SPECIFIED ON ORDER

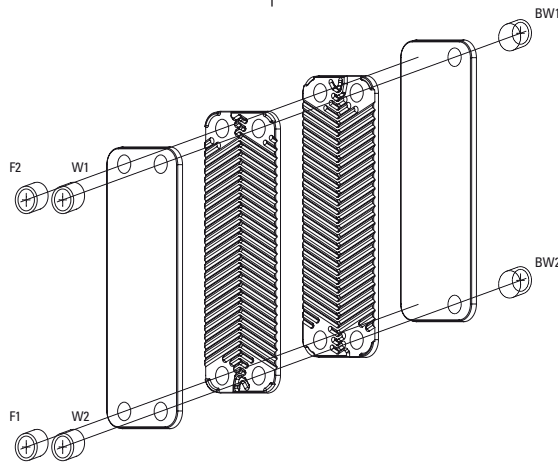
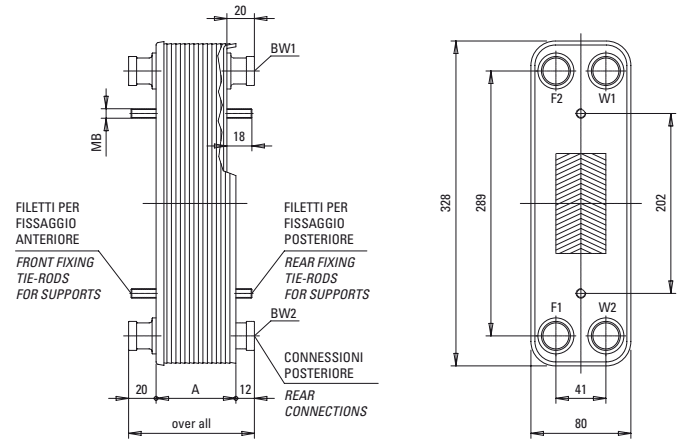

DATI TECNICI - TECHNICAL DATA

VERSIONE / VERSION		TP09 (R410A)			
POTENZA "in condizioni standard di lavoro"	CAPACITY (nominal conditions)	12 kW			
		Circuito - Circuit			
PRESSIONE MASSIMA DI LAVORO	MAXIMUM ALLOWABLE WORKING PRESSURE	50°C	F1-F2: 46 bar	W1-W2: 47 bar	
		120°C	F1-F2: 36 bar	W1-W2: 37 bar	
		300°C	F1-F2: 26 bar	W1-W2: 27 bar	
TEMPERATURA MINIMA DI LAVORO	MIN. DESIGN TEMPERATURE	- 100 °C (-148 °F)			
TEMPERATURA MASSIMA DI LAVORO	MAX DESIGN TEMPERATURE	+ 300 °C (+572 °F)			
NUMERO DI PIASTRE "NP"	NUMBER OF PLATES	min.: 8 max: 50			
NUMERO DI CAMERE	NUMBER PER CHAMBER	Circ./Circuit side F1-F2: (NP/2-1)	Circ./Circuit side W1-W2: (NP/2)		
VOLUME PER CAMERA	VOLUME PER CHAMBER	0.0474 litri/liters			
PORTATA MASSIMA	TOTAL FLOW RATE m ³ /h			
PESO COMPLESSIVO "P"	TOTAL WEIGHT	P=Np x 0.09 + 1 kg			
CONNESSIONE STANDARD CIRCUITO	STANDARD CONNECTION FOR CIRCUIT	F1:	ODS 18	F2:	ODS 22
		W1:	G 1/2" Conico/Conical	W2:	G 1/2" Conico/Conical
CONNESSIONI A RICHIESTA "Da specificare in fase d'ordine"	CONNECTION REQUIRED "To be specified on order"	ODS 9.5	G 1/2" Cilindrico/Cylindrical	Rotalock 3/4"	
		ODS 14	G 1/2" Femmina/Female	Rotalock 1"	
			G 3/4" Cilindrico/Cylindrical		

MATERIALI - MATERIALS

MATERIALE PIASTRA DI SCAMBIO:	PLATE HEAT EXCHANGER MATERIAL:	1.4401 - EN10028/7 "AISI 316L"
MATERIALE CONNESSIONI:	CONNECTIONS MATERIAL:	1.4401 - EN10028/7 "AISI 316L"
MATERIALE BRASANTE:	BRAZING MATERIAL:	RAME PURO / COPPER - Cu -

VERSIONE NORMALE STANDARD / STANDARD NORMAL VERSION

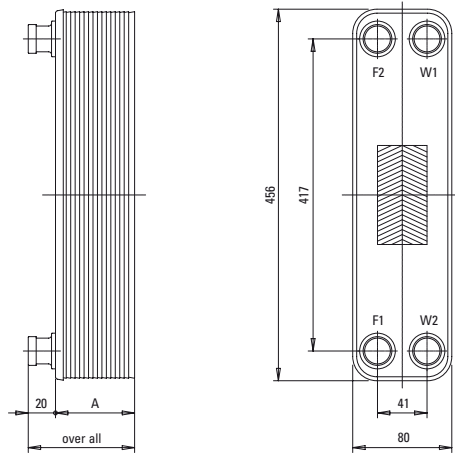

$A = (Np \times 2,45) + 12$ (versione/version TP22 normale/normal)

$A = (Np \times 2,45) + 20$ (versione/version TP22H alta pressione/high pressure)

ACCESSORI POSSIBILI/OPTIONAL ON REQUEST

DA SPECIFICARE IN FASE D'ORDINE/TO BE SPECIFIED ON ORDER

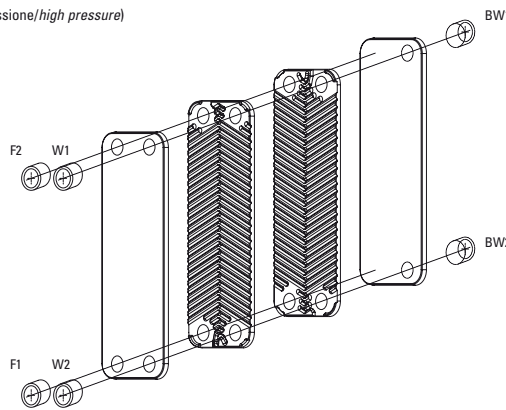
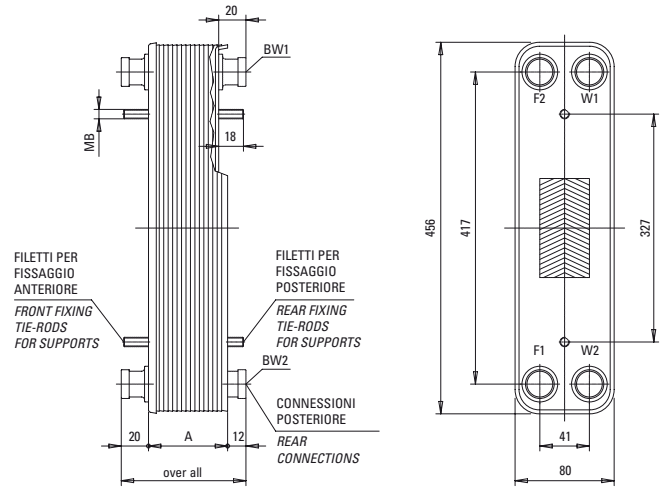

DATI TECNICI - TECHNICAL DATA

VERSIONE / VERSION		TP22		TP22 H (R410A)		
POTENZA "in condizioni standard di lavoro"	CAPACITY (nominal conditions)	28 kW				
		Circuito - Circuit				
PRESSIONE MASSIMA DILAVORO	MAXIMUM ALLOVABLE WORKING PRESSURE	50°C	F1-F2: 37 bar	W1-W2: 25 bar	F1-F2: 47 bar	W1-W2: 45 bar
		120°C	F1-F2: 29 bar	W1-W2: 20 bar	F1-F2: 37 bar	W1-W2: 35 bar
		300°C	F1-F2: 21 bar	W1-W2: 14 bar	F1-F2: 27 bar	W1-W2: 26 bar
TEMPERATURA MINIMA DI LAVORO	MIN. DESIGN TEMPERATURE	- 100 °C (-148 °F)				
TEMPERATURA MASSIMA DI LAVORO	MAX DESIGN TEMPERATURE	+ 300 °C (+572 °F)				
NUMERO DI PIASTRE "NP"	NUMBER OF PLATES	min.: 8		max: 60		
NUMERO DI CAMERE	NUMBER PER CHAMBER	Circ./Circuit side F1-F2: (NP/2-1)		Circ./Circuit side W1-W2: (NP/2)		
VOLUME PER CAMERA	VOLUME PER CHAMBER	0,0649 litri/liters				
PORTATA MASSIMA	TOTAL FLOW RATE m ³ /h				
PESO COMPLESSIVO "P"	TOTAL WEIGHT	P=Np x 0.13 + 1,5 kg		P=Np x 0.13 + 3,5 kg		
CONNESSIONE STANDARD CIRCUITO	STANDARD CONNECTION FOR CIRCUIT	F1:	ODS 18	F2:	ODS 22	
		W1:	G 1/2" Conico/ Conical	W2:	G 1/2" Conico/ Conical	
CONNESSIONI A RICHIESTA "Da specificare in fase d'ordine"	CONNECTION REQUIRED "To be specified on order"	ODS 9,5	G 1/2" Cilindrico/ Cylindrical	G 1/2" Femmina/Female		
		ODS 14	G 3/4" Conico/ Conical	Rotalock 3/4"		
			G 3/4" Cilindrico/ Cylindrical	Rotalock 1"		

MATERIALI - MATERIALS

MATERIALE PIASTRA DI SCAMBIO:	PLATE HEAT EXCHANGER MATERIAL:	1.4401 - EN10028/7 "AISI 316L"
MATERIALE CONNESSIONI:	CONNECTIONS MATERIAL:	1.4401 - EN10028/7 "AISI 316L"
MATERIALE BRASANTE:	BRAZING MATERIAL:	RAME PURO / COPPER- Cu -

VERSIONE NORMALE STANDARD / STANDARD NORMAL VERSION

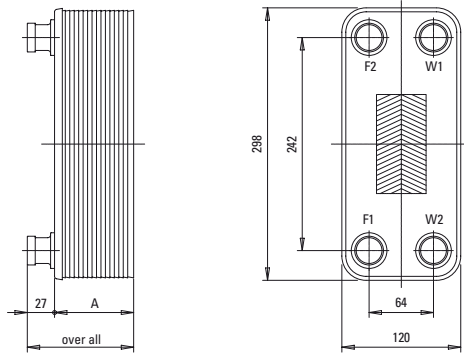

$A = (N_p \times 2,45) + 12$ (versione/version TP12 normale/normal)
 $A = (N_p \times 2,45) + 20$ (versione/version TP12H alta pressione/high pressure)

ACCESSORI POSSIBILI/OPTIONAL ON REQUEST

DA SPECIFICARE IN FASE D'ORDINE/TO BE SPECIFIED ON ORDER

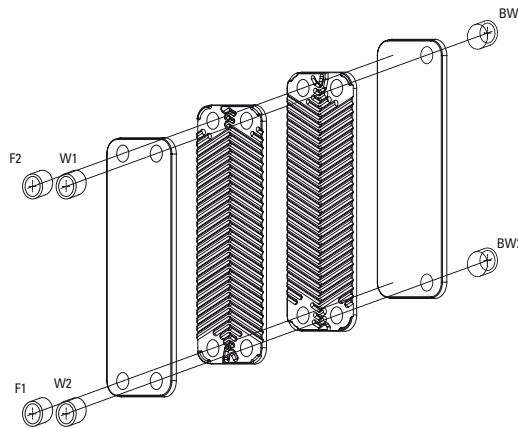
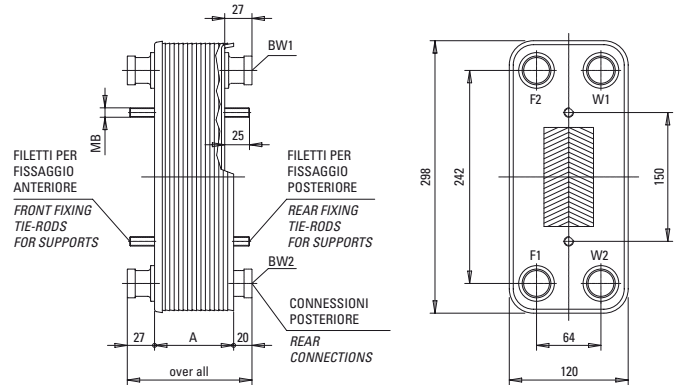

DATI TECNICI - TECHNICAL DATA

VERSIONE / VERSION		TP12		TP12 H (R410A)		
POTENZA "in condizioni standard di lavoro"	CAPACITY (nominal conditions)	30 kW				
		Circuito - Circuit				
PRESSIONE MASSIMA DI LAVORO	MAXIMUM ALLOVABLE WORKING PRESSURE	50°C	F1-F2: 40 bar	W1-W2: 38 bar	F1-F2: 53 bar	W1-W2: 56 bar
		120°C	F1-F2: 31 bar	W1-W2: 30 bar	F1-F2: 42 bar	W1-W2: 44 bar
		300°C	F1-F2: 23 bar	W1-W2: 22 bar	F1-F2: 31 bar	W1-W2: 32 bar
TEMPERATURA MINIMA DI LAVORO	MIN. DESIGN TEMPERATURE	- 100 °C (-148 °F)				
TEMPERATURA MASSIMA DI LAVORO	MAX DESIGN TEMPERATURE	+ 300 °C (+572 °F)				
NUMERO DI PIASTRE "NP"	NUMBER OF PLATES	min.: 8		max: 60		
NUMERO DI CAMERE	NUMBER PER CHAMBER	Circ./Circuit side F1-F2: (NP/2-1)		Circ./Circuit side W1-W2: (NP/2)		
VOLUME PER CAMERA	VOLUME PER CHAMBER	0,0708 litri/liters				
PORTATA MASSIMA	TOTAL FLOW RATE m³/h				
PESO COMPLESSIVO "P"	TOTAL WEIGHT	P=Np x 0.112 + 1,7 kg		P=Np x 0.112 + 4 kg		
		F1: ODS 22	F2: ODS 28			
CONNESSIONE STANDARD CIRCUITO	STANDARD CONNECTION FOR CIRCUIT	W1: G 1" Conico/ Conical		W2: G 1" Conico/ Conical		
		ODS 35	G 1/2" Femmina/Female G 1" Cilindrico/ Cylindrical G 1" 1/4" Conico/ Conical	G 1" 1/4 Cilindrico/ Cylindrical DN32 1" 1/4 Flexible Joint Rotalock (a richiesta) - (on request)		
CONNESSIONI A RICHIESTA "Da specificare in fase d'ordine"	CONNECTION REQUIRED "To be specified on order"					

MATERIALI - MATERIALS

MATERIALE PIASTRA DI SCAMBIO:	PLATE HEAT EXCHANGER MATERIAL:	1.4401 - EN10028/7 "AISI 316L"
MATERIALE CONNESSIONI:	CONNECTIONS MATERIAL:	1.4401 - EN10028/7 "AISI 316L"
MATERIALE BRASANTE:	BRAZING MATERIAL:	RAME PURO / COPPER- Cu -

VERSIONE NORMALE STANDARD / STANDARD NORMAL VERSION

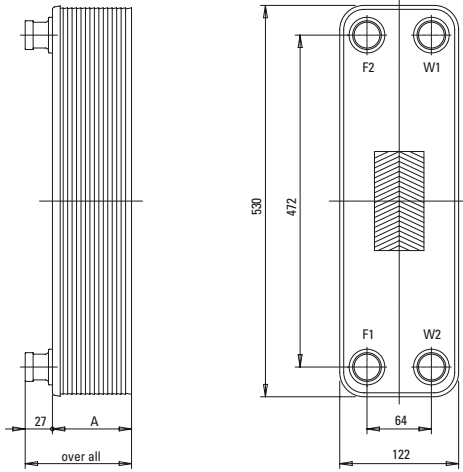

$A = (N_p \times 2,45) + 12$ (versione/version TP82-TP82D normale/normal)

$A = (N_p \times 2,45) + 20$ (versione/version TP82H-TP82DH alta pressione/high pressure)

ACCESSORI POSSIBILI/OPTIONAL ON REQUEST

DA SPECIFICARE IN FASE D'ORDINE/TO BE SPECIFIED ON ORDER

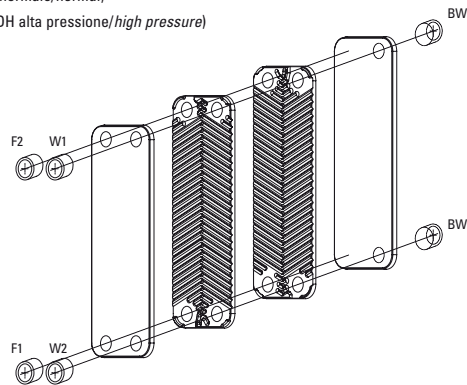
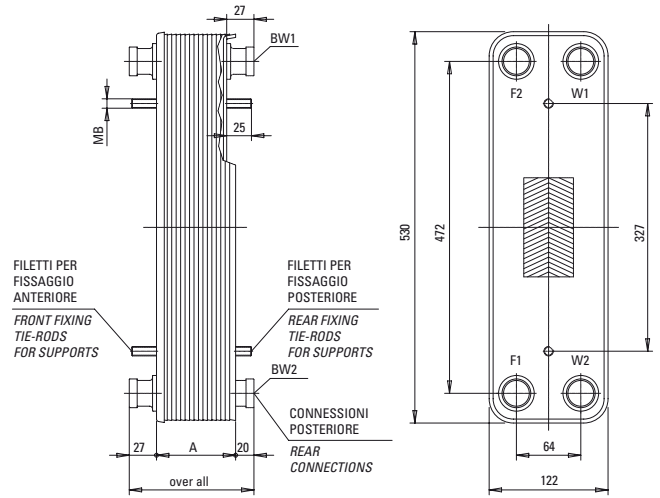

DATI TECNICI - TECHNICAL DATA

VERSIONE / VERSION		TP82 - TP82D		TP82H - TP82HD (R410A)		
POTENZA "in condizioni standard di lavoro"	CAPACITY (nominal conditions)	85 kW				
		Circuito - Circuit				
PRESSIONE MASSIMA DI LAVORO	MAXIMUM ALLOWABLE WORKING PRESSURE	50°C	F1-F2: 46 bar	W1-W2: 40 bar	F1-F2: 57 bar	W1-W2: 52 bar
		120°C	F1-F2: 36 bar	W1-W2: 31 bar	F1-F2: 45 bar	W1-W2: 41 bar
		300°C	F1-F2: 26 bar	W1-W2: 23 bar	F1-F2: 33 bar	W1-W2: 30 bar
TEMPERATURA MINIMA DI LAVORO	MIN. DESIGN TEMPERATURE	- 100 °C (-148 °F)				
TEMPERATURA MASSIMA DI LAVORO	MAX DESIGN TEMPERATURE	+ 300 °C (+572 °F)				
NUMERO DI PIASTRE "NP"	NUMBER OF PLATES	min.: 8		max: 120		
NUMERO DI CAMERE	NUMBER PER CHAMBER	Circ./Circuit side F1-F2: (NP/2-1)		Circ./Circuit side W1-W2: (NP/2)		
VOLUME PER CAMERA	VOLUME PER CHAMBER	0,115 litri/liters				
PORTATA MASSIMA	TOTAL FLOW RATE	... m³/h				
PERO COMPLESSIVO "P"	TOTAL WEIGHT	P=Np x 0.206 + 2,5 kg		P=Np x 0.206 + 6,5 kg		
CONNESSIONE STANDARD CIRCUITO	STANDARD CONNECTION FOR CIRCUIT	F1:	ODS 22	F2:	ODS 35	
		W1:	G 1" 1/4 Conico/ Conical	W2:	G 1" 1/4 Conico/ Conical	
CONNESSIONI A RICHIESTA "Da specificare in fase d'ordine"	CONNECTION REQUIRED "To be specified on order"	ODS 28	G 1/2" Femmina/Female	DN 32	1" 1/4 Flexible Joint	
			G 1" Conico/ Conical	DN 40	1" 1/2 Flexible Joint	
			G 1" Cilindrico/Cylindrical		Rotalock (a richiesta) - (on request)	
			G 1" 1/4 Cilindrico/Cylindrical			

MATERIALI - MATERIALS

MATERIALE PIASTRA DI SCAMBIO:	PLATE HEAT EXCHANGER MATERIAL:	1.4401 - EN10028/7 "AISI 316L"
MATERIALE CONNESSIONI:	CONNECTIONS MATERIAL:	1.4401 - EN10028/7 "AISI 316L"
MATERIALE BRASANTE:	BRAZING MATERIAL:	RAME PURO / COPPER- Cu -

TP202

SCAMBIATORI A PIASTRE PLATE HEAT EXCHANGERS

VERSIONE NORMALE STANDARD / STANDARD NORMAL VERSION

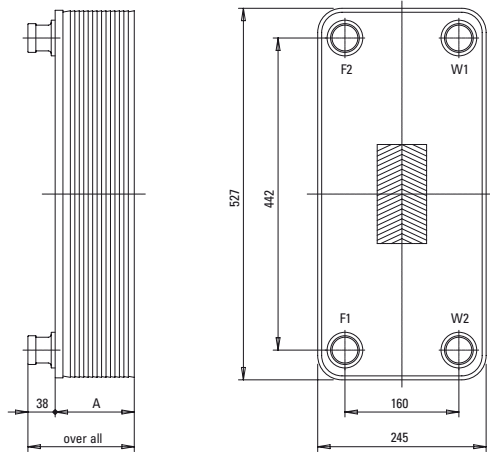

$$A = (N_p \times 2,45) + 12 \text{ (versione TP202-TP202D)}$$

$$A = (N_p \times 2,45) + 28 \text{ (versione TP202H-TP202DH)}$$

ACCESSORI POSSIBILI/OPTIONAL ON REQUEST

DA SPECIFICARE IN FASE D'ORDINE/TO BE SPECIFIED ON ORDER

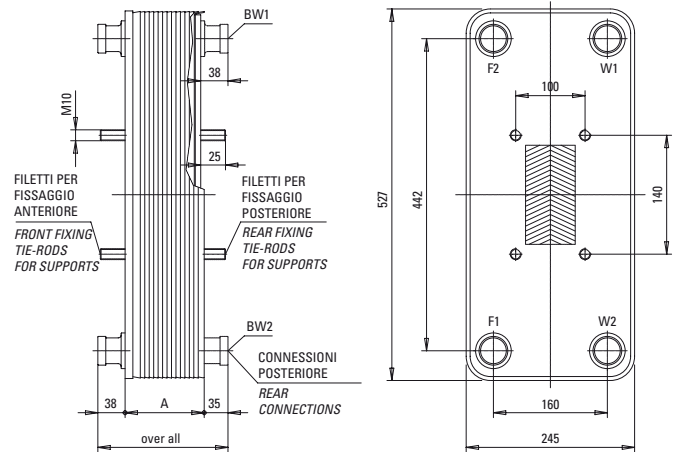

NB: POSSIBILE ANCHE KIT DI SUPPORTO/ SUPPORT KIT AVAILABLE

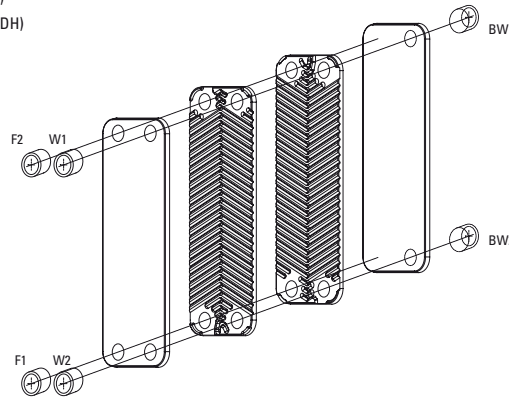

DATI TECNICI - TECHNICAL DATA

VERSIONE / VERSION		TP202 - TP202D		TP202H - TP202HD (R410A)		
POTENZA "In condizioni standard di lavoro"	CAPACITY (nominal conditions)	220 kW				
		Circuito - Circuit				
PRESSIONE MASSIMA DI LAVORO	MAXIMUM ALLOWABLE WORKING PRESSURE	50°C	F1-F2: 35 bar	W1-W2: 35 bar	F1-F2: 48 bar	W1-W2: 35 bar
		120°C	F1-F2: 27 bar	W1-W2: 27 bar	F1-F2: 37 bar	W1-W2: 27 bar
		300°C	F1-F2: 20 bar	W1-W2: 20 bar	F1-F2: 27 bar	W1-W2: 20 bar
TEMPERATURA MINIMA DI LAVORO	MIN. DESIGN TEMPERATURE	- 100 °C (-148 °F)				
TEMPERATURA MASSIMA DI LAVORO	MAX DESIGN TEMPERATURE	+ 300 °C (+572 °F)				
NUMERO DI PIASTRE "NP"	NUMBER OF PLATES	min.: 8		max.: 150		
NUMERO DI CAMERE	NUMBER PER CHAMBER	Circ./Circuit side F1-F2: (NP/2-1)		Circ./Circuit side W1-W2: (NP/2)		
VOLUME PER CAMERA	VOLUME PER CHAMBER	0,255 litri/liters				
PORTATA MASSIMA	TOTAL FLOW RATE	... m ³ /h				
PESO COMPLESSIVO "P"	TOTAL WEIGHT	P=Np x 0.406 + 9,2 kg		P=Np x 0.406 + 18 kg		
CONNESSIONE STANDARD CIRCUITO	STANDARD CONNECTION FOR CIRCUIT	F1:	ODS 35		F2:	ODS 54
		W1:	G 2" Conico/ Conical		W2:	G 2" Conico/ Conical
CONNESSIONI A RICHIESTA "Da specificare in fase d'ordine"	CONNECTION REQUIRED "To be specified on order"	G 1/2" Femmina/ Female		DN 50 2" Flexible Joint		
		G 1" 1/2 Conico/ Conical		DN 65 2" 1/2 Flexible Joint		
		G 1" 1/2 Cilindrico/ Cylindrical				
		G 2" Cilindrico/ Cylindrical				
		G 2" 1/2 Cilindrico/ Cylindrical				

MATERIALI - MATERIALS

MATERIALE PIASTRA DI SCAMBIO:	PLATE HEAT EXCHANGER MATERIAL:	1.4401 - EN10028/7 "AISI 316L"
MATERIALE CONNESSIONI:	CONNECTIONS MATERIAL:	1.4401 - EN10028/7 "AISI 316L"
MATERIALE BRASANTE:	BRAZING MATERIAL:	RAME PURO / COPPER - Cu -

VERSIONE NORMALE STANDARD / STANDARD NORMAL VERSION

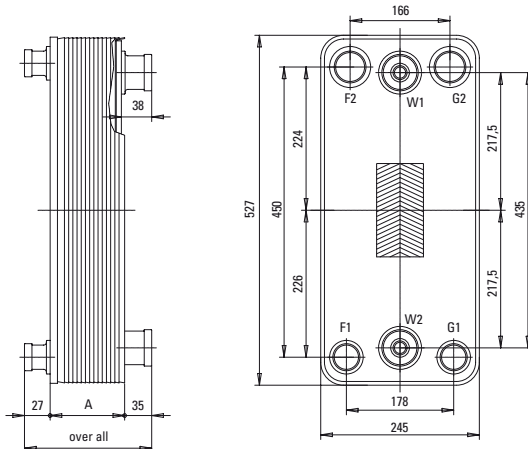

$$A = (Np \times 2,45) + 12 \text{ (versione/ version TP222-TP222D)}$$

$$A = (Np \times 2,45) + 28 \text{ (versione/ version TP222H-TP222DH)}$$

STANDARD

VERSIONE NORMALE / NORMAL VERSION

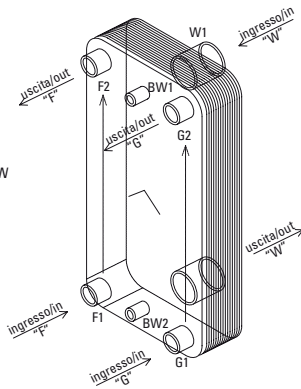

ACCESSORI POSSIBILI/OPTIONAL ON REQUEST

DA SPECIFICARE IN FASE D'ORDINE/TO BE SPECIFIED ON ORDER

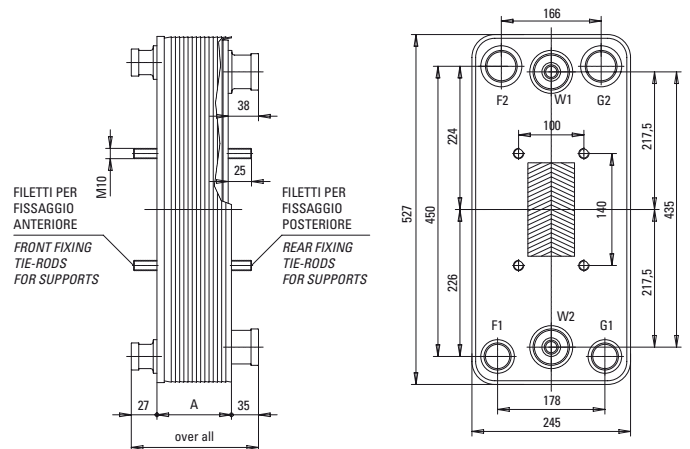

NB: POSSIBILE ANCHE KIT DI SUPPORTO/ SUPPORT KIT AVAILABLE

A RICHIESTA/ON REQUEST

VERSIONE INCROCIATA/CROSS VERSION

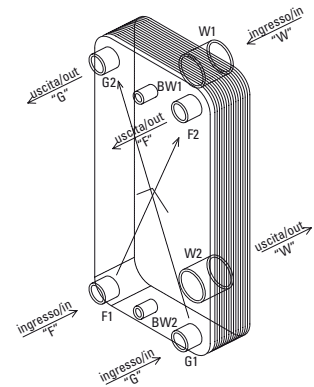

		DATI TECNICI - TECHNICAL DATA						
VERSIONE / VERSION		TP222 - TP222D				TP222H - TP222HD (R410A)		
POTENZA "in condizioni standard di lavoro"	CAPACITY (nominal conditions)	2x110 kW						
		Circuito - Circuit						
PRESSIONE MASSIMA DI LAVORO	MAXIMUM ALLOVABLE WORKING PRESSURE	50°C	F1-F2: 40 bar	G1-G2: 40 bar	W1-W2: 36 bar	F1-F2: 45 bar	G1-G2: 45 bar	W1-W2: 55 bar
		120°C	F1-F2: 31 bar	G1-G2: 31 bar	W1-W2: 28 bar	F1-F2: 35 bar	G1-G2: 35 bar	W1-W2: 43 bar
		300°C	F1-F2: 23 bar	G1-G2: 23 bar	W1-W2: 21 bar	F1-F2: 26 bar	G1-G2: 26 bar	W1-W2: 32 bar
TEMPERATURA MINIMA DI LAVORO	MIN. DESIGN TEMPERATURE	- 100 °C (-148 °F)						
TEMPERATURA MASSIMA DI LAVORO	MAX DESIGN TEMPERATURE	+ 300 °C (+572 °F)						
NUMERO DI PIASTRE "NP"	NUMBER OF PLATES	min.: 14		max: 210				
NUMERO DI CAMERE	NUMBER PER CHAMBER	Circ./Circuit side F1-F2: (NP/2-1)				Circ./Circuit side W1-W2: (NP/2)		
VOLUME PER CAMERA	VOLUME PER CHAMBER	0,227 litri/liters						
PORTATA MASSIMA	TOTAL FLOW RATE m³/h						
PESO COMPLESSIVO "P"	TOTAL WEIGHT	P=Np x 0.406 + 9,2 kg				P=Np x 0.406 + 18 kg		
CONNESSIONE STANDARD CIRCUITO	STANDARD CONNECTION FOR CIRCUIT	F1:	ODS 28				F2:	ODS 42
		G1:	ODS 28				G2:	ODS 42
		W1:	G 2" Cilindrico/ Cylindrical				W2:	G 2" Cilindrico/ Cylindrical
PORTATA SONDA	SENSOR POCKET	BW1:	G 1/2 Femmina/ Female				BW2:	G 1/2 Femmina/ Female
CONNESSIONI A RICHIESTA "Da specificare in fase d'ordine"	CONNECTION REQUIRED "To be specified on order"	F1 - F2 e G1 - G2:					W1 - W2:	
		ODS 22	G 3/4" Cilindrico/ Cylindrical				DN 50	2" Flexible Joint
		ODS 35	G 2" Conico/Conical				DN 65	2" 1/2 Flexible Joint
			G2" 1/2 Cilindrico/ Cylindrical					

MATERIALI - MATERIALS		
MATERIALE PIASTRA DI SCAMBIO:	PLATE HEAT EXCHANGER MATERIAL:	1.4401 - EN10028/7 "AISI 316L"
MATERIALE CONNESSIONI:	CONNECTIONS MATERIAL:	1.4401 - EN10028/7 "AISI 316L"
MATERIALE BRASANTE:	BRAZING MATERIAL:	RAME PURO / COPPER- Cu -

SCAMBIATORI A PIASTRE

TP09
12 kW

TP22
28 kW

TP12
30 kW

TP82
85 kW

TP202
220 kW

TP222
220 kW **dual circuit**



Ready for R410A

TP404
440 kW



TP424
440 kW dual circuit



TP606
660 kW



BRAZED PLATE HEAT EXCHANGERS

TP404

SCAMBIATORI A PIASTRE PLATE HEAT EXCHANGERS

VERSIONE NORMALE STANDARD / STANDARD NORMAL VERSION

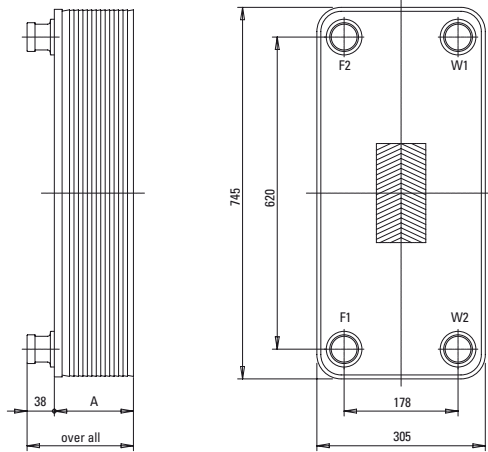

$$A = (N_p \times 2,95) + 12 \text{ (versione/ version TP404-TP404D)}$$

$$A = (N_p \times 2,95) + 28 \text{ (versione/ version TP404H-TP404DH)}$$

ACCESSORI POSSIBILI/OPTIONAL ON REQUEST

DA SPECIFICARE IN FASE D'ORDINE/TO BE SPECIFIED ON ORDER

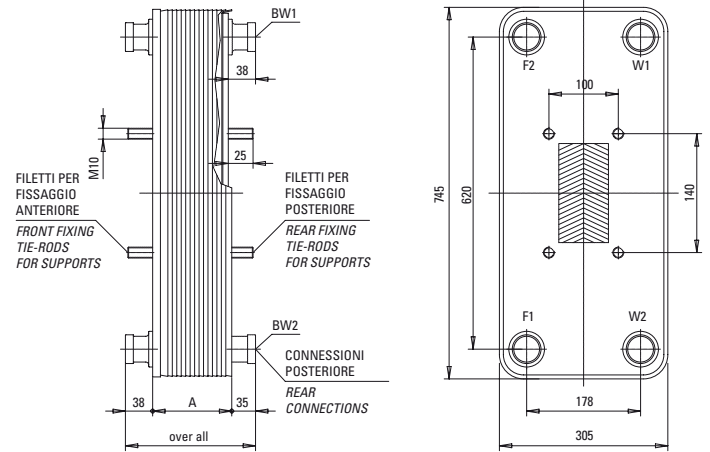

NB: POSSIBILE ANCHE KIT DI SUPPORTO/ SUPPORT KIT AVAILABLE

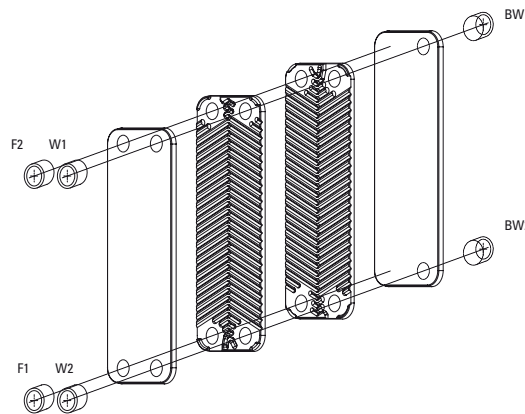

DATI TECNICI - TECHNICAL DATA

VERSIONE / VERSION		TP404 - TP404D			
POTENZA "in condizioni standard di lavoro"	CAPACITY (nominal conditions)	440 kW			
		Circuito - Circuit			
PRESSIONE MASSIMA LAVORO	MAXIMUM ALLOWABLE WORKING PRESSURE	50°C	F1-F2: 38 bar	W1-W2: 35 bar	
		120°C	F1-F2: 30 bar	W1-W2: 27 bar	
		300°C	F1-F2: 22 bar	W1-W2: 19 bar	
TEMPERATURA MINIMA DI LAVORO	MIN. DESIGN TEMPERATURE	- 100 °C (-148 °F)			
TEMPERATURA MASSIMA DI LAVORO	MAX DESIGN TEMPERATURE	+ 300 °C (+572 °F)			
NUMERO DI PIASTRE "NP"	NUMBER OF PLATES	min.: 20 max: 250			
NUMERO DI CAMERE	NUMBER PER CHAMBER	Circ./Circuit side F1-F2: (NP/2-1)		Circ./Circuit side W1-W2: (NP/2)	
VOLUME PER CAMERA	VOLUME PER CHAMBER	0,56 litri/liters			
PORTATA MASSIMA	TOTAL FLOW RATE	... m ³ /h			
PESO COMPLESSIVO "P"	TOTAL WEIGHT	P=Np x 0,720 + 30 kg			
CONNESSIONE STANDARD CIRCUITO	STANDARD CONNECTION FOR CIRCUIT	F1:	ODS 54	F2:	ODS 76
		W1:	G 3" Cilindrico/ Cylindrical	W2:	G 2" Cilindrico/ Cylindrical
CONNESSIONI A RICHIESTA "Da specificare in fase d'ordine"	CONNECTION REQUIRED "To be specified on order"	ODS 64	G 2" 1/2	DN 65	2" 1/2 Flexible Joint
				DN 80	3" Flexible Joint

MATERIALI - MATERIALS

MATERIALE PIASTRA DI SCAMBIO:	PLATE HEAT EXCHANGER MATERIAL:	1.4401 - EN10028/7 "AISI 316L"
MATERIALE CONNESSIONI:	CONNECTIONS MATERIAL:	1.4401 - EN10028/7 "AISI 316L"
MATERIALE BRASANTE:	BRAZING MATERIAL:	RAME PURO / COPPER- Cu -

VERSIONE NORMALE STANDARD / STANDARD NORMAL VERSION

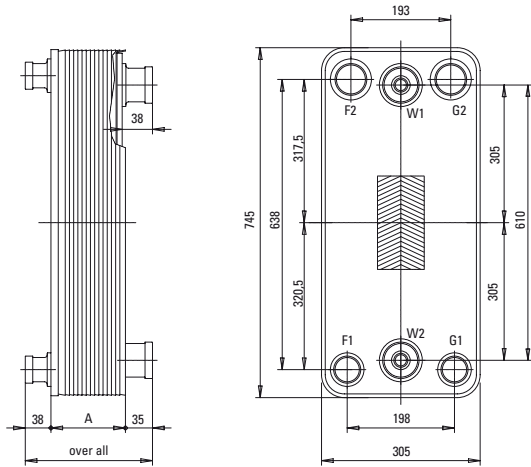

$A = (N_p \times 2,95) + 12$ (versione/ version TP424-TP424D)
 $A = (N_p \times 2,95) + 28$ (versione/ version TP424H-TP424DH)

STANDARD

VERSIONE NORMALE / NORMAL VERSION

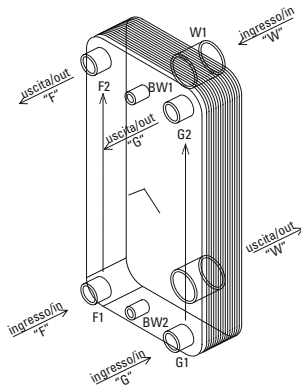

ACCESSORI POSSIBILI/OPTIONAL ON REQUEST

DA SPECIFICARE IN FASE D'ORDINE/TO BE SPECIFIED ON ORDER

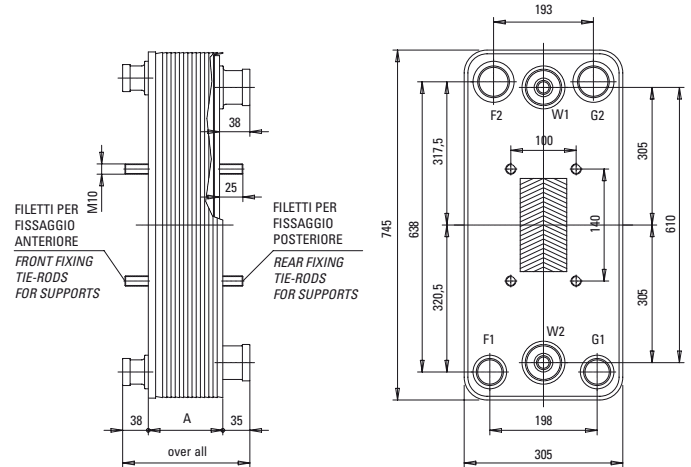

NB: POSSIBILE ANCHE KIT DI SUPPORTO/ SUPPORT KIT AVAILABLE

A RICHIESTA/ON REQUEST

VERSIONE INCROCIATA/CROSS VERSION

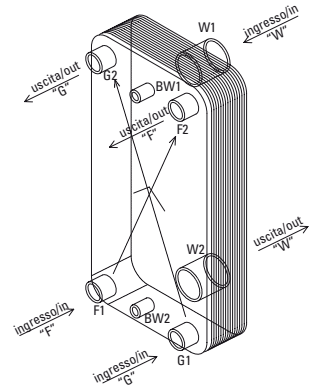

DATI TECNICI - TECHNICAL DATA

VERSIONE / VERSION		TP424 - TP424D			
POTENZA "in condizioni standard di lavoro"	CAPACITY (nominal conditions)	2x220 kW			
		Circuito - Circuit			
PRESSIONE MASSIMA DI LAVORO	MAXIMUM ALLOVABLE WORKING PRESSURE	50°C	F1-F2: 35 bar	G1-G2: 36 bar	W1-W2: 31 bar
		120°C	F1-F2: 27 bar	G1-G2: 28 bar	W1-W2: 24 bar
		300°C	F1-F2: 19 bar	G1-G2: 20 bar	W1-W2: 18 bar
TEMPERATURA MINIMA DI LAVORO	MIN. DESIGN TEMPERATURE	- 100 °C (-148 °F)			
TEMPERATURA MASSIMA DI LAVORO	MAX DESIGN TEMPERATURE	+ 300 °C (+572 °F)			
NUMERO DI PIASTRE "NP"	NUMBER OF PLATES	min.: 18 max: 252			
NUMERO DI CAMERE	NUMBER PER CHAMBER	Circ./Circuit side F1-F2: (NP/2-1)		Circ./Circuit side W1-W2: (NP/2)	
VOLUME PER CAMERA	VOLUME PER CHAMBER	0,486 litri/liters			
PORTATA MASSIMA	TOTAL FLOW RATE m ³ /h			
PESO COMPLESSIVO "P"	TOTAL WEIGHT	P=Np x 0.720 + 30 kg			
CONNESSIONE STANDARD CIRCUITO	STANDARD CONNECTION FOR CIRCUIT	F1:	ODS 54	F2:	ODS 54
		G1:	ODS 54	G2:	ODS 54
		W1:	G 3" Cilindrico/ Cylindrical	W2:	G 3" Cilindrico/ Cylindrical
PORTA SONDA	SENSOR POCKET	BW1:	G 1/2" Femmina/ Female	BW2:	G 1/2" Femmina/ Female
CONNESSIONI A RICHIESTA "Da specificare in fase d'ordine"	CONNECTION REQUIRED "To be specified on order"	ODS 64	G 3/4" Cilindrico/ Cylindrical	DN 65	2" 1/2 Flexible Joint
			G 2" 1/2 Cilindrico/ Cylindrical	DN 80	3" Flexible Joint

MATERIALI - MATERIALS

MATERIALE PIASTRA DI SCAMBIO:	PLATE HEAT EXCHANGER MATERIAL:	1.4401 - EN10028/7 "AISI 316L"
MATERIALE CONNESSIONI:	CONNECTIONS MATERIAL:	1.4401 - EN10028/7 "AISI 316L"
MATERIALE BRASANTE:	BRAZING MATERIAL:	RAME PURO / COPPER- Cu -

TP606

SCAMBIATORI A PIASTRE PLATE HEAT EXCHANGERS

VERSIONE NORMALE STANDARD / STANDARD NORMAL VERSION

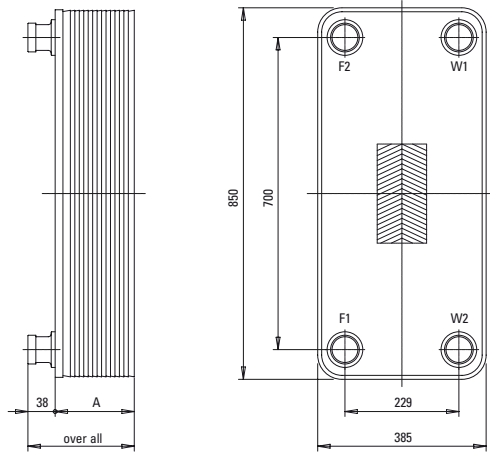

$$A = (N_p \times 2,95) + 12 \text{ (versione/version TP606-TP606D)}$$

$$A = (N_p \times 2,95) + 28 \text{ (versione/version TP606H-TP606DH)}$$

ACCESSORI POSSIBILI/OPTIONAL ON REQUEST

DA SPECIFICARE IN FASE D'ORDINE/TO BE SPECIFIED ON ORDER

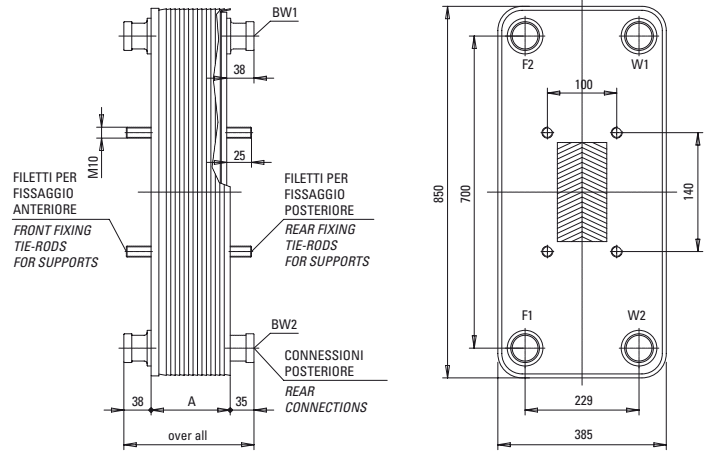

NB: POSSIBILE ANCHE KIT DI SUPPORTO/ SUPPORT KIT AVAILABLE

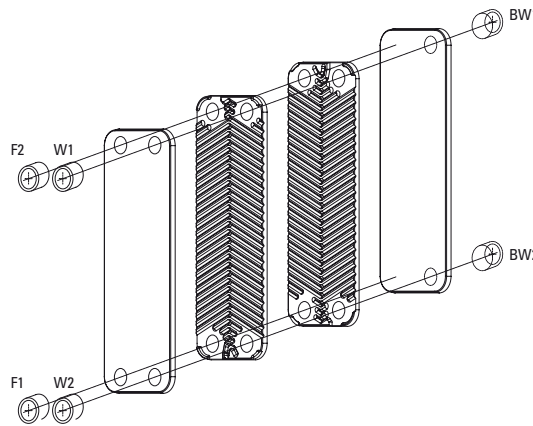

DATI TECNICI - TECHNICAL DATA

VERSIONE / VERSION		TP606	
POTENZA "in condizioni standard di lavoro"	CAPACITY (nominal conditions)	660 kW	
		Circuito - Circuit	
PRESSIONE MASSIMA DI LAVORO	MAXIMUM ALLOVABLE WORKING PRESSURE	50°C F1-F2: .. bar	W1-W2: .. bar
		120°C F1-F2: .. bar	W1-W2: .. bar
		300°C F1-F2: .. bar	W1-W2: .. bar
TEMPERATURA MINIMA DI LAVORO	MIN. DESIGN TEMPERATURE	- 100 °C (-148 °F)	
TEMPERATURA MASSIMA DI LAVORO	MAX DESIGN TEMPERATURE	+ 300 °C (+572 °F)	
NUMERO DI PIASTRE "NP"	NUMBER OF PLATES	min.: 20 max: 250	
NUMERO DI CAMERE	NUMBER PER CHAMBER	Circ./Circuit side F1-F2: (NP/2-1)	Circ./Circuit side W1-W2: (NP/2)
VOLUME PER CAMERA	VOLUME PER CHAMBER	... litri/liters	
PORTATA MASSIMA	TOTAL FLOW RATE m ³ /h	
PESO COMPLESSIVO "P"	TOTAL WEIGHT	P=Np x .. + .. kg	
CONNESSIONE STANDARD CIRCUITO	STANDARD CONNECTION FOR CIRCUIT	F1: DN 80 3" Flexible Joint	F2: DN 100 4" Flexible Joint
		W1: G 4" Cilindrico/ Cylindrical	W2: G 4" Cilindrico/ Cylindrical
CONNESSIONI A RICHIESTA "Da specificare in fase d'ordine"	CONNECTION REQUIRED "To be specified on order"	G 2" 1/2 Cilindrico/ Cylindrical	DN 90 3" 1/2 Flexible Joint
		G 3" Cilindrico/ Cylindrical	G 3" 1/2 Cilindrico/ Cylindrical

MATERIALI - MATERIALS



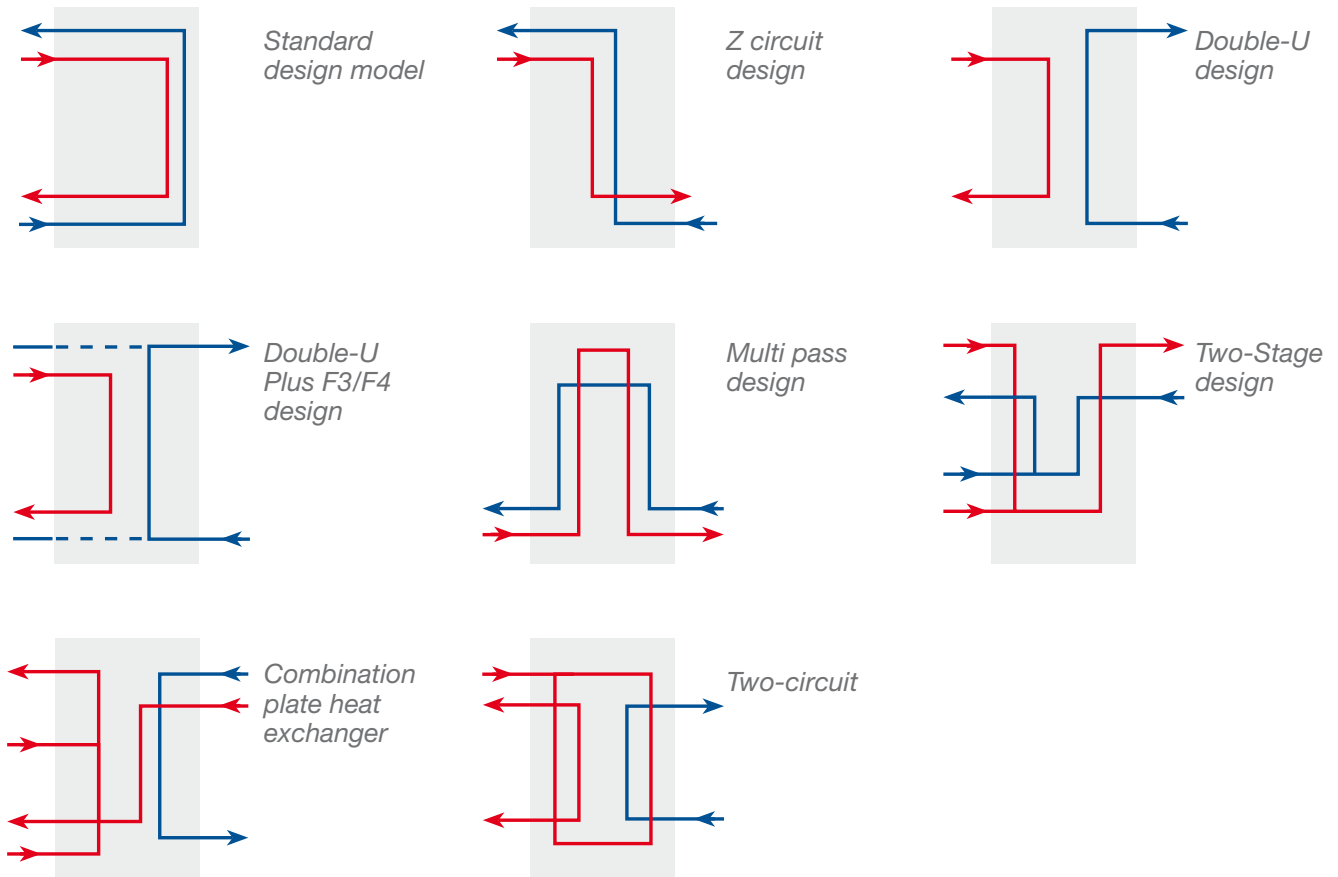













MATERIALE PIASTRA DI SCAMBIO:	PLATE HEAT EXCHANGER MATERIAL:	1.4401 - EN10028/7 "AISI 316L"
MATERIALE CONNESSIONI:	CONNECTIONS MATERIAL:	1.4401 - EN10028/7 "AISI 316L"
MATERIALE BRASANTE:	BRAZING MATERIAL:	RAME PURO / COPPER- Cu -





















COMBINAZIONE - TIPOLOGIA ATTACCHI / CONFIGURATION - CONNECTIONS NO.					MONOCIRCUITO / SINGLE CIRCUIT				CODICE / CODE PART		
4 att.										(Vedi pag. 3 / See page 3)	
	F1	F2		W1	W2					AA	
	F1	F2				BW1	BW2			AB	
	F1	F2		W1			BW2			AC	
	F1	F2			W2	BW1				AD	
		F2		W1		BW1		BF2		AE	
		F2		W1			BW2	BF1		AF	
	F1				W2		BW2	BF1		AG	
	F1				W2	BW1		BF2		AH	
5 att.											
	F1	F2		W1	W2	BW1				BA	
	F1	F2		W1	W2		BW2			BB	
	F1	F2		W1		BW1	BW2			BC	
	F1	F2			W2	BW1	BW2			BD	
6 att.											
	F1	F2		W1	W2	BW1	BW2			CA	
	F1	F2		W1	W2			BF1	BF2	CB	
	F1	F2		W1	W2	BW1			BF2	CC	
	F1	F2		W1	W2		BW2	BF1		CD	
8 att.											
	F1	F2		W1	W2	BW1	BW2	BF1	BF2	DA	



COMBINAZIONE - TIPOLOGIA ATTACCHI / CONFIGURATION - CONNECTIONS NO.					BICIRCUITO / DOUBLE CIRCUIT				CODICE / CODE PART		
6 att.										(Vedi pag. 3 / See page 3)	
	F1	F2	G1	G2			BW1	BW2		MA	
	F1	F2	G1	G2	W1	W2				MB	
7 att.											
	F1	F2	G1	G2	W1		BW1	BW2		NA	
	F1	F2	G1	G2		W2	BW1	BW2		NB	
	F1	F2	G1	G2	W1	W2	BW1			NC	
	F1	F2	G1	G2	W1	W2		BW2		ND	
8 att.											
	F1	F2	G1	G2	W1	W2	BW1	BW2		PA	



CONNESSIONI DISPONIBILI AVAILABLE CONNECTIONS

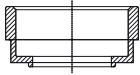

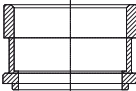
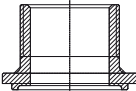
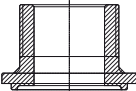
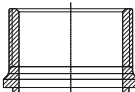
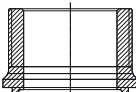
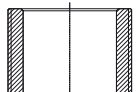
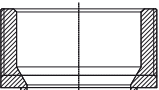
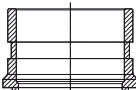
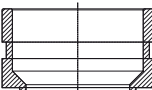
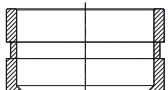
TP09-TP22			
ODS 9.5 e 3/8 INCH codice/code: PR001008 codice/code L9.5 	ODS 12.5 e 1/2 INCH codice/code: PR001014 codice/code L12.5 	ODS 14 codice/code: PR001009 codice/code L14 	ODS 16 e 5/8 INCH codice/code: PR001015 codice/code L16 
ODS 18 codice/code: PR001001 codice/code L918 	ODS 19 e 3/4 INCH codice/code: PR001016 codice/code L19 	ODS 22 e 7/8 INCH codice/code: PR001002 codice/code L22 	1/2" Gas Cil. Femmina/Female codice/code: PR001007 codice/code G2F 
1/2" Gas Con. Maschio/Male codice/code: PR001003 codice/code G2C 	1/2" Gas Cil. Maschio/Male codice/code: PR001004 codice/code G2 	3/4" Gas Con. Maschio/Male codice/code: PR001005 codice/code G3C 	3/4" Gas Cil. Maschio/Male codice/code: PR001006 codice/code G3 
ROTALOCK 3/4" codice/code: PR001013 codice/code R3/4-16UNF 	ROTALOCK 1" codice/code: PR001011 codice/code R31-14UNF 	3/4" Gas Cil. Lungo/Long codice/code: PR001010 codice/code G3SL 	3/4" Gas Cil. Femm. Lungo/Female Long codice/code: PR001012 codice/code G3FL 

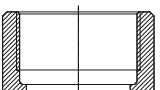
TP12-TP82-TP222				
ODS 22 e 7/8 INCH codice/code: PR002001 codice/code L22A 	ODS 28 e 1 1/8 INCH codice/code: PR00102002 codice/code L28 	ODS 35 e 1 3/8 INCH codice/code: PR002003 codice/code L35 	ROTALOCK 1 1/4 codice/code: PR002018 codice/code R1 1/4-12UNF 	ROTALOCK 1 3/4 codice/code: PR002019 codice/code R1 3/4-12UN 
1" Gas con. Maschio/Male codice/code: PR002004 codice/code G4C 	1" Gas cil. Maschio/Male codice/code: PR002005 codice/code G4 	1 1/4 Gas con. Maschio/Male codice/code: PR002006 codice/code G5C 	1 1/4 Gas cil. Maschio/Male codice/code: PR002007 codice/code G5 	
3/4" Gas cil. Femmina/Female codice/code: PR002015 codice/code G3FA 	1" Gas cil. Femmina/Female codice/code: PR002012 codice/code G4F 	1 1/4 Gas cil. Femmina/Female codice/code: PR002013 codice/code G5F 	1" Gas cil. Maschio/Male corto/short codice/code: PR0020110 codice/code G4SC ODS 22 int. 	1" Gas cil. Maschio/Male lungo/long codice/code: PR002011 codice/code G4SL ODS 22 int. 
Flexible Joint 1 1/4 codice/code: PR002008 codice/code DN32 	Flexible Joint 1 1/2 codice/code: PR002009 codice/code DN40 	Flexible Joint 1 1/4 lungo/long codice/code: PR002016 codice/code DN32SL 	Flexible Joint 1 1/2 lungo/long codice/code: PR002014 codice/code DN40SL 	

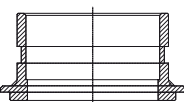
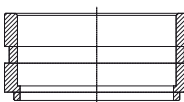
TP222
ODS 42 e 1 5/8 INCH codice/code: PR004001 codice/code L942 
ODS 54 codice/code: PR004002 codice/code L54A 

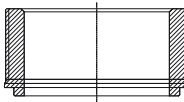
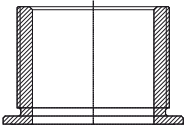
TP202-TP222			
<p>ODS 35 e 1"3/8 INCH codice/code: PR003001 codice/code L35A</p> 	<p>ODS 54 codice/code: PR003002 codice/code L54</p> 	<p>1"1/2 Gas con. Maschio/Male codice/code: PR003003 codice/code G6C</p> 	<p>1"1/2 Gas cil. Maschio/Male codice/code: PR003004 codice/code G6</p> 
<p>2" Gas con. Maschio/Male codice/code: PR003005 codice/code G8C</p> 	<p>2" Gas cil. Maschio/Male codice/code: PR003006 codice/code G8</p> 	<p>2" Gas cil. Maschio Lungo /Male Long codice/code: PR003011 codice/code G8SL</p> 	
<p>2"1/2 Gas cil. Maschio/Male codice/code: PR003009 codice/code G10</p> 	<p>Flexible Joint 2" codice/code: PR003007 codice/code DN50</p> 	<p>Flexible Joint 2"1/2 codice/code: PR003008 codice/code DN65</p> 	<p>Flexible Joint 2"1/2 Øe=76 codice/code: PR003010 codice/code DN65SL</p> 
<p>1"1/2 Gas cil. Femmina/Female codice/code: PR003012 codice/code G6F</p> 	<p>2" Gas cil. Femmina/Female codice/code: PR003013 codice/code G8F</p> 		

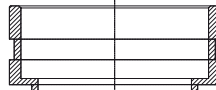
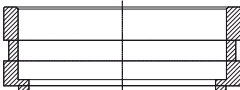
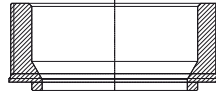
TP404-TP424	
<p>ODS 64 - Flexible Joint 2"1/2 codice/code: PR005001 codice/code L64 - DN65</p> 	<p>ODS 76 - Flexible Joint 3" codice/code: PR005002 codice/code L76 - DN80</p> 
<p>2"1/2 Gas cil. Maschio/Male codice/code: PR005003 codice/code G10A</p> 	<p>3" Gas cil. Maschio/Male codice/code: PR005004 codice/code G12</p> 
<p>2"1/2 Gas cil. Maschio/Male codice/code: PR005005 codice/code G10ASL</p> 	

TP606	
<p>ODS 90 - Flexible Joint 3"1/2 codice/code: PR00.... codice/code L90</p> 	<p>ODS 100 - Flexible Joint 4" codice/code: PR00.... codice/code L100</p> 
<p>3"1/2 Gas cil. Maschio/Male codice/code: PR00.... codice/code G14</p> 	<p>4" Gas cil. Maschio/Male codice/code: PR00.... codice/code G16</p> 

COIBENTAZIONE - ISOLAMENTO INSULATION

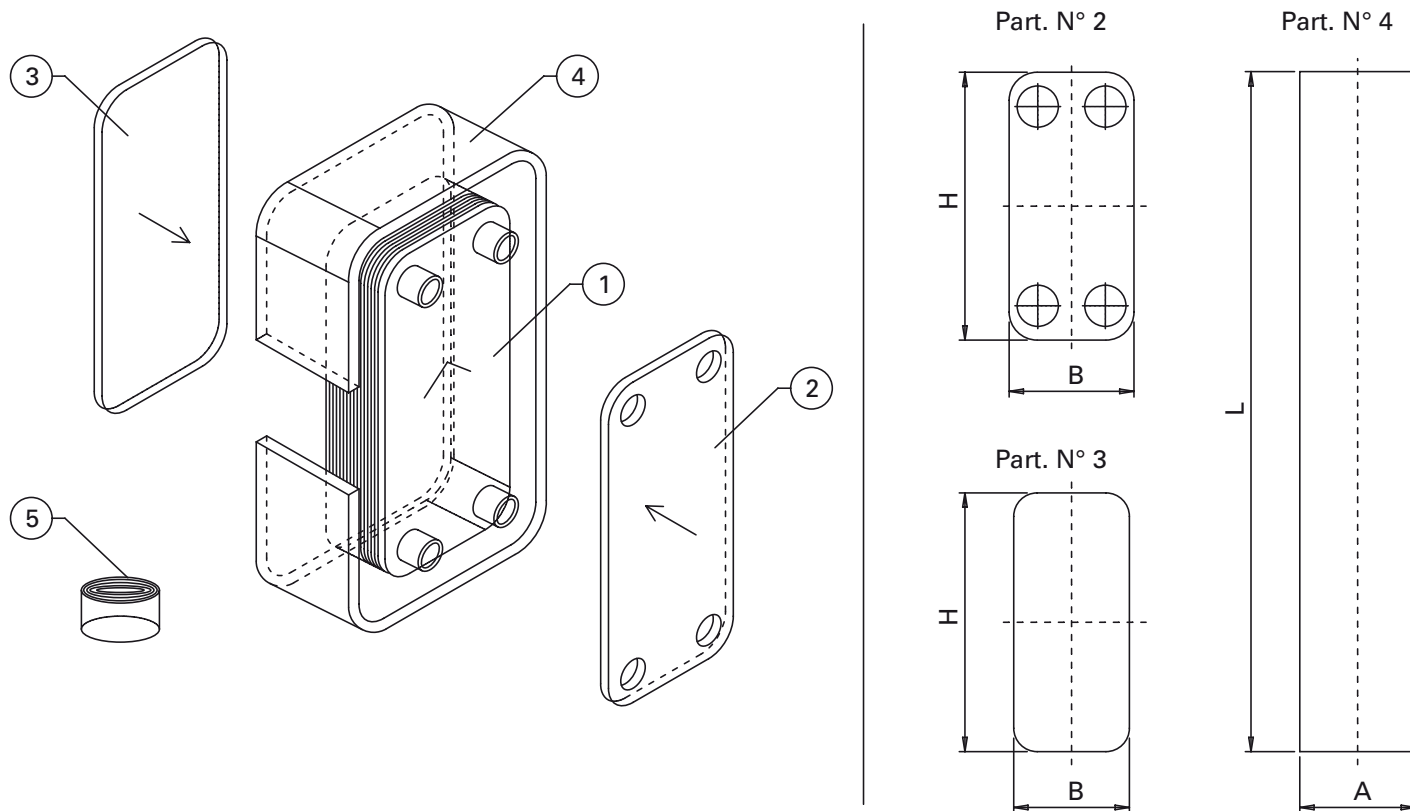

MATERIALE: POLIETILENE RETICOLATO ESPANSO

SPESSORE: 8 mm (a richiesta anche 16 mm)

TEMP. LAVORO: da -50°C a +105°C

MATERIAL: EXPANDED RETICULAR POLYETHYLENE FOAM

THICKNESS: 8 mm (16 mm on request)

MIN. MAX WORKING TEMPERATURE: from -50°C to +105°C

ISOLAMENTO SCAMBIATORI DI CALORE / INSULATION HEAT EXCHANGER

1	SCAMBIATORE DI CALORE SALDOBRASATO	BRAZED PLATE HEATING HEAT EXCHANGER
2	RIVESTIMENTO PARTE FRONTALE CON BIADESIVO	FRONT ADHESIVE PANEL
3	RIVESTIMENTO PARTE INFERIORE CON BIADESIVO	REAR ADHESIVE PANEL
4	RIVESTIMENTO PARTE PERIMETRALE CON BIADESIVO	BORDER ADHESIVE PANEL
5	STRISCIA COPRIGIUNTA (NASTRO DI COPERTURA)	COVER ADHESIVE STRIPE

DIMENSIONI ISOLAMENTO / INSULATION DIMENSIONS						
TIPO SCAMBIATORE HEAT EXCHANGERS TYPE		CODICE COIBENTAZIONE INSULATION CODE	DIMENSIONI / DIMENSIONS (mm)			
MODELLO/ MODEL	N°PIASTRE/PLATES		A	L	B	H
TP09	0-20	PI800901	65	790	90	340
	22-40	PI800902	115			
	42-60	PI800903	165			
	62-80	PI800904	215			
TP22	0-20	PI802201	65	1050	90	470
	22-40	PI802202	115			
	42-60	PI802203	165			
	62-80	PI802204	215			
TP11 - TP12	0-20	PI801201	65	800	135	310
	22-40	PI801202	115			
	42-60	PI801203	165			
	62-80	PI801204	215			
TP71 - TP72	0-20	PI807201	65	1220	135	515
	22-40	PI807202	115			
	42-60	PI807203	165			
	62-80	PI807204	215			
TP82	0-20	PI808201	65	1275	135	540
	22-40	PI808202	115			
	42-60	PI808203	165			
	62-80	PI808204	215			
TP202	0-20	PI820201	65	1485	255	540
	22-40	PI820202	115			
	42-60	PI820203	165			
	62-80	PI820204	215			
	82-100	PI820205	265			
TP222	0-20	PI822201	65	1485	255	540
	22-40	PI822202	115			
	42-60	PI822203	165			
	92-80	PI822204	215			
	82-100	PI822205	265			
TP404	0-20	PI840401	75	2035	315	760
	22-40	PI840402	135			
	42-60	PI840403	195			
	62-80	PI840404	255			
	82-100	PI840405	310			
TP424	0-20	PI842401	75	2035	315	760
	22-40	PI842402	135			
	42-60	PI842403	195			
	62-80	PI842404	255			
	82-100	PI842405	310			

THERMOKEY reserves the right to modify the products contents in this catalogue without previous notice. - THERMOKEY si riserva il diritto di apportare modifiche e migliorie ai prodotti a catalogo in qualsiasi momento e senza preavviso.
THERMOKEY behält sich das Recht vor, die Produkte dieses Katalogs ohne vorherige Ankündigung zu verändern. - THERMOKEY se réserve le droit de modifier les produits de ce catalogue sans avis préalable.



THERMOKEY SPA - VIA DELL'INDUSTRIA 1 - 33050 RIVAROTTA DI TEOR - UDINE - ITALY - TEL. +39 0432772300 FAX +39 0432 779734 - WWW.THERMOKEY.COM - SALES@THERMOKEY.IT

THERMOKEY AUTHORIZED DEALER

