

CONSTANTFLOW Volume Flow Controllers

for constant volume systems
Type EN

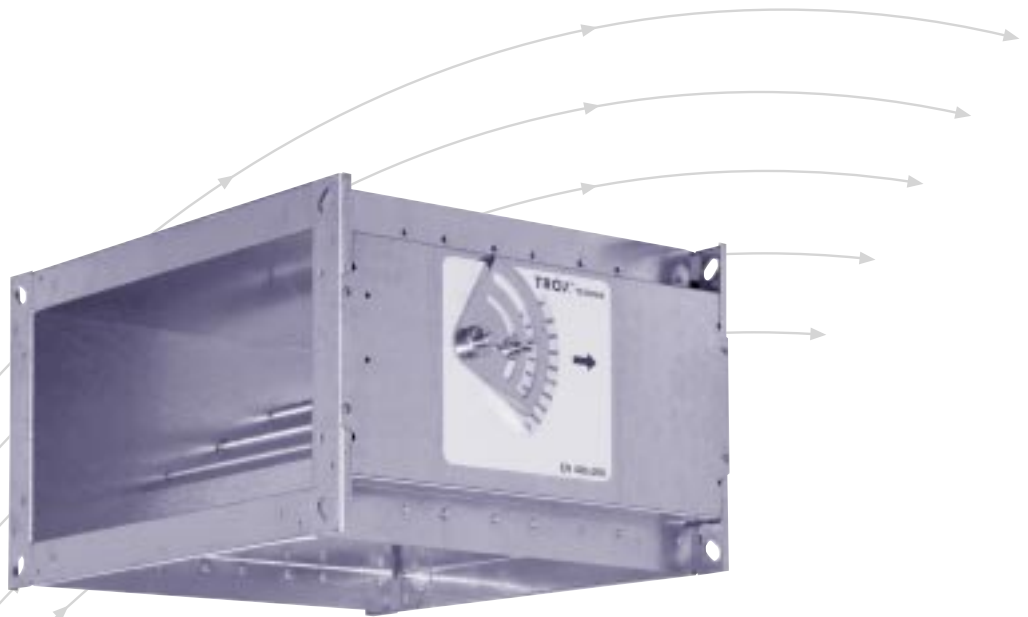

TROX[®] TECHNIK

The art of handling air

Contents · Description

Description _____	2	Nomenclature · Air-regenerated noise _____	8
Application _____	3	Air-regenerated noise _____	9
Construction · Dimensions · Accessories _____	4	Case-radiated noise _____	10
Dimensions _____	5	Order details _____	11
Aerodynamic and acoustic quick selection _____	6		

Type EN volume flow controller



Type END volume flow controller

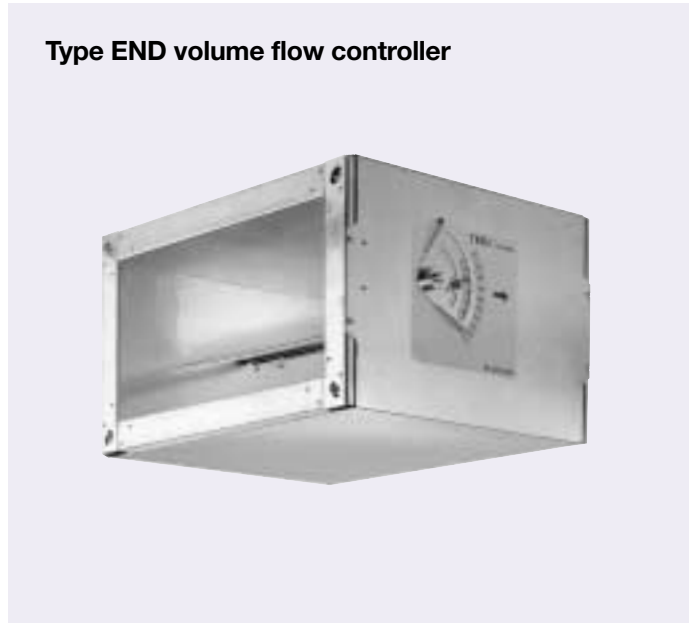

TROX Type EN and END volume flow controllers are mechanical system-powered controllers and were developed for the control of flow rates in constant volume systems. The controllers are suited for both supply air and extract air.

EN: Controller for nominal sizes 200 x 100 to 600 x 600
 END: Controller for nominal sizes 200 x 100 to 600 x 600 with additional acoustic cladding

Each controller is set up to a reference flow rate and has been subjected to an aerodynamic function test.

The required flow rate can be easily set without tools using an external scale. To simplify installation, the controllers can be ordered and fitted by nominal size. The required flow rate can then be easily and accurately set during commissioning.

The EN controllers are also available with additional acoustic cladding to reduce case-radiated noise (END). For more stringent noise requirements the TX silencer can be used.

The controller operates without an external power supply. A control damper blade, shaft mounted supported on bearings, is adjusted by the aerodynamic forces such that the preset flow rate is held constant over the entire differential pressure range. Aerodynamic forces from air flow create a closing force on the damper blade. A self inflating bellows amplifies this force, acting

simultaneously as an oscillation damper. This closing force is counteracted by a leaf spring that unrolls over a cam plate. The cam plate is designed such that as the pressure differential changes, the damper blade adjusts to keep a constant flow rate within close tolerances.

Further, current information on application and selection can be found in the "Technical Documentation" download area of our website.

Also available on the Internet is the "Air terminal units" on-line programme for the design and selection of our units.

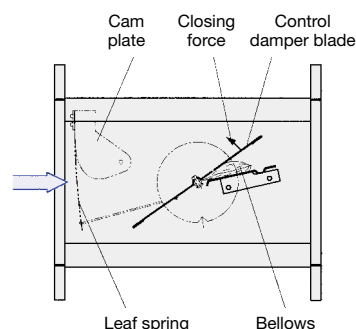

Inexpensive commissioning

By a simple step and without need for preliminary measurements, the required flow rate value can be set using the pointer against the externally mounted scale of the Type EN or END . The advantage over conventional balancing dampers is that there is no need for repeated measurement and readjustment by a qualified commissioning engineer.

Should the system pressure change, e.g. by opening or closing of duct sections, the flow rates in the entire system will alter if balancing dampers are used; however, this is not the case if the Type EN and ENS volume flow controllers are used.

The controller reacts immediately and adjusts the damper blade position directly, so that the flow rate set is kept constant over the entire differential pressure range.

The Type EN controllers can be fitted with an electric actuator for setpoint value readjustment.

Simplified installation

The Type EN and END volume flow controllers are fitted with flanges on both ends. This ensures very low leakage at the joint.

Acoustic requirements

Depending on requirements, a TX silencer may be supplied to reduce the air-regenerated noise. (installed by others).

Type EN volume flow controller with actuator

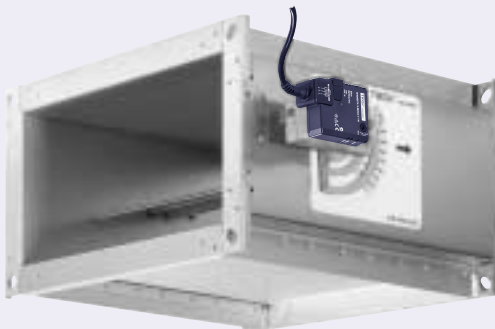

**Type EN volume flow controller, $H \geq 400$ mm
(Two controllers used)**



TX silencer

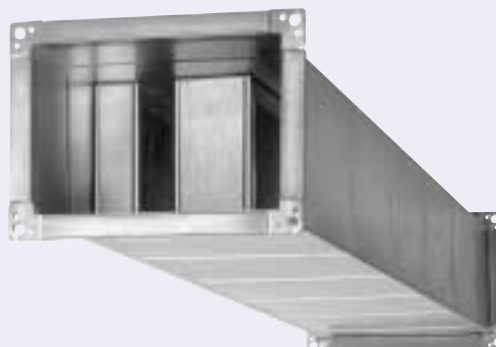

Construction · Dimensions · Accessories

Characteristics

- Mechanical system-powered, without external power supply
- Suitable for supply and extract air
- Correct operation, even under unfavourable upstream and downstream conditions (straight length required upstream 1.5 B, downstream 0.5 B)
- Close tolerances on flow rate
- Flow rate setting using pointer on external scale, scale accuracy approximately $\pm 4\%$
- Flow rate range 4 : 1
- Damper blade shaft supported in bearings
- Bellows also acts as an oscillation damper
- Differential pressure range 50 to 1000 Pa
- Independent of orientation
- Damper blade mechanisms maintenance-free
- Operating temperature range 10 to 50 °C

Constructional features

- Rectangular form, rigid frame
- Flanged at both ends, suitable for fitting System 30 connecting sections

Casing

- Casing and damper blade made of galvanised sheet steel
- Stainless steel leaf spring
- Polyurethane bellows
- Plain bearings with PTFE coating

Additional acoustic cladding

- Outer cover in galvanised sheet steel
- Sound-absorbent lining
- Structure-borne noise isolation
- Cannot be retrofitted

Actuators

- For setpoint readjustment
- 24 VAC or 230 VAC power
- Factory-fitted
- Small footprint thanks to compact construction

TX silencer

- Suitable for EN/END controllers
- Casing in galvanised sheet steel
- Mineral wool lining conforming to DIN 4102, fire rating class A2, with RAL quality mark RAL-GZ 388, biodegradable as defined by TRGS 905 as well as EU directive 97/69/EC
- Mineral wool faced with glass-fibre fabric providing protection against erosion by air flow up to a maximum air velocity of 20 m/s, inert to fungal and bacterial growth

Air heater

- Suitable for EN/END controllers
- See leaflet 5/20/EN/... for dimensions and technical data

EN · END

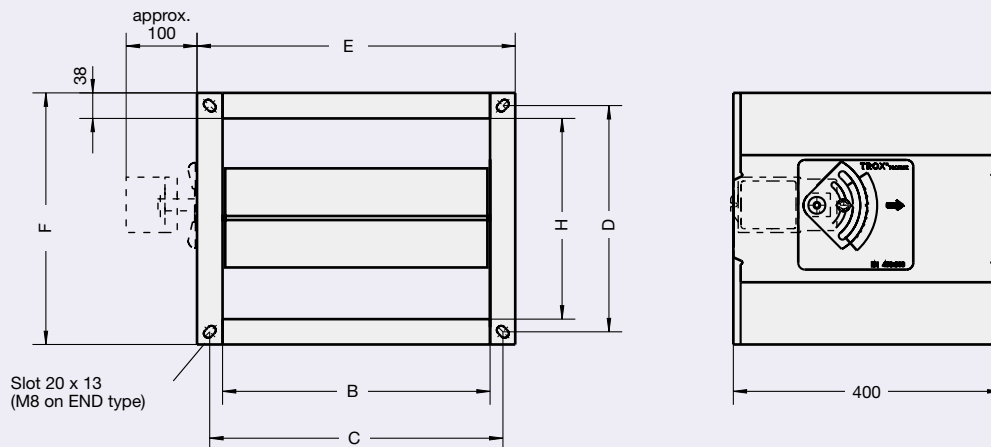

TX

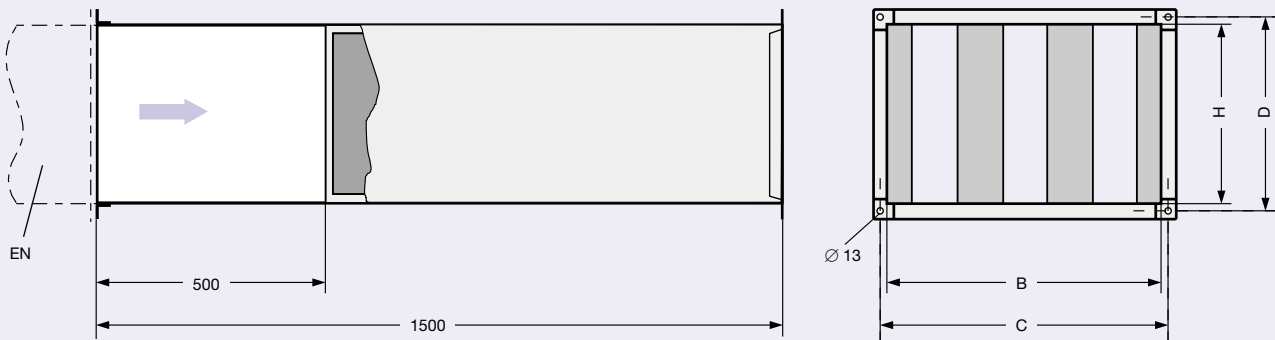

Connection of rectangular duct

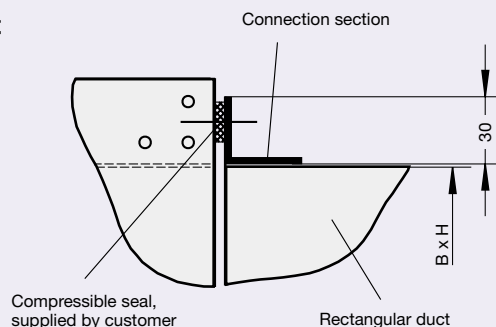

Dimensions

B x H		Dimensions in mm						Weight in kg		
		C	D	EN		END		EN	END	TX
				E	F	E	F			
200	100	234	134	276	176	280	180	5	8	10
300		334	134	376	176	380	180	6	10	12
300	150	334	184	376	226	380	230	6.5	11	15
300	200	334	234	376	276	380	280	7	12	20
400		434	234	476	276	480	280	9	15	25
500		534	234	576	276	580	280	11	17	29
600		634	234	676	276	680	280	13	20	34
400	250	434	284	476	326	480	330	10	17	27
500		534	284	576	326	580	330	12	18	30
600		634	284	676	326	680	330	14	22	36
400	300	434	334	476	376	480	380	12	18	29
500		534	334	576	376	580	380	13	19	34
600		634	334	676	376	680	380	15	22	40
400	400	434	434	476	476	480	480	18	26	39
500		534	434	576	476	580	480	17.5	25.5	42
600		634	434	676	476	680	480	18	26	45
500	500	534	534	576	576	580	580	18.5	28	45
600		634	534	676	576	680	580	19	29	50
600	600	634	634	676	676	680	680	20	30	55

Aerodynamic and Acoustic Quick Selection

System attenuation in dB/Oct. acc. to VDI 2081 (values incorporated into the quick selection table)								
f_m in Hz	63	125	250	500	1000	2000	4000	8000
Duct bend attenuation	0	0	1	2	3	3	3	3
Room attenuation	5	5	5	5	5	5	5	5
End reflection	10	5	2	0	0	0	0	0

Correction for distribution into the duct system (values incorporated into the quick selection table)									
\dot{V}	l/s	140	280	555	1110	1670	2220	2780	3360
	m ³ /h	504	1008	2016	3996	6012	7992	10008	12096
dB per octave		0	3	6	9	11	12	13	14

Quick selection of sound pressure level in dB(A)																		
B x H	\dot{V}		$\Delta \dot{V}$	$\Delta p_{g \min}$ in Pa		$\Delta p_g = 100 \text{ Pa}$				$\Delta p_g = 200 \text{ Pa}$				$\Delta p_g = 500 \text{ Pa}$				
						Air-regenerated noise		Case-radiated noise ²⁾		Air-regenerated noise		Case-radiated noise ²⁾		Air-regenerated noise		Case-radiated noise ²⁾		
						L_{pA}	L_{pA1}	L_{pA2}	L_{pA3}	L_{pA}	L_{pA1}	L_{pA2}	L_{pA3}	L_{pA}	L_{pA1}	L_{pA2}	L_{pA3}	
						without silencer	with TX silencer	without additional acoustic cladding	with additional acoustic cladding	without silencer	with TX silencer	without additional acoustic cladding	with additional acoustic cladding	without silencer	with TX silencer	without additional acoustic cladding	with additional acoustic cladding	
mm	l/s	m ³ /h	$\pm \%$	EN	TX ¹⁾													
200 100	40	144	13	50	10	32	18	22	<	41	22	29	21	47	28	35	26	
	80	288	9	50	30	38	27	30	24	46	32	36	29	52	36	41	34	
	120	432	6	50	65	42	32	34	29	49	38	40	34	56	43	46	39	
	160	576	5	50	110	43	35	37	32	51	41	44	38	58	47	49	42	
	300	65	234	13	50	10	35	20	25	17	43	25	32	24	50	30	38	29
	130	468	9	50	30	41	29	33	26	49	34	39	32	55	39	44	36	
300 150	195	702	6	50	70	43	34	37	32	50	39	43	37	57	44	48	41	
	260	936	5	50	120	44	36	40	35	52	42	46	40	58	47	51	44	
	300 150	105	378	13	50	10	38	22	27	19	46	28	34	25	52	33	40	30
	210	756	9	50	30	42	29	34	27	49	35	40	32	56	40	46	37	
	315	1134	6	50	65	44	34	39	32	51	40	45	38	57	44	50	42	
	420	1512	5	50	110	45	37	42	36	52	42	48	41	58	47	53	45	
300 200	130	468	13	50	10	42	21	29	19	51	30	37	27	57	37	43	33	
	260	936	9	50	30	43	26	33	24	52	34	41	32	59	41	48	39	
	390	1404	6	50	65	44	30	36	28	52	38	44	36	60	45	51	42	
	520	1872	5	50	110	44	32	39	31	53	41	46	39	60	47	53	45	
	400	210	756	13	50	10	39	20	29	19	48	28	36	26	55	35	43	33
	420	1512	9	50	30	40	24	33	25	49	33	41	32	56	39	47	39	
400	630	2268	6	50	75	41	28	36	28	49	36	44	36	57	43	50	43	
	840	3024	5	50	110	42	31	39	32	50	39	46	40	57	45	52	45	
	500	230	828	13	50	10	37	18	26	16	46	26	34	25	53	33	41	31
	460	1656	9	50	30	38	23	31	23	47	31	39	31	54	37	45	37	
	690	2484	6	50	65	38	26	34	27	47	35	42	35	54	41	48	41	
	920	3312	5	50	110	39	29	37	30	48	37	44	38	55	43	50	44	
600	255	918	13	50	10	35	17	25	16	44	25	33	24	50	32	39	30	
	510	1836	9	50	25	36	22	30	22	44	30	37	30	51	36	44	36	
	765	2754	6	50	50	37	25	33	26	45	33	41	34	52	40	47	40	
	1020	3672	5	50	110	37	28	35	30	46	36	43	37	53	42	50	44	
	400 250	220	792	13	50	5	41	20	29	18	49	29	36	26	56	35	43	33
	440	1584	9	50	25	41	25	33	24	51	33	41	32	57	39	47	38	
500	660	2376	6	50	50	42	29	36	27	51	37	43	35	58	43	50	41	
	880	3168	5	50	110	43	31	38	30	52	39	46	38	58	46	52	44	
	300	1080	13	50	10	38	19	27	17	47	27	36	26	54	34	42	32	
	600	2160	9	50	30	39	23	32	23	48	32	40	31	55	38	47	38	
	900	3240	6	50	65	40	27	35	27	49	35	43	35	56	42	49	41	
	1200	4320	5	50	110	41	30	37	31	49	38	45	38	56	44	51	44	
600	320	1152	13	50	5	37	17	26	16	45	25	34	24	52	32	40	31	
	640	2304	9	50	25	37	22	30	22	46	30	38	30	53	36	45	36	
	960	3456	6	50	50	38	26	33	26	47	34	41	34	54	40	48	40	
	1280	4608	5	50	110	38	28	36	29	48	37	45	38	55	43	51	44	

1) also to be taken into consideration

< indicates values below 15

2) 4 dB/octave ceiling reduction and 5 dB/octave room attenuation have been allowed for in the calculation of case-radiated noise
Acoustic data for differential pressure up to 1000 Pa, see on-line design programme "Air terminal units".

Aerodynamic and Acoustic Quick Selection

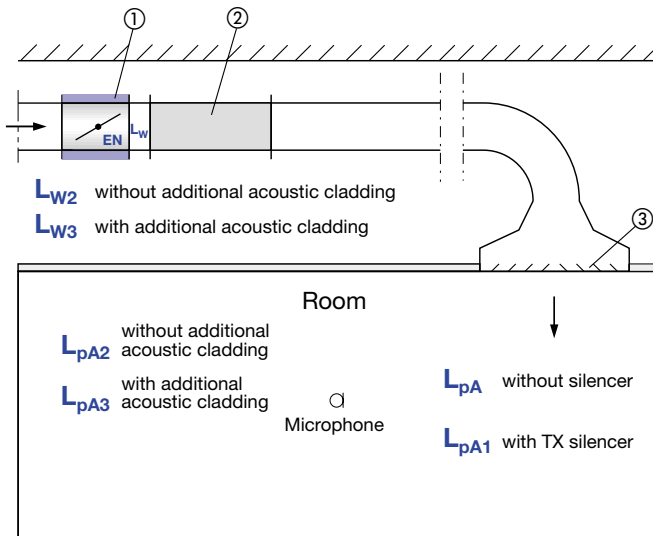

- ① Additional acoustic cladding
- ② TX silencer
- ③ End reflection based on diffuser

Nomenclature, see page 8

Quick selection of sound pressure level in dB(A)

B x H	V̇		ΔV̇	Δp _{g min} in Pa		Δp _g = 100 Pa				Δp _g = 200 Pa				Δp _g = 500 Pa									
						Air-regenerated noise		Case-radiated noise ²⁾		Air-regenerated noise		Case-radiated noise ²⁾		Air-regenerated noise		Case-radiated noise ²⁾							
						L _{pA}	L _{pA1}	L _{pA2}	L _{pA3}	L _{pA}	L _{pA1}	L _{pA2}	L _{pA3}	L _{pA}	L _{pA1}	L _{pA2}	L _{pA3}						
						without silencer	with TX silencer	without additional acoustic cladding	with additional acoustic cladding	without silencer	with TX silencer	without additional acoustic cladding	with additional acoustic cladding	without silencer	with TX silencer	without additional acoustic cladding	with additional acoustic cladding						
400 x 300	315	1134	13	50	10	43	22	32	21	51	30	40	29	58	37	46	36						
						630	2268	9	50	30	44	27	37	27	52	35	44	35	59	41	50	41	
						945	3402	6	50	70	44	31	39	31	53	39	47	38	59	45	53	44	
	500	1260	4536	5	50	110	44	33	41	34	53	41	49	41	60	47	55	47					
							375	1350	13	50	10	40	20	30	20	48	28	38	28	55	34	44	34
							750	2700	9	50	30	41	25	35	26	49	33	42	33	56	39	49	40
	600	1125	4050	6	50	65	42	29	37	29	50	36	45	37	57	43	51	43					
							1500	5400	5	50	110	42	31	40	32	50	39	47	40	57	45	53	46
							420	1512	13	50	10	38	18	28	18	47	27	36	26	53	33	42	32
	400 x 400	840	3024	9	50	25	39	23	32	23	47	31	40	31	54	37	46	37					
							1260	4536	6	50	60	40	27	35	27	48	35	43	35	55	41	49	41
							1680	6048	5	50	100	40	29	37	30	49	37	45	38	55	44	51	44
500	420	1512	13	50	10	45	24	35	24	53	32	42	32	60	39	49	38						
						840	3024	9	50	30	46	29	39	30	54	37	47	37	60	43	53	43	
						1260	4536	6	50	70	46	33	42	33	55	41	49	40	61	47	56	46	
600	1680	6048	5	50	125	47	35	44	36	55	43	52	43	62	49	57	49						
						460	1656	13	50	10	42	22	32	22	51	30	40	30	57	36	46	36	
						920	3312	9	50	30	43	26	37	27	52	34	45	35	58	40	51	41	
500 x 500	1380	4968	6	50	65	44	30	39	30	52	38	47	38	59	44	53	44						
						1840	6624	5	50	110	44	33	42	33	53	40	49	41	59	46	55	47	
						510	1836	13	50	5	41	19	31	21	49	28	39	28	55	34	45	34	
600	1020	3672	9	50	20	41	24	35	26	49	32	43	33	56	38	49	39						
						1530	5508	6	50	45	42	28	38	29	50	36	46	36	57	42	52	42	
						2040	7344	5	50	110	42	31	40	32	50	39	47	39	57	45	53	45	
600 x 600	600	2160	13	50	10	44	24	36	25	52	31	43	33	59	38	49	39						
						1200	4320	9	50	30	46	28	40	30	54	36	48	38	60	42	53	44	
						1800	6480	6	50	65	46	32	43	34	54	40	51	41	60	46	56	47	
600	2400	8640	5	50	110	46	35	45	36	55	42	53	44	61	48	58	49						
						640	2304	13	50	5	42	21	34	23	50	29	42	31	57	35	47	36	
						1280	4608	9	50	30	43	26	38	28	51	34	46	36	58	40	52	42	
600	1920	6912	6	50	45	44	30	41	31	52	38	48	39	58	44	54	45						
						2560	9216	5	50	80	44	32	43	34	52	40	50	42	59	46	56	47	
						840	3024	13	50	5	43	23	35	25	52	31	44	33	58	37	49	39	
600	1680	6048	9	50	25	45	28	41	31	53	35	48	38	59	41	53	44						
						2520	9072	6	50	55	46	32	43	34	54	40	50	41	60	46	56	47	
						3360	12096	5	50	95	46	34	45	36	54	42	52	43	61	48	58	49	

1) also to be taken into consideration

2) 4 dB/octave ceiling reduction and 5 dB/octave room attenuation have been allowed for in the calculation of case-radiated noise
Acoustic data for differential pressure up to 1000 Pa, see on-line design programme "Air terminal units".

Nomenclature · Air-regenerated Noise

Nomenclature

f_m	in Hz: Octave band centre frequency
L_W	in dB: Sound power level of air-regenerated noise in the room (low pressure) side ducting
L_{W2}	in dB: Sound power level of case-radiated noise
L_{W3}	in dB: Sound power level of case-radiated noise with additional acoustic cladding
L_{pA}	in dB: A-weighted sound pressure level of air-regenerated noise in the room, system attenuation taken into account
L_{pA1}	in dB: A-weighted sound pressure level of air-regenerated noise in the room with TX silencer, system attenuation taken into account
L_{pA2}	in dB: A-weighted sound pressure level of case-radiated noise in the room, system attenuation taken into account
L_{pA3}	in dB: A-weighted sound pressure level of case-radiated noise in the room with additional acoustic cladding, system attenuation taken into account

ΔL_W	in dB: Correction value for case-radiated noise without additional acoustic cladding
ΔL_{W1}	in dB: Correction value for case-radiated noise with additional acoustic cladding
\dot{V}	in m ³ /h or l/s: Flow rate
$\Delta \dot{V}$	in \pm %: Flow rate tolerance from setpoint value
Δp_g	in Pa: Total pressure differential
$\Delta p_{g\min}$	in Pa: Minimum total pressure differential

All sound power levels are based on 1 pW, all sound pressure levels on 20 μ Pa.

All noise levels measured in a reverberation chamber. The sound power data was determined and corrected according to DIN EN ISO 5135, February 1999.

B x H		V		Air-regenerated noise																											
				$\Delta p_g = 100$ Pa								$\Delta p_g = 200$ Pa								$\Delta p_g = 500$ Pa											
				L_W in dB								L_W in dB								L_W in dB											
				f_m in Hz								f_m in Hz								f_m in Hz											
mm	l/s	m ³ /h	63	125	250	500	1000	2000	4000	8000	63	125	250	500	1000	2000	4000	8000	63	125	250	500	1000	2000	4000	8000					
200	100	40	144	42	41	31	31	34	36	30	22	46	45	37	37	40	45	41	34	49	49	42	42	45	51	48	43				
		80	288	51	51	39	38	40	41	37	30	55	55	45	44	46	49	47	41	58	58	50	49	51	55	54	50				
		120	432	56	56	44	42	44	44	40	34	60	61	50	48	50	52	50	46	63	64	55	53	54	58	58	55				
		160	576	60	60	47	44	46	45	43	37	64	65	54	51	52	54	53	49	67	68	58	56	57	60	61	58				
300		65	234	43	43	34	35	37	39	32	24	47	48	41	42	43	47	42	36	50	51	45	47	48	54	50	45				
		130	468	52	53	43	42	44	44	39	31	56	57	49	48	50	52	49	43	59	60	54	53	54	58	56	52				
		195	702	57	59	48	46	47	46	42	35	61	63	54	52	53	54	52	47	64	66	58	57	58	61	60	56				
		260	936	61	63	51	48	50	48	45	38	65	67	57	55	56	56	55	50	68	70	62	60	63	63	62	59				
300	150	105	378	44	45	38	39	41	42	34	25	48	50	44	46	47	50	44	37	51	53	49	51	51	56	52	46				
		210	756	53	55	46	46	47	46	40	32	57	59	52	52	53	54	50	44	59	63	57	57	57	61	58	53				
		315	1134	58	61	51	50	51	49	44	36	62	65	57	56	57	57	54	48	65	68	62	61	61	63	62	57				
		420	1512	62	65	54	52	53	51	47	39	66	69	60	59	59	59	57	51	68	72	65	64	64	65	64	60				
300	200	130	468	49	37	37	41	46	45	39	34	55	45	45	48	53	54	50	46	60	51	51	53	58	61	58	55				
		260	936	59	46	44	46	49	49	44	38	65	54	52	53	56	58	54	50	70	60	58	58	62	65	63	59				
		390	1404	64	51	49	49	51	51	46	40	71	59	56	56	58	60	57	52	75	65	62	61	64	68	65	61				
		520	1872	68	54	52	51	52	53	48	42	75	62	59	58	60	62	59	54	79	68	65	63	65	69	67	63				
400		210	756	48	42	37	41	45	44	39	33	54	50	44	47	52	53	50	45	59	56	50	52	58	60	58	54				
		420	1512	58	50	44	46	48	48	44	37	64	58	51	52	55	57	54	49	69	64	57	57	61	64	63	58				
		630	2268	63	55	48	49	50	50	46	40	70	63	56	55	57	59	57	52	74	70	61	60	63	67	65	61				
		840	3024	67	59	51	51	52	52	48	41	74	67	59	58	59	61	59	53	78	73	64	63	64	68	67	62				
500		230	828	43	42	33	38	43	42	37	31	49	50	41	45	50	51	48	43	54	56	47	50	56	58	56	52				
		460	1656	53	51	40	44	46	45	42	35	59	59	48	50	53	55	53	47	64	65	54	55	59	62	61	56				
		690	2484	59	56	45	47	48	48	44	38	65	64	52	53	55	57	55	49	70	70	58	58	61	64	63	58				
		920	3312	63	59	48	49	50	49	46	39	69	67	55	55	57	59	57	51	74	73	61	60	62	66	65	60				
600		255	918	40	43	31	37	42	40	36	30	46	51	38	43	49	49	47	41	51	57	44	48	54	56	55	50				
		510	1836	49	51	38	42	45	44	40	34	56	59	45	48	52	53	51	45	60	65	51	53	57	60	59	54				
		765	2754	55	56	42	45	47	46	43	36	61	64	50	51	54	55	54	48	66	70	55	56	59	62	62	57				
		1020	3672	59	60	45	47	48	48	45	38	65	68	53	54	55	57	56	49	70	74	58	59	61	64	64	58				
400	250	220	792	47	40	38	43	47	46	40	34	53	48	46	50	54	55	50	45	58	54	51	55	60	62	59	54				
		440	1584	57	48	45	48	50	49	44	38	63	56	53	55	58	59	55	49	68	62	58	60	63	66	63	58				
		660	2376	62	53	49	51	52	52	46	40	68	61	57	58	59	61	57	52	73	67	63	63	65	68	66	61				
		880	3168	66	57	52	53	54	53	48	42	73	65	60	60	61	63	59	53	77	71	66	65	66	70	67	62				
500		300	1080	45	42	37	42	46	44	39	33	51	51	44	49	53	54	50	45	56	57	50	54	59	61	58	53				
		600	2160	55	51	44	47	49	48	43	37	61	59	52	54	57	58	54	49	66	65	57	59	62	65	63	57				
		900	3240	61	56	48	50	51	51	46	39	67	64	56	57	59	60	57	51	72	70	61	62	64	67	65	60				
		1200	4320	65	60	51	52	53	52	48	41	71	68	59	59	60	62	59	52	76	74	64	64	65	69	67	61				
600		320	1152	41	43	34	40	45	43	38	31	47	51	42	47	52	52	48	43	52	57	47	52	57	59	57	52				
		640	2304	51	51	41	45	48	46	42	35	57	59	49	52	55	56	53	47	62	65	54	57	60	63	61	56				
		960	3456	57	56	45	48	50	49	44	37	63	64	53	55	57	58	55	49	68	70	59	60	62	65	64	58				
		1280	4608	61	60	48	50	51	50	46	39	69	69	57	58	59	60	58	51	73	75	63	63	64	67	66	60				

Acoustic data for differential pressure up to 1000 Pa, see on-line design programme "Air terminal units".

Air-regenerated Noise

Example

Given: $\dot{V}_{max} = 420 \text{ l/s}$ or $1512 \text{ m}^3/\text{h}$
 $\Delta p_g = 100 \text{ Pa}$
 Required sound pressure level in the room 45 dB(A)
 For further assumptions, see calculation procedure

Calculation procedure

Quick selection:

EN/400 x 200

Air-regenerated noise

$L_{pA} = 40 \text{ dB(A)}$

Case-radiated noise

$L_{pA2} = 33 \text{ dB(A)}$

Sound pressure level in the room = 41 dB(A)

(after logarithmic addition, as the unit is in the false ceiling of the room, see drawing page 7)

Air-regenerated noise calculation procedure

f_m	63	125	250	500	1000	2000	4000	8000
L_w (page 8)	58	50	44	46	48	48	44	37
Distribution	5	5	5	5	5	5	5	5
Duct bend	1	2	3	3	3	3	3	3
End reflection	12	7	3	1	0	0	0	0
Sound power level to room	40	36	33	37	40	40	36	29
Room attenuation	6	6	5	5	4	4	4	4
A-weighting	-26	-16	-9	-3	0	1	1	-1
Corrected level	8	14	19	29	36	37	33	24

Sound pressure level of the air-regenerated noise
 L_{pA} approx. **41 dB(A)**

B x H		\dot{V}		Air-regenerated noise																							
				$\Delta p_g = 100 \text{ Pa}$								$\Delta p_g = 200 \text{ Pa}$								$\Delta p_g = 500 \text{ Pa}$							
				L_w in dB								L_w in dB								L_w in dB							
				f_m in Hz								f_m in Hz								f_m in Hz							
mm	l/s	m^3/h	63	125	250	500	1000	2000	4000	8000	63	125	250	500	1000	2000	4000	8000	63	125	250	500	1000	2000	4000	8000	
400	300	315	1134	50	42	42	47	50	49	42	36	57	50	50	54	57	58	53	47	61	56	56	59	63	65	61	56
		630	2268	60	50	50	52	54	53	46	40	66	58	57	59	61	62	57	51	71	64	63	64	66	69	65	60
		945	3402	66	55	54	55	56	55	49	42	72	63	61	62	63	64	60	54	77	69	67	67	68	71	68	63
		1260	4536	70	59	57	57	56	51	44	76	67	64	64	64	66	61	55	81	73	70	69	69	73	70	64	
500	500	375	1350	47	43	40	45	49	47	41	34	53	51	47	52	56	56	51	46	58	57	53	57	61	63	60	55
		750	2700	57	52	47	50	52	51	45	38	63	60	55	57	59	60	56	50	68	66	60	62	65	67	64	59
		1125	4050	62	57	51	53	54	53	47	40	69	65	59	60	61	62	58	52	73	71	64	65	67	69	67	61
		1500	5400	66	60	54	56	55	55	49	42	73	68	62	62	64	60	54	77	74	67	67	68	71	68	63	
600	600	420	1512	44	44	37	44	47	45	39	32	50	52	45	50	55	55	50	44	55	58	51	55	60	62	58	53
		840	3024	53	52	45	49	51	49	44	36	60	60	52	55	58	58	55	48	64	66	58	60	63	65	63	57
		1260	4536	59	57	49	52	53	51	46	39	65	65	56	58	60	61	57	50	70	71	62	63	65	68	65	59
		1680	6048	63	61	52	54	54	53	48	40	69	69	59	61	61	62	59	52	74	75	65	66	67	69	67	61
400	400	420	1512	52	42	46	52	54	52	44	37	58	50	54	58	61	62	55	49	63	56	60	63	67	69	63	58
		840	3024	62	50	54	57	57	56	48	41	68	58	61	63	65	65	59	53	73	64	67	68	70	72	67	62
		1260	4536	68	55	58	60	59	58	51	44	74	63	65	66	66	68	61	55	79	69	71	71	72	75	70	64
		1680	6048	72	59	61	62	61	60	52	45	78	67	68	68	68	69	63	57	83	73	74	73	73	76	72	66
500	500	460	1656	47	42	43	49	52	50	42	35	54	50	51	56	59	59	53	47	58	56	56	61	65	66	61	56
		920	3312	57	51	50	54	55	54	46	39	63	59	58	61	63	63	57	51	68	65	64	66	68	70	65	60
		1380	4968	63	56	54	57	57	56	49	41	69	64	62	64	65	65	60	53	74	70	68	69	70	72	68	62
		1840	6624	67	59	57	59	59	58	51	43	73	67	65	66	66	67	61	55	78	73	71	71	71	74	70	64
600	600	510	1836	44	42	41	48	51	48	41	33	50	51	48	54	58	57	52	45	55	57	54	59	63	65	60	54
		1020	3672	54	51	48	53	54	52	45	37	60	59	55	59	61	61	56	49	65	65	61	64	67	68	64	58
		1530	5508	59	56	52	56	56	54	47	40	66	64	59	62	63	64	58	52	70	70	65	67	68	71	67	60
		2040	7344	63	60	55	58	57	56	49	41	70	68	62	64	64	65	60	53	74	74	68	69	70	72	68	62
500	500	600	2160	49	42	47	53	55	53	44	36	56	50	54	60	62	62	55	48	60	57	60	65	68	69	63	57
		1200	4320	59	51	54	58	59	57	48	40	65	59	61	65	66	66	59	52	70	65	67	70	71	73	67	61
		1800	6480	65	56	58	61	60	59	51	43	71	64	66	68	68	68	61	55	76	70	71	73	73	75	70	64
		2400	8640	69	60	61	63	62	60	52	44	75	68	69	70	69	70	63	56	80	74	74	75	74	77	71	65
600	600	640	2304	45	42	44	51	54	51	42	35	52	51	51	58	61	60	53	46	56	57	57	63	66	67	61	55
		1280	4608	55	51	51	56	57	55	46	39	61	59	59	63	64	64	57	50	66	65	64	68	70	71	66	59
		1920	6912	61	56	55	59	59	57	49	41	67	64	63	66	66	66	60	53	72	70	68	71	71	73	68	62
		2560	9216	65	60	58	61	60	58	51	43	71	68	66	68	67	68	62	54	76	74	71	73	73	75	70	63
600	600	840	3024	48	44	47	54	56	53	44	36	54	52	55	61	64	63	55	48	59	58	61	66	69	70	63	57
		1680	6048	58	52	54	60	60	57	48	40	64	60	62	66	67	67	59	52	69	66	68	71	72	74	67	61
		2520	9072	63	57	59	63	62	59	51	42	70	65	66	69	69	69	62	54	74	71	72	74	74	76	70	63
		3360	12096	67	61	62	65	63	61	53	44	74	69	69	71	70	70	63	56	78	75	75	76	76	78	72	65

Acoustic data for differential pressure up to 1000 Pa, see on-line design programme "Air terminal units".

Case-radiated Noise

Example

Given: $\dot{V}_{\max} = 420 \text{ l/s}$ or $1512 \text{ m}^3/\text{h}$
 $\Delta p_g = 100 \text{ Pa}$
 Required sound pressure level in the room 45 dB(A)
 For further assumptions, see calculation procedure

Calculation procedure

Quick selection:
 EN/400 x 200
 Air-regenerated noise
 $L_{pA} = 40 \text{ dB(A)}$
 Case-radiated noise
 $L_{pA2} = 33 \text{ dB(A)}$
 Sound pressure level in the room = 41 dB(A)
 (after logarithmic addition, as the unit is in the false ceiling of the room, see drawing page 7)

Case-radiated noise calculation procedure

f_m	63	125	250	500	1000	2000	4000	8000
L_W (page 8)	58	50	44	46	48	48	44	37
ΔL_W	4	5	4	9	13	16	16	11
L_{W2}	54	45	40	37	35	32	28	26
Ceiling reduction	4	4	4	4	4	4	4	4
Room attenuation	6	6	5	5	4	4	4	4
A-weighting	-26	-16	-9	-3	0	1	1	-1
Corrected level	18	19	22	25	27	25	21	17

Sound pressure level of case-radiated noise
 L_{pA2} approx. **32 dB(A)**

Result: In a deviation from the quick selection, different room attenuation values have been assumed. However, the result remains within the requirement.

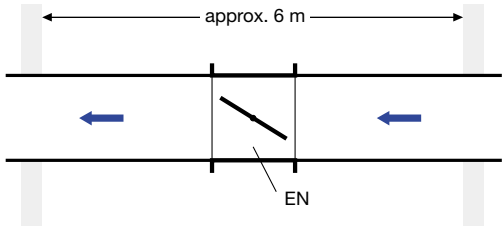
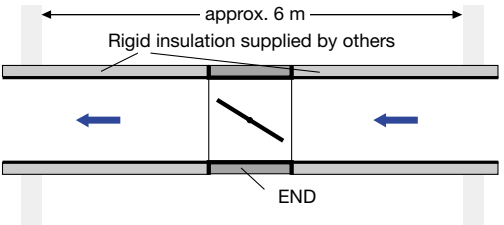
Correction values for case-radiated noise in dB(A)									
Installation location	$\Delta L_W / \Delta L_{W1}$	$\Delta L_W / \Delta L_{W1}$ in dB, related to f_m in Hz							
		63	125	250	500	1000	2000	4000	8000
EN  $L_{W2} = L_W - \Delta L_W$	ΔL_W	4	5	4	9	13	16	16	11
END (with acoustic cladding)  $L_{W3} = L_W - \Delta L_{W1}$	ΔL_{W1}	7	8	10	19	25	29	28	20

Specification text *

Rectangular volume flow controllers for constant volume systems, mechanical system-powered (external power supply not required), for supply and extract air, in 19 nominal sizes. Consists of a casing with a control damper blade shaft mounted, supported on bearings with a bellows and an external cam plate with leaf spring.

Special features:

- Mechanical system-powered, without external power supply
- Low-friction bellows, also operates as an oscillation damper
- The flow rate can be set with an external scale
- Close tolerances on flow rate
- Independent of orientation and maintenance-free

The basic construction of controller is supplied with a set reference flow rate (the required flow rate should be set on site by the customer).

The casing has flanges on both ends suitable for System 30 connecting sections. Differential pressure range 50 to 1000 Pa, flow rate range 4 : 1.

Materials:

Casing and control damper blade are made of galvanised sheet steel, the control damper blade shaft is supported by plain bearings – with PTFE bearing coating. Polyurethane bellows.

Options:

Actuator, 24 VAC or 230 VAC for setpoint value readjustment.

Additional acoustic cladding to reduce case-radiated noise. Consists of 40 mm mineral wool and outer cover of galvanised sheet steel. This gives a reduction of case-radiated noise of minimum 6 dB providing the upstream and downstream ducting has a rigid external insulation. Cannot be retrofitted.

TX silencer, for the reduction of air-regenerated noise, insertion loss approx. 9 dB at 250 Hz. Lining of mineral wool conforming to DIN 4102, fire rating class A2, with RAL quality mark RAL-GZ 388, biodegradable pursuant to TRGS 905 and EU directive 97/69/EG. Mineral wool faced with fibre-glass as protection against erosion, suitable for air velocities up to 20 m/s, inert to fungal and bacterial growth.

* Text for standard construction;
for the actuators, see the design programme or price list

Order code

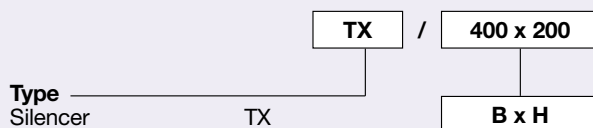
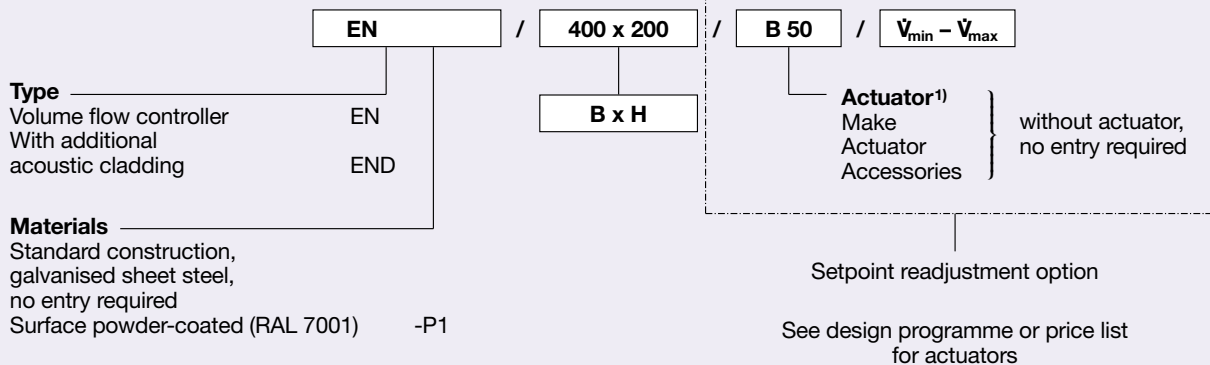

Note:

400 mm high EN flow rate controllers consist of two controllers mounted one above the other. Each controller should then be set to 50 % of the required flow rate on site. These units can only be supplied as EN/END constant flow controllers, but not with actuators.

1) The minimum and maximum setpoint flow rates are set on the construction with an actuator.

EN order example

Make: TROX
Type: EN / 400 x 200

TX order example

Make: TROX
Type: TX / 400 x 200

