

# Volume Flow Limiter

- Type VFL
- for insertion into air ducting

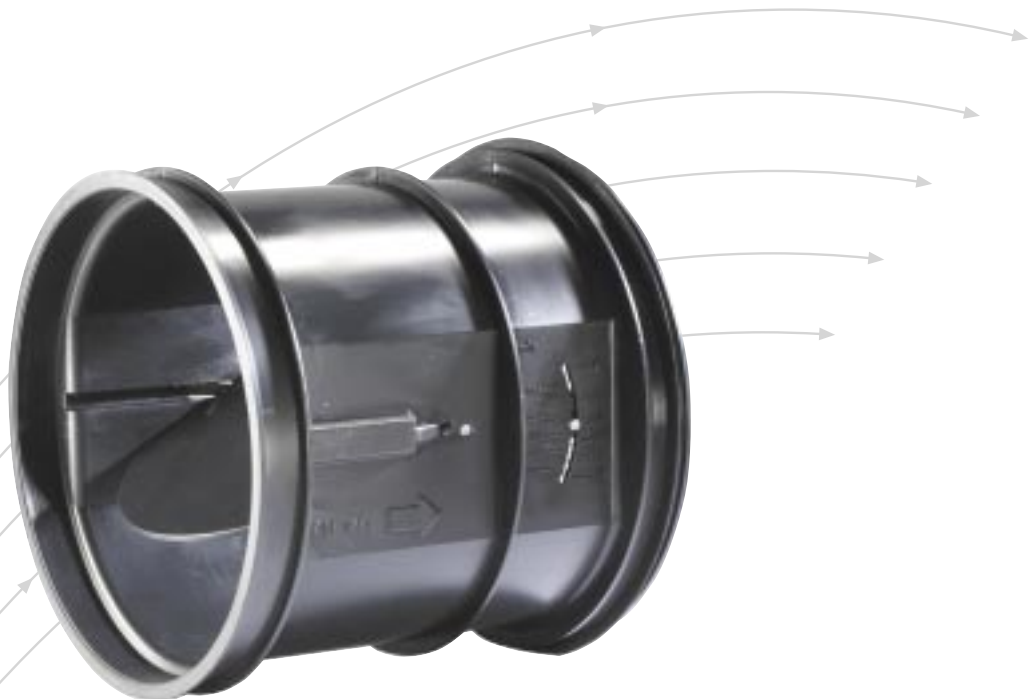

**TROX<sup>®</sup> TECHNIK**

The art of handling air

# Contents

Description _____	3	Acoustic data _____	4
Dimensions _____	3	Installation notes _____	5
Nomenclature _____	4	Order details _____	6
Technical data _____	4		

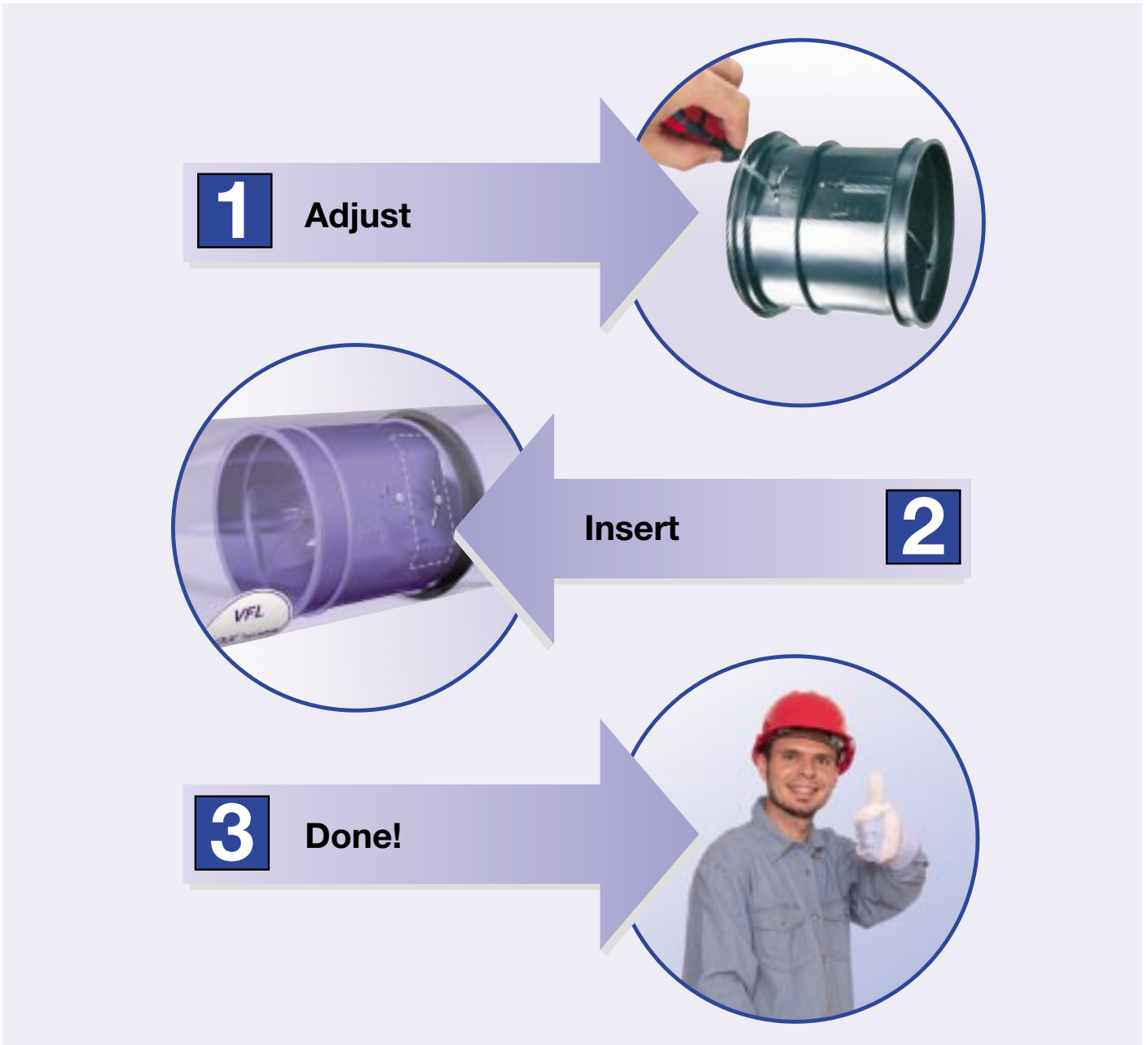

# Description · Dimensions

## Description

The VFL volume flow limiter simply deals with what is normally the tedious and expensive process of adjusting flow rates in ventilation and air conditioning systems. Easy installation and precise operation saves precious time on site.

The required flow rate can be simply set up at the point of installation when the VFL is fitted into the ductwork. The VFL controls to the set flow rate keeping it constant within close tolerances even when the upstream pressure changes.

## Characteristics

- Very close control accuracy for the flow rate settings, to approx.  $\pm 10\%$  relative to  $V_{nom}$
- Flow rate range  $> 5 : 1$ , accurately adjustable
- Mechanical system-powered
- Differential pressure range 30 to 300 Pa
- Independent of orientation
- Maintenance-free
- Operating temperature range 0 to 50 °C
- Storage temperature range -20 to +60 °C
- Stainless steel leaf spring
- Low-friction oscillation damper
- High-quality plastic control damper and casing (UL 94 V1), conforming to DIN 4102, fire rating class B2
- Suitable for circular ducts to DIN EN 1506 and DIN EN 13180



- 1 Control damper blade with oscillation damper
- 2 Leaf spring
- 3 Lip seal
- 4 Setpoint value adjustment

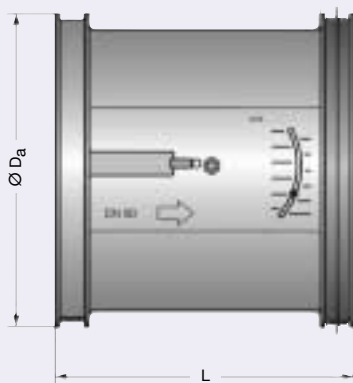

Dimensions in mm			Weight in kg
Size	Ø D <sub>a</sub>	L	Weight
80	78	86	0.10
100	98	100	0.15
125	122	118	0.25
160	156	148	0.40
200	196	175	0.50
250	246	220	0.70

# Nomenclature · Technical Data · Acoustic Data

## Nomenclature

- $\dot{V}$  in m<sup>3</sup>/h or l/s: Flow rate
- $\dot{V}_{nom}$  in m<sup>3</sup>/h or l/s: Nominal flow rate (100 %)
- $\Delta p_g$  in Pa: Total pressure differential
- $\Delta p_{g \min}$  in Pa: Minimum total pressure differential
- $L_{pA}$  in dB(A): A-weighted sound pressure level of air-regenerated noise in the room including duct end reflection and 8 dB/Oct. room attenuation

All sound pressure levels are based on 20 µPa.

**Flow rate setpoint values**

Size	$\dot{V}$											$\dot{V}_{nom}$
	m <sup>3</sup> /h	15	20	25	35	45	60	75	-	-	-	
80	m <sup>3</sup> /h	15	20	25	35	45	60	75	-	-	-	90
	l/s	4	6	7	10	13	17	21	-	-	-	25
100	m <sup>3</sup> /h	15	20	25	30	40	50	60	70	90	100	120
	l/s	4	6	7	8	11	14	17	19	25	28	33
125	m <sup>3</sup> /h	40	50	60	70	85	100	120	140	160	185	205
	l/s	11	14	17	19	24	28	33	39	44	51	57
160	m <sup>3</sup> /h	50	75	100	125	150	175	200	225	250	300	350
	l/s	14	21	28	35	42	49	56	63	69	83	97
200	m <sup>3</sup> /h	60	85	110	150	185	230	290	350	410	485	570
	l/s	17	24	31	42	51	64	81	97	114	135	158
250	m <sup>3</sup> /h	125	170	220	290	370	450	550	640	750	-	900
	l/s	35	47	61	81	103	125	153	178	208	-	250

  Reference flow rate

**Control characteristics**

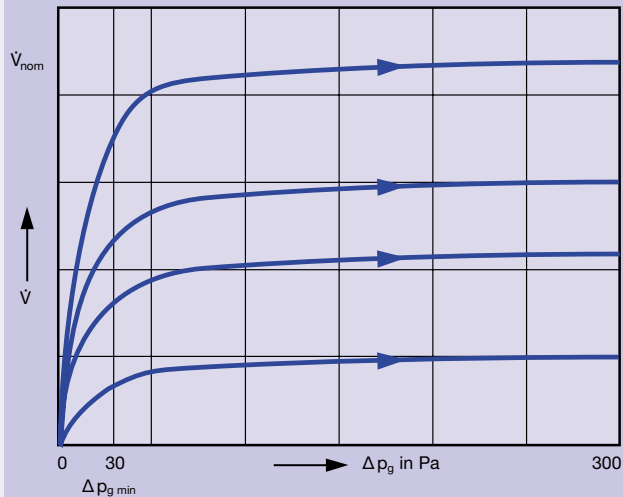

**Sound pressure level  $L_{pA}$  in dB(A)**

Size	$\dot{V}$		$\Delta p_g = 50 \text{ Pa}$	$\Delta p_g = 100 \text{ Pa}$
	m <sup>3</sup> /h	l/s	dB(A)	dB(A)
80	15	4	25	32
	25	7	26	32
	45	13	27	33
	60	17	28	34
	90	25	28	35
100	15	4	28	34
	30	8	29	35
	50	14	30	36
	90	25	31	37
	120	33	32	38
125	40	11	34	38
	70	19	34	39
	100	28	35	40
	160	44	36	41
	205	57	36	42
160	50	14	29	37
	100	28	31	39
	175	49	33	40
	250	69	34	41
	350	97	35	42
200	60	17	26	34
	185	51	28	35
	350	97	29	36
	485	135	30	37
	570	158	31	37
250	125	35	25	34
	285	79	27	35
	550	153	29	37
	750	208	30	38
	900	250	31	39

## Installation

The required flow rate is simply set on site at the point of installation. The slot must then be closed with a sticker supplied to ensure best acoustic performance. The limiter can now be slid into the duct.

The minimum straight upstream duct should be at least 1 D.

## Identification of the installation location

Stickers are supplied for identifying the flow volume limiters once installed. These may be filled in by hand and affixed to the outside of the duct in an easily visible location.

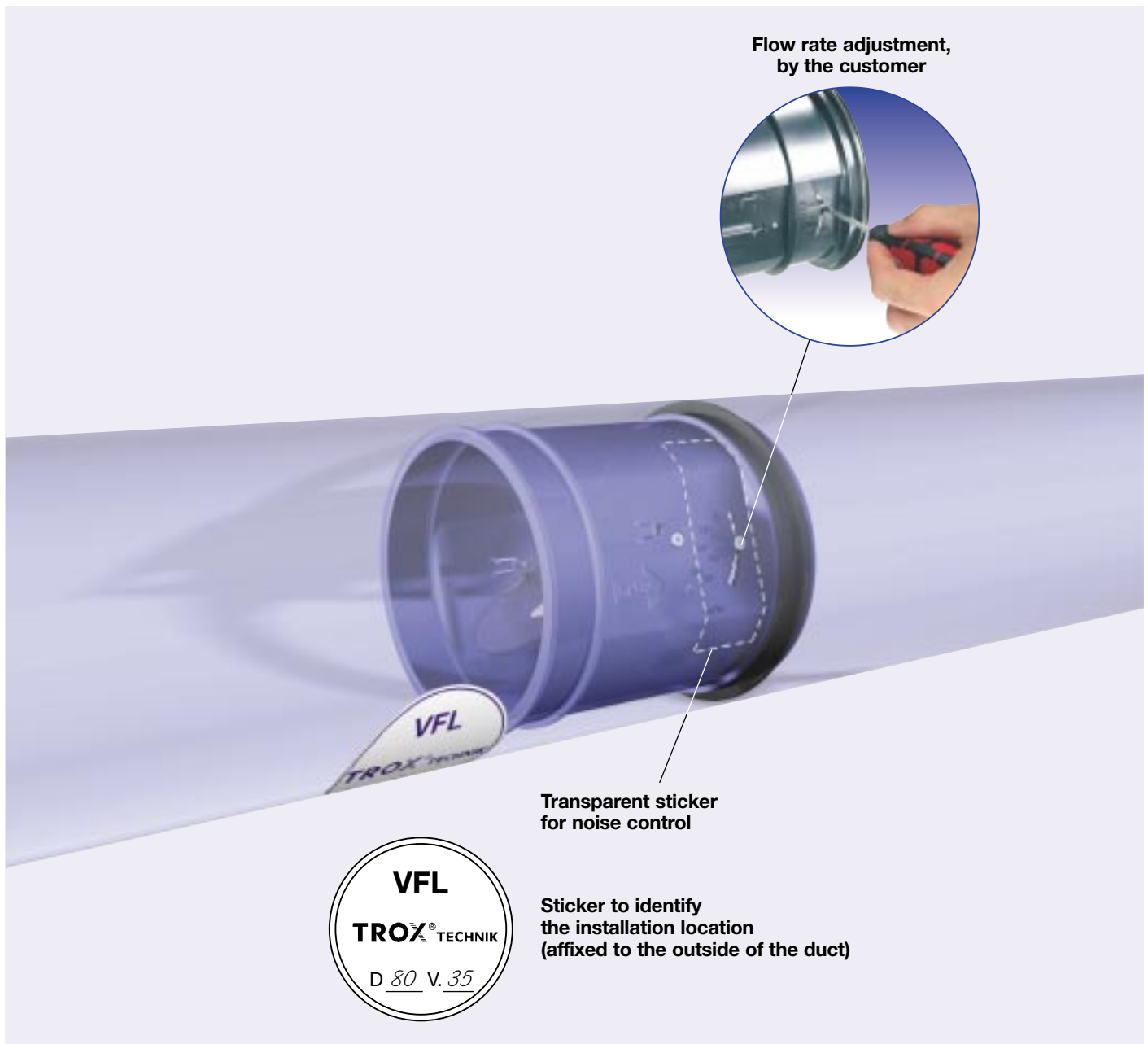

# Order Details

## Specification text

Circular volume flow limiter Type VFL in 6 nominal sizes, manufactured from high quality plastic (UL 94 V1) conforming to DIN 4102, fire rating class B2, for constant flow rate control, for use in air conditioning and ventilation systems, consists of a regulator with set point adjustment, the regulation mechanism with leaf spring and low friction, silicone free oscillation damper.

Special characteristics:

- Mechanical system-powered with a control damper
- Very close control accuracy of approx.  $\pm 10\%$ , relative to  $\dot{V}_{nom}$  in the pressure range between 30 and 300 Pa
- Independent of orientation and maintenance-free

Easy installation into circular ducting; snug fit ensured by a lip seal.

Tested for function and set to a reference flow rate in the factory.

Within a flow rate range of  $> 5 : 1$  may be subsequently accurately adjusted.

## Order code

Type ———— VFL / 100

Nominal size	Reference flow rate $\dot{V}^{1)}$	
	m <sup>3</sup> /h	l/s
80	35	10
100	70	19
125	100	28
160	150	42
200	290	81
250	450	125

- 1) Factory setting of different flow rate setpoint values can be offered at extra costs, only for quantity as of 50 per each size and flow rate.  
See table on page 4 for range of values available as a function of size.