

# Marine Fire and Gas Dampers

Type JFD

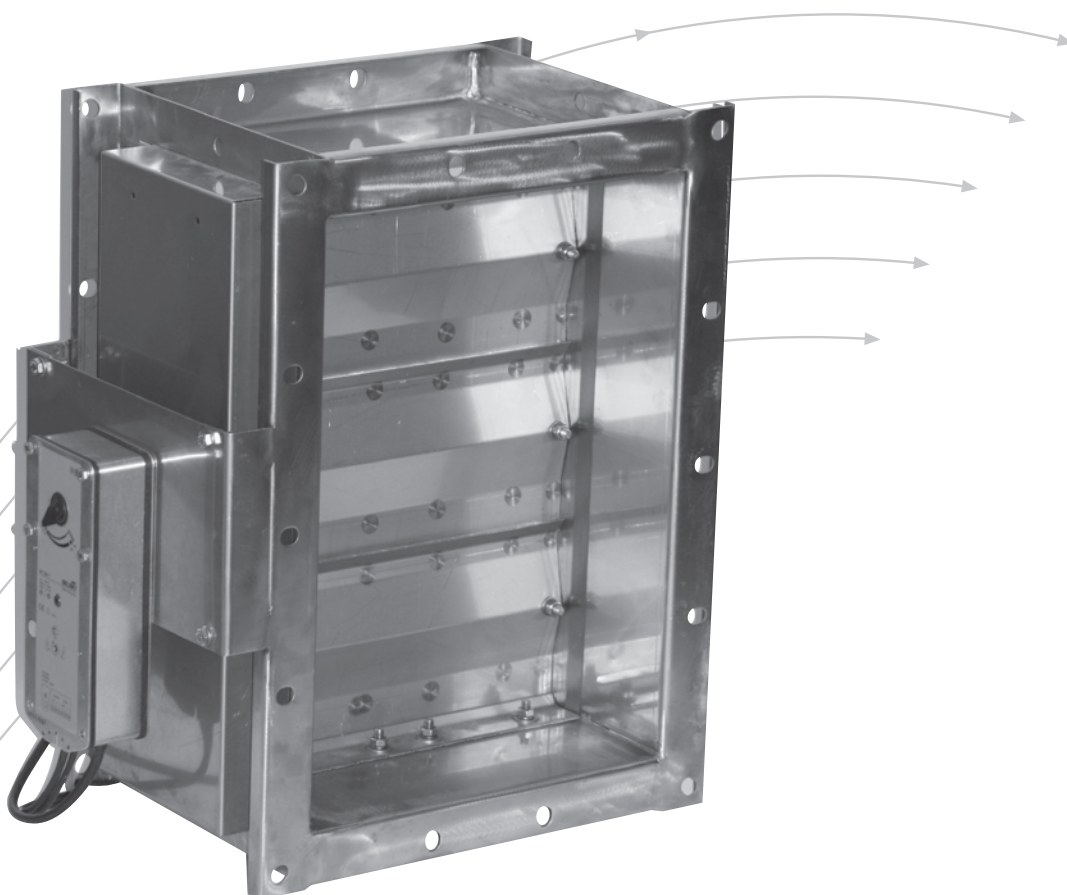

## TROX<sup>®</sup> TECHNIK

TROX Malaysia Sdn. Bhd.  
20 Persiaran Bunga Tanjung 1  
Senawang Land Industrial Park  
70400 Seremban  
Negeri Sembilan Darul Khusus  
Malaysia

Telephone + 606-678 8188  
Telefax + 606-678 8288 / 388  
E-mail enquiry@troxmal.com.my  
www.troxapo.com

# Contents · Description

Description _____	2
Construction; Materials; Standard Sizes _____	3
Product Range; Performance data _____	5

Accessories _____	6
Order Details _____	7

TROX Type 'JFD' Damper is a Multi-leaf Fire and Gas Damper, designed for marine and offshore applications. The damper is certified by Lloyd's Register and ABS for the compliance with IMO Fire Test Procedures Code, Annex 1; Part 3. The damper is also certified by Lloyd's Register for compliance with the essential Fire protection requirements of the EU Marine Equipment Directive (MED) 96/98/EC. The damper is certified for horizontal or vertical mounting in 'A-0' divisions, and 'A-15', 'A-30' and 'A-60' divisions when suitably insulated.

The damper is also certified for use in Zone 1 and 2 hazardous areas and complies with EU Directive 94/9/EG (ATEX 95), Appendix 1 and is classified under equipment group II, category 2G. In accordance with EU Directive 99/92/EC (ATEX 137), the damper can be used in potentially explosive environment where gas Groups IIA, IIB and IIC, and flammable materials at temperature classes T1 to T6 are present.

The maximum recommended operating pressure for this damper is 3000 Pa.

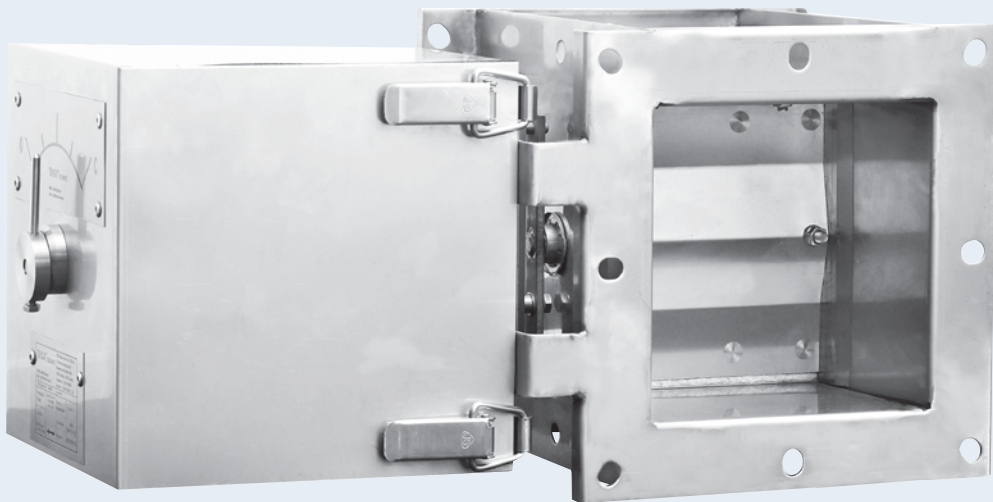

'JFD' Marine Fire and Gas Damper with actuator enclosure

## Type 'JFD' Marine Fire and Gas Dampers

### Damper Casing

2mm thick formed channel sections. 300mm wide (200mm option) with 50mm return flanges on both faces and provided with lifting eyes. Case sections are fully welded externally at corner joints. All welds on the damper face to be ground flush. Damper casing material thickness from 3 mm to 10mm can also be provided. Flanged circular spigots for connection to circular ducts can be provided.

Material – Available in either galvanised steel or stainless steel grade 304, 316 or 316L as required.

### Damper Blades

1.2mm thick-formed aerofoil sections, spot-welded together to form a double skin insulated blade. Blades have opposed action and the linkage geometry allows the blades to interlock to form an effective fire barrier.

Material – Available in either galvanised steel or stainless steel to grade 304 316 or 316L as required.

### Bearings

20mm flanged oil impregnated sintered bronze bearings are pressed into the channel sections of the damper casing to support the blade shafts.

Material – Oil impregnated sintered bronze.

### Shafts

20mm stub shafts at each end of the aerofoil blades Shafts are bolted to the blade section with M8 set of screws, nuts and washers.

Material – Stainless steel 316L.

### Drive Couplings

Pinned to shaft and comprising of two 20mm wide x 6mm thick flat steel sections welded to the 20mm drive shaft machined to suit the actuator.

Material – Stainless steel 316L.

### Linkage

Pinned to shaft and comprising a 20mm wide x 6mm thick flat steel section with 8mm linkage pins. Geometry designed for accurate blade phasing.

Material – Stainless steel 316L

### Cross Link

20 x 6mm flat sections located on linkage pins and retained by star lock washer.

Material – Stainless steel 316L

### Linkage Cover

1mm top hat section to protect damper linkage and allow application of insulation (by others).

Material – Available in either galvanised steel or stainless steel to grade 304, 316 or 316L as required.

### Side seals

Roll formed from 75 x 0.3mm hardened and ground stainless spring steel.

Material – Stainless spring steel.

### Blade Edge Seals (Provided as optional extra if requested)

Retained in blade edge 'V' groove with fix wool adhesive. Provides leakage rate in accordance with UL555S Class 1 (less than  $0.04\text{m}^3/\text{s}/\text{m}^2$  damper face area at 1125 Pa).

Material – Kerlane ceramic fibre.

### Actuator mounting angles

2.0mm thick formed angle sections welded to damper casing with pre-drilled holes to suit actuator-mounting plate.

Material – Available in either galvanised steel or stainless steel to grade 304, 316 or 316L as required.

### Landing angles

43mm x 7.5mm x 2mm angles bolted to the top and bottom of the damper casing to provide blade stop and seal.

Material – Available in either galvanised steel or stainless steel to grade 304, 316 or 316L as required.

### Finish

This will be in natural finish of the material from which the damper is made. For galvanised sheet steel, all burrs will be removed and welds on the damper surface ground flushed and finished with zinc rich paint.

# General Details

**Table 1:** Minimum and Maximum Damper Size

	Standard Module Size (mm)	
	Width (B)	Height (H)
Minimum size	200	200
Maximum size	1050	1250

**Note:**

The breadth (B) and height (H) are external duct dimensions.

1	Damper casing	2 mm GMS or stainless steel
2	Double skin (aerofoil) damper blade	1.2 mm GMS or stainless steel
3	Stub shaft	20 mm Ø shaft in stainless steel
4	Side seal	Stainless steel spring
5	Tip seal	Kerlane cord
6	Linkage assembly	GMS or stainless steel
7	Cross link bar	GMS or stainless steel
8	Actuator mounting plates	GMS or stainless steel
9	Linkage cover	GMS or stainless steel
10	Bearings	Olite bronze
11	Insulation	60 kg/m <sup>3</sup> Rockwool
12	Landing angle	GMS or stainless steel

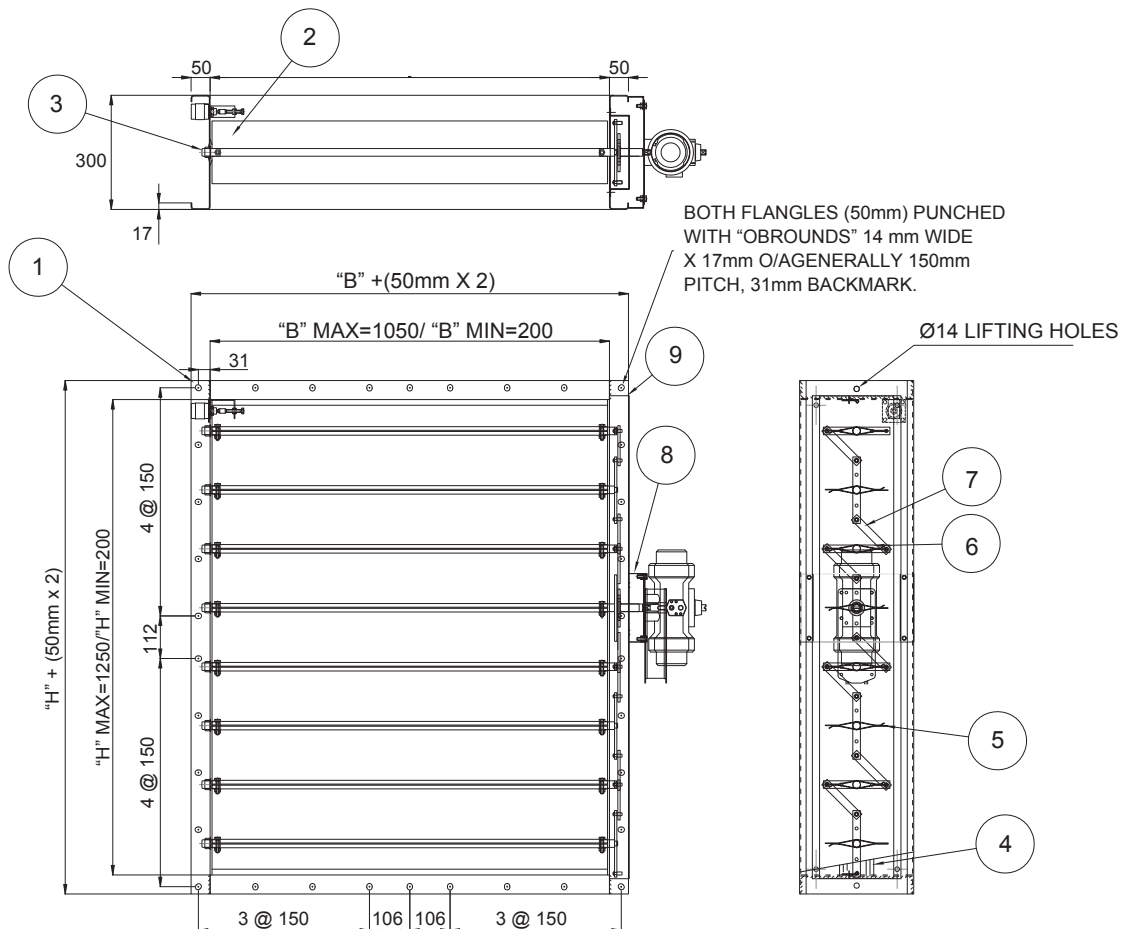

# Product Range · Performance Data

## Type JFD

### Material options

Construction Variants	Description
<b>G</b>	<b>In galvanised steel. Standard supply.</b>
E1	In grade 304 stainless steel.
E2	In grade 316 stainless steel.
E3	In grade 316 L stainless steel.

### Seal options

Seal Variants	Description	Leakage rating to UL 555S
FL1	With side seals only.	Class II
<b>FL2</b>	<b>Standard supply with side and blade tip seals to minimise closed blade leakage.</b>	Class I

### Flange options

Flange Variants	Description
F1	30 mm wide flange
F2	40 mm wide flange
<b>F4</b>	<b>50 mm wide flange. Standard supply</b>
F6	65 mm wide flange
F7	75 mm wide flange
F8	80 mm wide flange

### Extended Flange on One Side

Extended Flange Variants	Description
<b>0</b>	<b>No extended flange. Standard supply</b>
50	50 mm extended flange.
80	80 mm extended flange.
100	100 mm extended flange.
150	150 mm extended flange.

### Drilling options

Drilled flange Variants	Description
<b>0</b>	<b>Undrilled. Standard supply</b>
G1	40 mm drilled flange
G2	50 mm drilled flange
G3	To customer's requirements

Pressure drop across JFD Damper with blades in fully open position

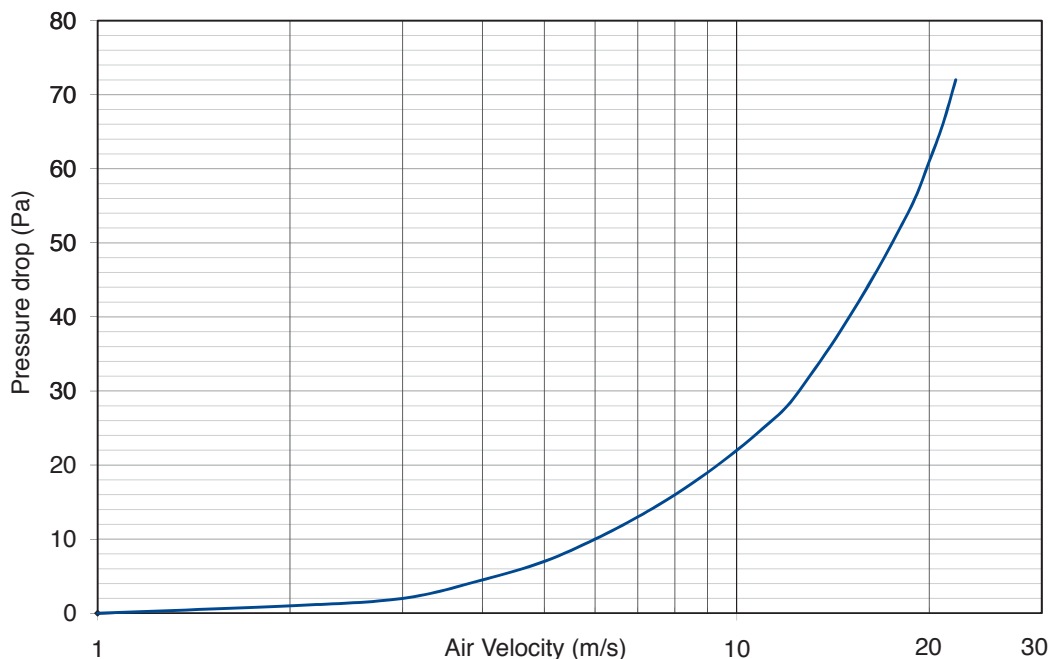

# Accessories

**Table 1:** Types of Actuator and limit switches

Mode of operation	Type of construction variants and mode of operation	Fail safe setting	Product Coding
With pneumatic spring return actuator	With actuator only (Standard Supply)	FC	Z 10
	Complete with actuator and limit switch(es); • Limit switch to indicate "Open" position.	FO	Z 11
	• Limit switch to indicate "Closed" position.	FC	Z 12
	• Limits switches to indicate "Closed" and "Open" positions.	FO	Z 13
		FC	Z14
With electric spring return actuator	With spring return actuator, operating at 230v; 50/60 Hz with IP 54 rating. Typical cycle time for motor is 150 s (or seconds) and under spring force is 20 s <u>unless</u> stated otherwise. <b>Note:</b> Electric actuators for operation in hazardous areas and with fast operating times are available. Please contact TROX for further details.		
	• Actuator without integral limit switches to indicate "Open" and closed position.	FC	Z 20
	• Actuator with integral limit switches to indicate "Open" and closed position.	FO	Z 21
		FC	Z 22
	• Actuator with an independent limit switch to indicate "Open" position.	FO	Z 23
	• Actuator with an independent limit switch to indicate "Closed" position.	FC	Z 24
	• With independent limit switches to indicate "Open" and "Closed" positions.	FO	Z 25
FC		Z 26	

**Table 2:** Other ancillary Components

Item	Type	Description	Product Coding (A)
1	Thermal Trip Device	Electro-thermal trip device rated at 72°C for electric actuator	1
		Electro-thermal trip device rated at 95°C for electric actuator	2
		3-port, 2 position SS 316 valve (as standard supply), which is operated by a frangible bulb rated at 68° and is suitable for pneumatic actuators.	3
2	Quick Release Valve for pneumatic actuators only.		4
3	Junction Box		5
4	Earth Continuity Box		6
5	Solenoid Valve		7
6	Hand Valve		8
7	Pressure Regulator & Gauge		9
8	Limit Switches	V3 Mechanical Switches (SPDT)	10
		Herm Sealed Proximity Switch	11
		P&F Switches (NJ2-V3) Eexia	12
9	Actuator/Controls Enclosure	1.2mm thick material with removable cover	13

## Order Code for Type 'JFD' Damper

**Note:** If the order codes below are incomplete, then it is assumed that standard damper construction is required.

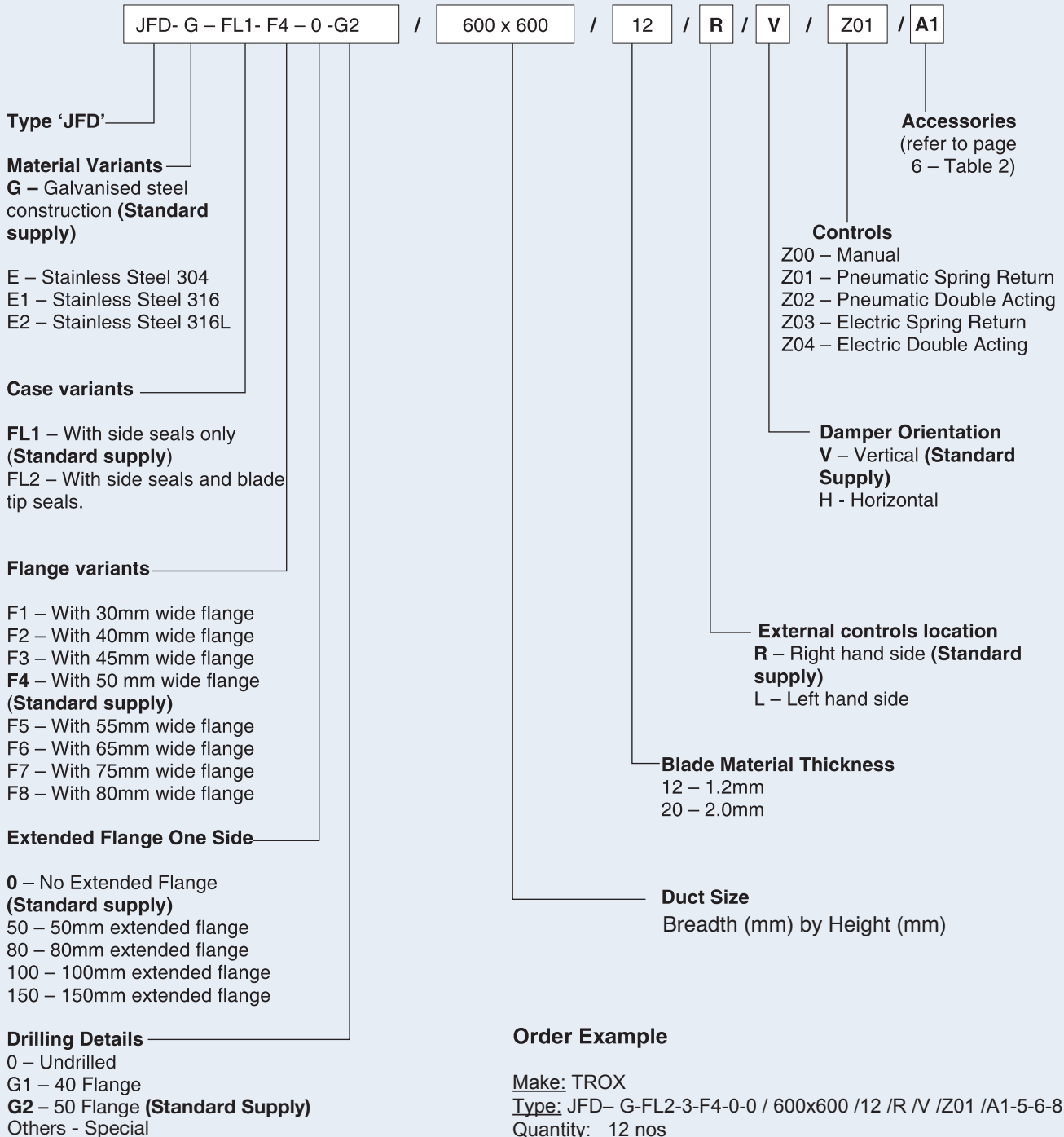

### General Specification:

The Type 'JFD' is certified by the Lloyd's Register and ABS in accordance with the IMO Fire Test Procedures Code, Annex1, Part 3, and it is suitable for both marine and offshore applications.

