

Shut Off Damper

Type NAK (gas tight)



TROX[®] TECHNİK

TROX GmbH
Heinrich-Trox-Platz
D-47504 Neukirchen-Vluyn

Telephone +49/28 45/2 02-0
Telefax +49/28 45/2 02-2 65
e-mail trox@trox.de
www.troxtechnik.com

Contents · Description

Description _____	2	Circuit diagrams _____	6
Construction _____	3	System diagrams · Technical data _____	7
Construction · Standard sizes _____	4	Order details _____	8
Functional description · Product range _____	5		

NAK-H



NAK-P



Shut off dampers are designed such that they can isolate sections of a ventilation system with a very high level of sealing (gas tight). This can be required for safety reasons in certain operational conditions.

Type NAK shut of dampers are designed so that after closure, even with failure of power supply to the actuator, the damper maintains the sealed closure in accordance with KTA 3601 (Guidelines for Nuclear Plant). The compact design and robust actuator mechanisms of these shut-off dampers enable them to be installed in any orientation.

NAK-E



Type NAK-H · NAK-H-G · NAK-P · NAK-P-G

NAK-H

- Case and blades of sheet steel, undercoated with an electro-dipcoat process, top coated with polyurethane paint, colour grey (RAL 7001)
- Bearing assemblies stainless steel or brass
- Seals neoprene foam rubber material, heat resistant to 80 °C
- Drive shafts, stops and other attachments in galvanised steel
- Hand wheel drive
- Maximum pressure loading 5000 Pa (in closing direction)
- Maximum leakage to KTA 3601 (0.01 m³/h x m² with a pressure differential of 2000 Pa)

NAK-H-G

As type NAK-H but casing flanges at both ends drilled

NAK-P

As type NAK-H, but:

- without threaded drive shaft and handwheel
- with double acting pneumatic actuator (operating pressure 6 bar) and adjustable throttling valve

NAK-P-G

As type NAK-P but casing flanges at both ends drilled

- ① Case
- ② Blade
- ③ Drive linkage (over centre locking)
- ④ Seal
- ⑤ Hand wheel
- ⑥ Pneumatic actuator with throttling valve

Type NAK-H · NAK-H-G

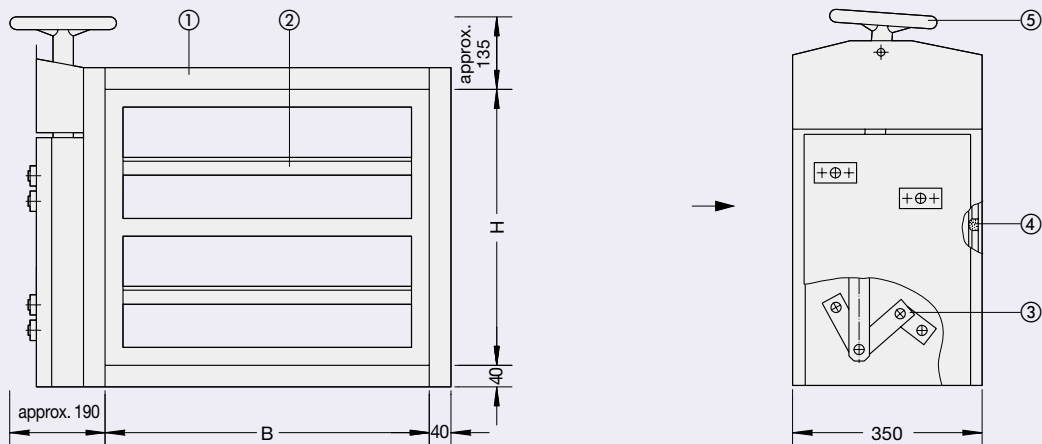

Type NAK-P · NAK-P-G

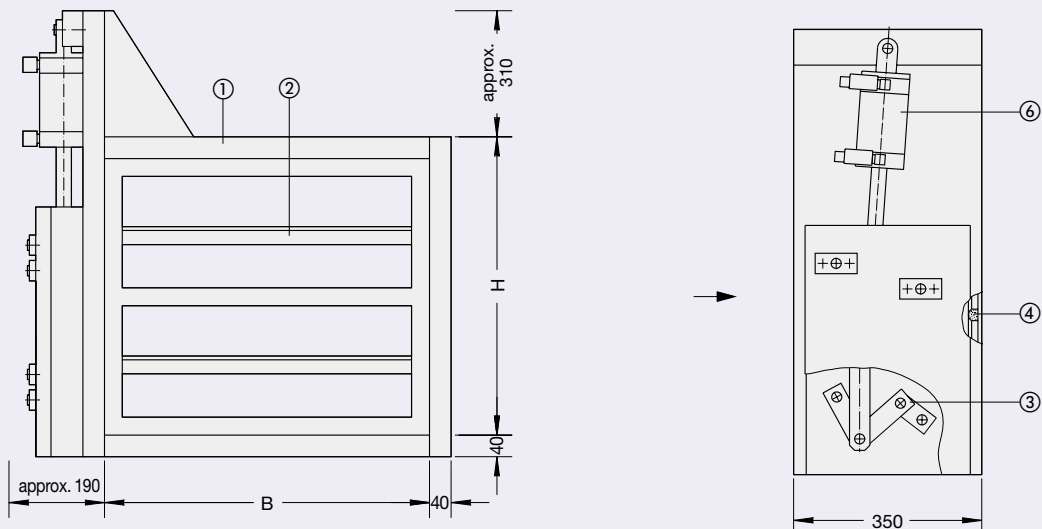

Shown with controls on the right hand side "R" when viewed in direction of arrow

Construction · Standard Sizes

Type NAK-E · NAK-E-G · NAK-E1 · NAK-E1-G

NAK-E

- Case and blades of sheet steel, undercoated with an electro-dipcoat process, top coated with polyurethane paint, colour grey (RAL 7001)
- Bearing assemblies stainless steel or brass
- Seals neoprene foam rubber material, heat resistant to 80 °C
- Drive shafts, stops and other attachments in galvanised steel
- Operation by electric actuator 400 V / 50 Hz
- Maximum pressure loading 5000 Pa (in close direction)
- Maximum leakage to KTA 3601 (0.01 m³/h x m² with a pressure differential of 2000 Pa)

NAK-E-G

As type NAK-E but casing flanges at both ends drilled

NAK-E1

As type NAK-E, but with electric actuator 230 V / 50 Hz

NAK-E1-G

As type NAK-E1 but casing flanges at both ends drilled

- ① Casing
- ② Blade
- ③ Drive linkage (over centre locking)
- ④ Seal
- ⑦ Electric actuator with handwheel for manual operation in the event of a power failure

Type NAK-E · NAK-E-G · NAK-E1 · NAK-E1-G

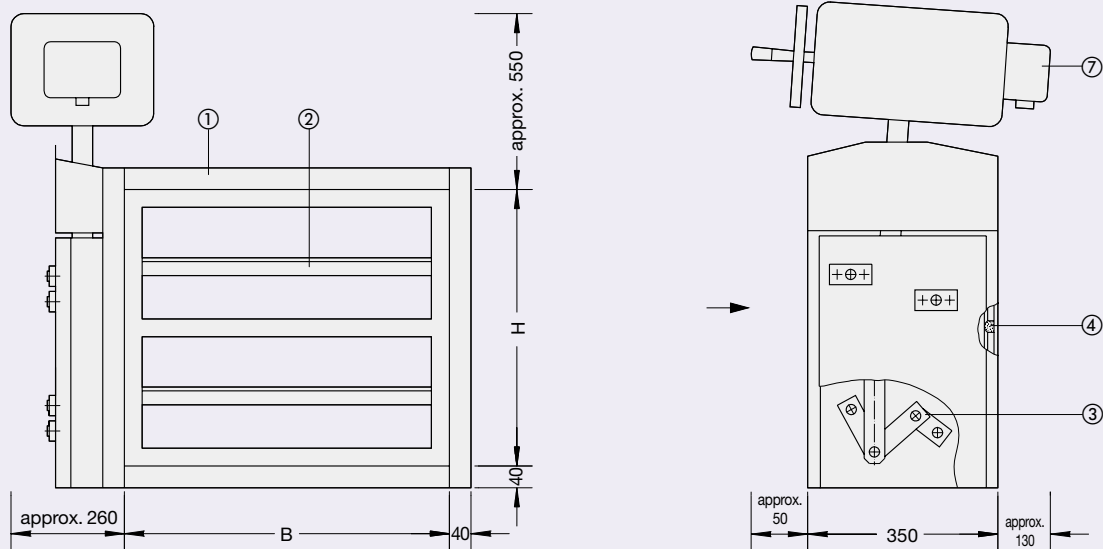

Shown with controls on the right hand side "R" when viewed in direction of arrow

Standard sizes

B in mm	H in mm	Number of blades	Free cross sectional area in %	Number of holes	
				per B dim.	per H dim.
400	270	1	approx. 60	4	3
600	510	2	approx. 70	5	5
800	755	3	approx. 74	7	7
1000	1000	4	approx. 76	8	9

Any combination of dimensions B x H listed above can be supplied

Functional Description · Product Range

Functional description

- Damper with manual operation
Damper closed by approx. 30 clockwise rotations of handwheel,
Damper opened by approx. 30 anti-clockwise rotations of handwheel.
- Damper with pneumatic operation
Damper closed or opened by application of control pressure to the double acting pneumatic actuator.
A multi-way valve is used to change direction.
Closing or opening time minimum 2 seconds.
- Damper with electric operation
Damper closed or opened by changing polarity of electric actuator.
Closing or opening time approx. 1 minute.
In the event of a power failure, the damper can be closed or opened manually via a handwheel mounted on the electric actuator.

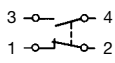
Product range			
Construction	Combined with	Code	
Type NAK-H · NAK-P · NAK-E · NAK-E1	-	-	
	Limit switch to indicate damper "CLOSED"	* Double contact change-over (socket screw connection) Switch rating: 230 V AC, 6 A contact resistance max. 25 mΩ Protection IP 66	Z01
	Limit switch to indicate damper "OPEN"		Z02
	Limit switch to indicate damper "CLOSED" and "OPEN"		Z03
			
Type NAK-P with 4/2-way solenoid - solenoid U = 230 V, 50 Hz P = 9 VA / 5 W (operation) IP 65 / 100 % rating	-		Z04
	Limit switch to indicate damper "CLOSED"	*	Z05
	Limit switch to indicate damper "OPEN"		Z06
	Limit switch to indicate damper "CLOSED" and "OPEN"		Z07
Type NAK-P with 4/2-way pneumatic valve	-		Z08
	Limit switch to indicate damper "CLOSED"	*	Z09
	Limit switch to indicate damper "OPEN"		Z10
	Limit switch to indicate damper "CLOSED" and "OPEN"		Z11

Circuit Diagrams

Circuit example for type NAK-E (400 V, 50 Hz)

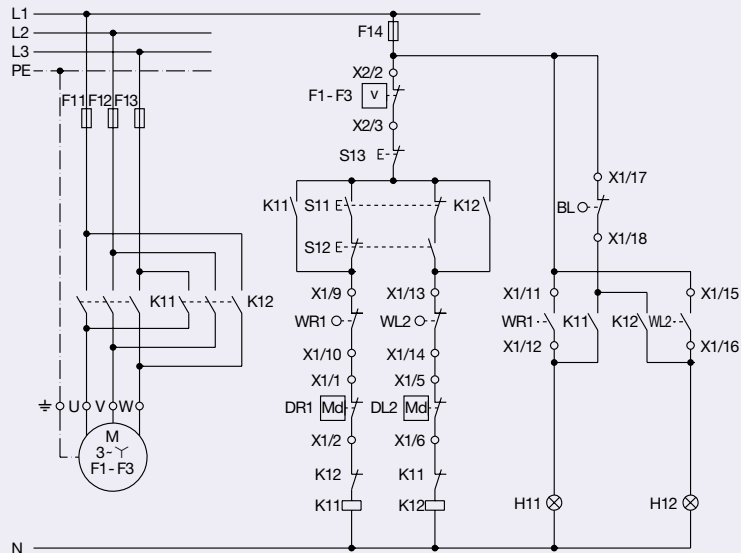

Motor connection

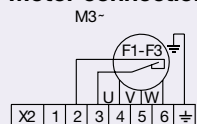

Terminal schedule

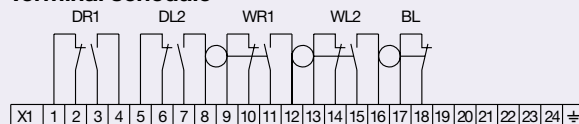

- M Motor (3 ~), S2 = 10 minutes
- M1 Motor (1 ~), S2 = 10 minutes
- DR1 DREHMO torque switch travel – right
- DL2 DREHMO torque switch travel – left
- WR1 Limit switch travel – right
- WL2 Limit switch travel – left
- BL Flasher
- F1–F3 Thermal switches in motor (400 V, 50 Hz)
- F1 Thermal switches in motor (230 V, 50 Hz)
- X1/X2 Terminal block
- S11 Push button for travel – right, supplied by others
- S12 Push button for travel – left, supplied by others
- S13 Push button for stop, supplied by others
- K1/K2 Reversing contactors, K11/K12 supplied by others
- F11 – F13 Motor fuses, supplied by others (400 V, 50 Hz)
- F11 Motor fuses, supplied by others (230 V, 50 Hz)
- F14 Power fuse, supplied by others
- H11/H12 Warning lamps, supplied by others

Circuit example for type NAK-E1 (230 V, 50 Hz)

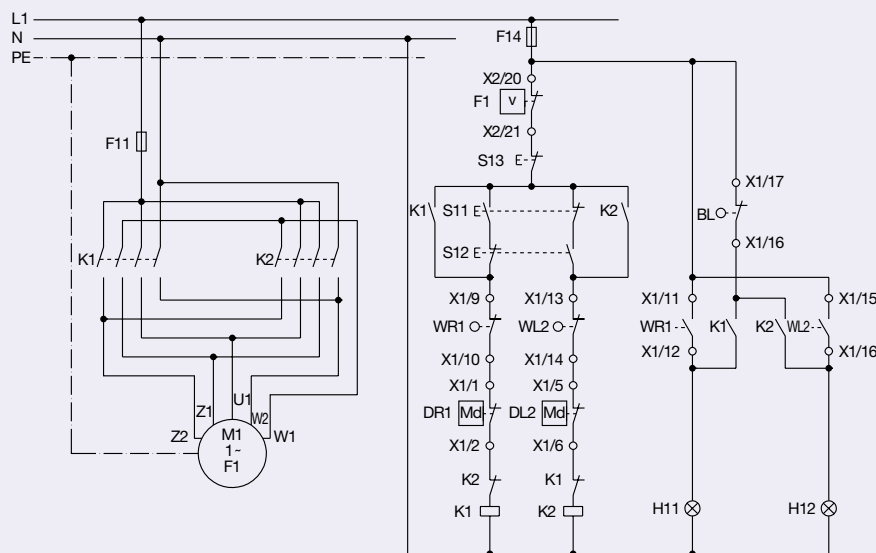

Motor connection

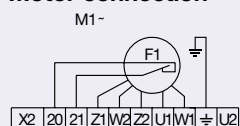

Terminal schedule

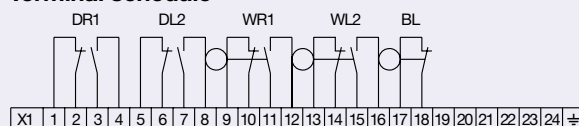

Motor terminal U2 internal wiring

Note:

Travel switches and DREHMO switches are factory set; they must not be adjusted by the customer (risk of damage). To protect the motor, the thermal switches F1–F3 and/or F1 must be connected. The electrical function check must be carried out from the central position of the blades. Ensure that operating push button S11 closes the damper.

System Diagrams · Technical Data

Nomenclature

- v in m/s: Air velocity (related to $B \times H$)
- Δp_t in Pa: Total pressure drop (for ducted installation)

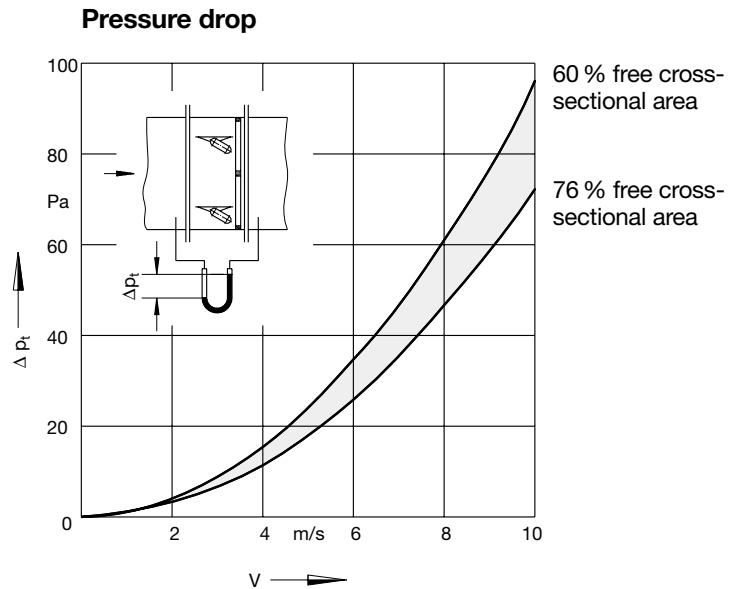

System diagrams for type NAK-P

System diagram 1 (Basic design)

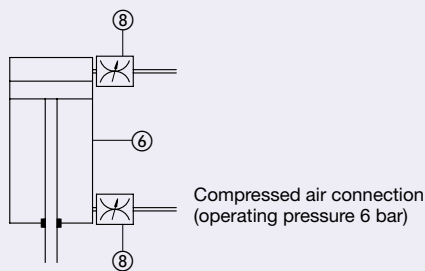

- ⑥ Pneumatic actuator
Air consumption/stroke
≈ 2.6 standard litres ($B \times H < 0.5 \text{ m}^2$),
≈ 3.5 standard litres ($B \times H = 0.5 - 0.7 \text{ m}^2$),
≈ 6.0 standard litres ($B \times H > 0.7 - 1.0 \text{ m}^2$)
- ⑧ Adjustable throttling valve, R 1/4" internal thread
- ⑨ 4/2-way pneumatic valve, R 1/4" internal thread,
mounted directly on to actuator
- ⑩ 4/2-way solenoid with auxiliary manual operation
R 1/4" internal thread, mounted directly on to actuator
- ⑪ Electric switch supplied by others

System diagram 2 (with 4/2-way solenoid)

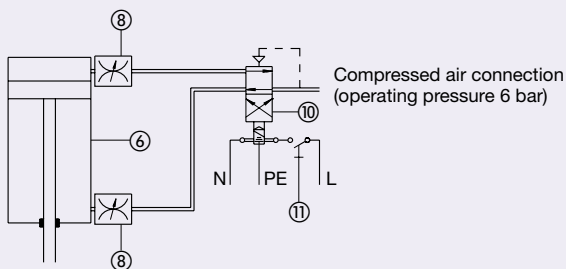

For constructions according to system diagram 1, a multi-way valve must be installed to change direction of control air.

System diagram 3 (with 4/2-way pneumatic valve)

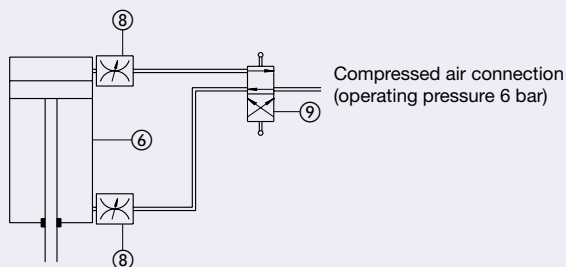

Shown with damper in closed position.

Electric limit switches (double contact change-over) for position indication.

Order Details

Order code

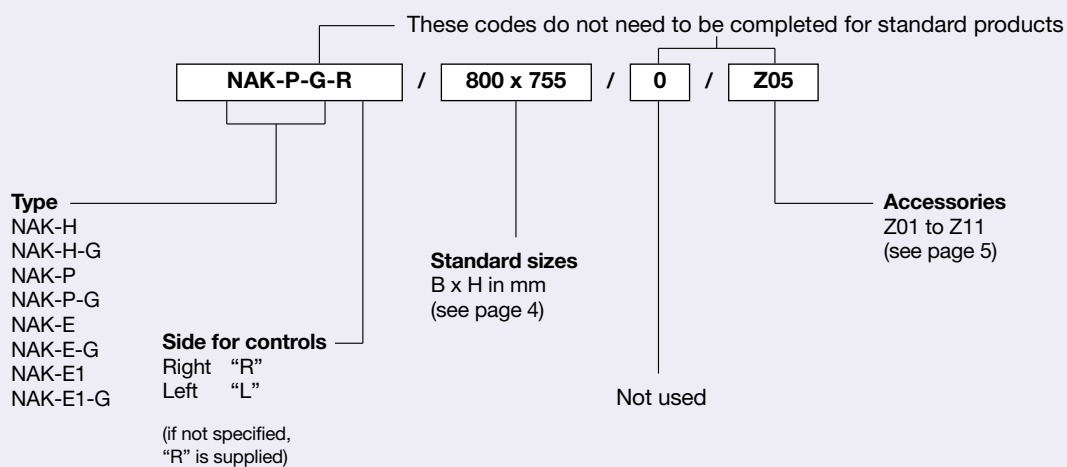

Specification text

Shut off dampers for gas tight sealing of individual sections of ventilation systems with proven seal to KTA 3601 (maximum leakage 0.01 m³/h x m² with a pressure differential of 2000 Pa). Pressure tight to 5000 Pa. The damper mechanism is designed such that after closure, no energy is required to keep the damper in the closed position.

Construction and materials:
 See data on pages 3 and 4

Accessories:
 See data on page 5

Make: TROX

Types: NAK-H · NAK-H-G · NAK-P · NAK-P-G ·
 NAK-E · NAK-E-G · NAK-E1 · NAK-E1-G

Order example

Make: TROX
 Type: NAK-P-G-R / 800 x 755 / 0 / Z05
 Qty.: 3