

Water Side Fan Coil

Type Phantom PWS

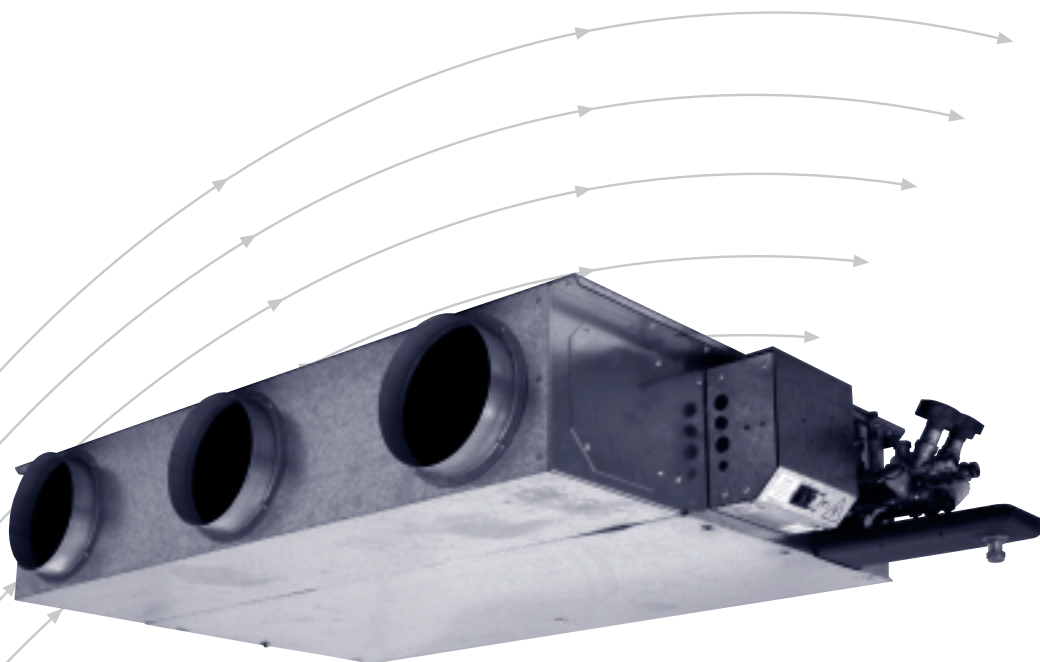

TROX[®] TECHNIK

Trox (U.K.) Ltd
Caxton Way
Thetford
Norfolk IP24 3SQ

Telephone +44 (0) 1842 754545
Telefax +44 (0) 1842 763051
www.trox.co.uk
e-mail trox@troxuk.co.uk

Contents · Application

Contents · Application	2	Noise Rating · Cooling Performance	7
Description · Dimensions	3	Cooling Performance	8 - 10
Specification · Spigot Arrangement	4	Heating Performance	11 - 13
Specification · Electrical Data	5	Order Details	14
Specification · Cooling Performance	6		

Type PWS

- 1 Fan Deck
- 2 Coil
- 3 Control Box
- 4 Spigot
- 5 Discharge Plenum
- 6 Drain Tray
- 7 Spigot Blanking Plate
- 8 Filter

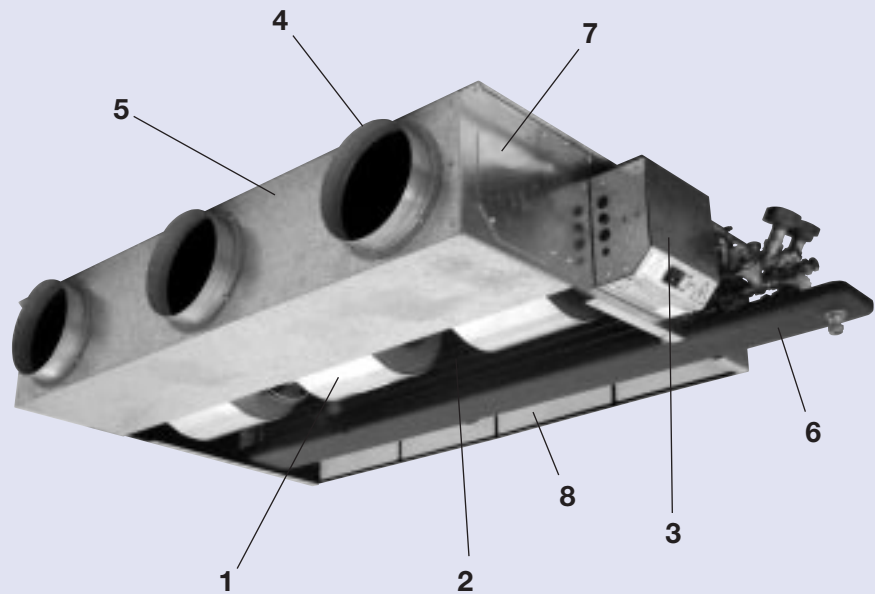

Application

The main application of Phantom PWS is for the air conditioning of offices and hotel rooms. It is designed to be installed into false ceilings or under floor voids. Within the Fan Coil, fresh or re-circulating air is filtered, cooled or heated as necessary and supplied indirectly through spigots, ducts and grilles into the internal space, offering individual and zone control.

System Features and Benefits

- Safe: As a water based system, no refrigerant pipework needs to be installed to link up units, thus there is a reduction in risk, installation time and cost.
- Easy installation: Hot and cold water piping from the central plant boiler and main chiller plus an electrical supply is generally all that is required.

- Reliable and tested: All components are available as standard and have proven reliability. Every unit undergoes a complete functional test in the factory (excludes DDC controller which may be tested by Systems House at works).
- Functional: Can either heat or cool. Also, its decentralised configuration means that it is flexible should the building use or layout need to be changed. Equally, if there is a failure in one unit, this will only affect one area.
- Compact: The standard unit has a height of 245mm and therefore may be located in restricted ceiling voids.
- Flexible: Can easily be adapted, moved or altered if the building requirements change.

Description · Dimensions

Phantom PWS is a range of horizontal concealed chassis water side controlled Fan Coil Units, with integral discharge plenum and options for discharge spigot outlet positions. The units are designed to provide maximum flexibility in thermal, hydraulic and acoustic performance. There are 5 sizes in the PWS range, larger sizes/duties available upon request.

Phantom PWS (water side) is a localised air conditioning unit normally found within non-domestic, non-industrial buildings, such as office blocks, shops, restaurants and hotels.

All units are mill finish galvanised steel, consisting of a galvanised metal shell containing thermal and acoustic insulation, a filter, a heat exchanger, a drain tray, a fan deck assembly and a controls housing.

Phantom PWS operates by bringing either fresh, re-circulating or mixed air from within ceiling voids or directly ducted to the rear of the unit. This is then filtered before being either cooled or heated as it passes over the coil and supplied indirectly through spigots in the discharge plenum to ducts and grilles into the internal space. It is suitable for heating and cooling, offering individual and zone control.

Unit depth is 245mm throughout the range, excluding the drain connection, and excluding a stepped plenum if it is fitted.

Type PWS

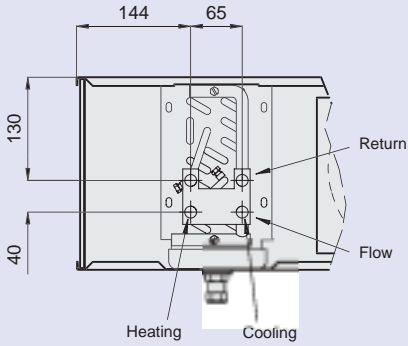
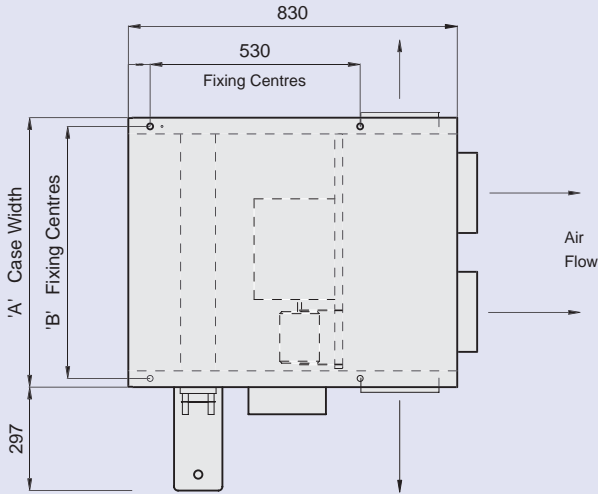

Right hand unit shown
For left hand unit heating and cooling positions are reversed.
Coil tails dia 15mm

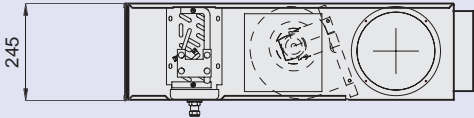

Size	Dim A	Dim B	Weight	Spigot options*
PWS 1	680	636	31	1, 2, 3, 4
PWS 2	980	936	43	1, 2, 3, 4
PWS 3	1280	1236	55	1, 2, 3, 4, 5
PWS 4	1580	1536	70	1, 2, 3, 4, 5, 6
PWS 5	1730	1686	82	1, 2, 3, 4, 5, 6

*see page 4

Specification · Spigot Arrangements

Chassis

The unit casing and integral discharge plenums are manufactured from 1.0mm or 1.2mm galvanised sheet steel, depending on size. The fan deck mounting plate is manufactured from 1.6mm galvanised sheet steel.

All units have a full width access panel for easy maintenance of the coil and fan deck. This access panel is easily removable via a keyhole slot arrangement retained by M5 screws.

The casing and integral plenum is fitted internally throughout with Fire Rated Class 'O' open cell self-adhesive foam for thermal and acoustic insulation.

The unit incorporates an integral external mounting flange with 4 no. 12mm holes for suspension from drop rod hangers.

Drain Tray

A full width condensation drain tray extends the full length of the coil and control valves. It is mounted in position to give a positive fall to drain.

The tray is manufactured from 1.2mm galvanised steel and is externally insulated with 3mm closed cell insulation.

Spigots

Standard spigots are 200mm diameter galvanised steel.

They are externally screwed into position on the plenum box to suit the customer's requirements. Where spigots are not required, a blanking plate will be fixed.

250mm, 300mm and rectangular spigots are available on request with a stepped discharge plenum.

Dimensions - Spigot Arrangements

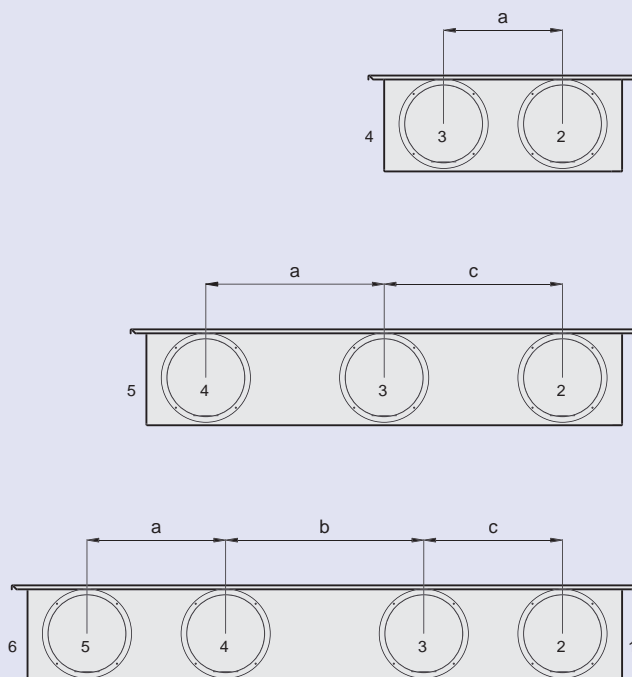

Size	Dim A	Dim B	Dim C	Spigot options*
PWS 1	300	-	-	1, 2, 3, 4
PWS 2	600	-	-	1, 2, 3, 4
PWS 3	450	-	450	1, 2, 3, 4, 5
PWS 4	350	500	350	1, 2, 3, 4, 5, 6
PWS 5	350	650	350	1, 2, 3, 4, 5, 6

Specification · Electrical Data

Coils

The units are fitted with a 3^{1/2} row cooling coil and 1^{1/2} row heating coil as standard for four-pipe operation.

A single coil block incorporates both the heating and cooling sections.

Coils are copper tube/aluminium plate fin construction at 12 fins per inch. They are factory tested and suitable for 12 bar operating pressure.

Coils are fitted with key operated vents and drains in the header block as standard. Coil flow and return connections are at 40mm centres with plain 15mm o/d copper tails suitable for compression fittings.

Fans & Motors

Forward curved DIDW direct-drive centrifugal fans with aluminium impellers are used throughout.

Motors are continuously rated 230V single phase 50Hz with built-in thermal overload protection. Bearings are sealed for life and maintenance free.

The fan/motor assembly is balanced and secured through anti-vibration mounts to the fan deck. Motors drive up to a maximum of three fan scrolls.

Electrical Installation

All wiring must comply with the requirements of BS 7671.

The fan coil requires a 230V 1ph 50Hz supply, fused at 5A.

Note: The fan coil is not fitted with an isolator. The must be isolated externally before any maintenance work is undertaken on the unit.

Fan Motor Data Only

Model Size	Motor Power (W)	Starting current (A)	Running current (A)		
			Low	Medium	High
PWS 1	1 x 40	1.20	0.24	0.39	0.64
PWS 2	1 x 73	1.60	0.30	0.53	1.00
PWS 3	1 x 184	3.75	0.74	1.25	2.00
PWS 4	1 x 184	3.75	0.74	1.25	2.00
PWS 5	2 x 73	3.30	0.65	1.10	2.10

Each unit has a signed test certificate attached to it. This details that the electrical and pressure testing has been completed.

Specification · Cooling Performance

Filters

Units are supplied fitted with a vertical flat replaceable filter pad to Eurovent Grade EU 2/3.

The filter includes an integral welded support frame, is located at the air inlet and is suitable for removal from the bottom or side of the unit.

Controls

All units are fitted as standard with an on/off switch, 3-speed switch and 240/24V multi-tapped transformer.

All units are electrically tested for correct operation and all valve to coil connections are leak pressure tested. Test certificates are provided with all units.

Trox is able to accommodate most types of controls package if required.

When selecting units for a given system there are many factors to take into account.

- Model of unit
- Size of unit
- Unit capacity
- Water temperature
- Unit power consumption
- Noise
- Room conditions
- Controls (if supplied)

Selection Data

Model Size	Guide NR	Air Flow l/s	Total Cooling Kw	Sensible Cooling Kw	Pressure Drop kPa	Fluid Flow l/s
PWS 1	26	70	1.54	1.15	5.28	0.061
	30	85	1.77	1.35	6.73	0.070
	32	100	1.99	1.54	8.33	0.079
	33	115	2.21	1.72	10.09	0.087
	34	130	2.44	1.92	12.10	0.097
	36	140	2.59	2.04	13.55	0.103
PWS 2	30	100	2.21	1.65	4.98	0.088
	31	120	2.52	1.91	6.31	0.100
	32	135	2.75	2.11	7.39	0.109
	33	150	2.98	2.30	8.57	0.118
	35	175	3.36	2.62	10.72	0.133
PWS 3	36	200	3.77	2.96	13.19	0.150
	31	200	3.96	3.06	9.52	0.157
	33	235	4.52	3.53	12.16	0.179
	34	250	4.77	3.73	13.43	0.189
	35	270	5.10	4.00	15.21	0.202
	36	290	5.43	4.27	17.09	0.215
PWS 4	37	320	5.93	4.67	20.11	0.235
	30	225	4.52	3.48	9.34	0.179
	31	245	4.84	3.74	10.62	0.192
	32	260	5.09	3.95	11.64	0.202
	33	290	5.58	4.35	13.84	0.221
	35	320	6.09	4.76	16.26	0.241
PWS 5	36	360	6.77	5.31	19.79	0.268
	32	240	5.10	3.86	12.23	0.202
	34	300	6.15	4.70	17.32	0.244
	35	370	7.36	5.68	24.12	0.292
	38	415	7.86	6.16	24.91	0.297
	40	460	8.28	6.58	24.91	0.297

Airflow based on 30Pa external resistance
Cooling EAT 23°C/50% RH CW 5/11°C
Electrical supply 240V, 1ph, 50Hz
Pressure drop limited to 25kPa

NR figures are taken from the sound power spectra and are based on all positions having a 200mm spigot connection with at least 1 metre of flexible ducting.

Noise Rating · Cooling Performance

Guide NR Figures

The Guide NR figures quoted in the selected data tables are intended to show the levels of noise which may be expected in a typical office environment with the Phantom PWS unit mounted behind a false ceiling.

Since the environment in which the unit is placed can vary the resulting room sound pressure levels can also vary from the Guide NR figures quoted.

Sound Power Levels

The recommended method to calculate the sound pressure level in the occupied space is through the use of measured Sound Power Levels, in a reverberation room to the relevant standards, and the use of theoretical calculations.

Trox can provide professional assistance with these calculation methods.

Laboratory Testing

Trox can provide in-house test facilities to mock-up the proposed arrangement to enhance confidence in the calculated figures and eliminate uncertainty.

Selection Data

Model Size	Guide NR	Air Flow l/s	Total Cooling Kw	Sensible Cooling Kw	Pressure Drop kPa	Fluid Flow l/s
PWS 1	26	70	1.38	1.07	4.32	0.055
	30	85	1.57	1.25	5.37	0.062
	32	100	1.76	1.42	6.71	0.070
	33	115	1.95	1.59	8.17	0.078
	34	130	2.15	1.77	9.56	0.085
	36	140	2.29	1.89	10.83	0.091
PWS 2	30	100	1.98	1.54	4.50	0.078
	31	120	2.23	1.77	5.10	0.089
	32	135	2.43	1.95	5.86	0.096
	33	150	2.62	2.12	6.78	0.104
	35	175	2.96	2.42	8.44	0.117
PWS 3	36	200	3.31	2.72	10.37	0.131
	31	200	3.47	2.81	7.49	0.138
	33	235	3.95	3.23	9.48	0.157
	34	250	4.17	3.42	10.54	0.166
	35	270	4.47	3.67	11.87	0.177
PWS 4	36	290	4.76	3.92	13.36	0.189
	37	320	5.22	4.31	15.86	0.207
	30	225	3.95	3.19	7.29	0.157
	31	245	4.23	3.43	8.27	0.168
	32	260	4.44	3.61	9.02	0.176
PWS 5	33	290	4.86	3.98	10.69	0.193
	35	320	5.31	4.36	12.65	0.211
	36	360	5.92	4.87	15.39	0.235
	32	240	4.47	3.55	9.62	0.178
PWS 5	34	300	5.40	4.33	13.54	0.214
	35	370	6.49	5.24	19.19	0.258
	38	415	7.19	5.82	23.07	0.285
	40	460	7.72	6.32	24.97	0.298

Airflow based on 30Pa external resistance
Cooling EAT 23°C/50% RH CW 6/12°C
Electrical supply 240V, 1ph, 50Hz
Pressure drop limited to 25kPa

NR figures are taken from the sound power spectra and are based on all positions having a 200mm spigot connection with at least 1 metre of flexible ducting.

Cooling Performance

Selection Data

Model Size	Guide NR	Air Flow l/s	Total Cooling Kw	Sensible Cooling Kw	Pressure Drop kPa	Fluid Flow l/s
PWS 1	26	70	1.23	1.00	3.45	0.049
	30	85	1.39	1.16	4.32	0.055
	32	100	1.55	1.31	5.26	0.062
	33	115	1.71	1.46	6.32	0.068
	34	130	1.89	1.62	7.52	0.075
	36	140	2.00	1.72	8.39	0.079
PWS 2	30	100	1.75	1.43	3.21	0.069
	31	120	1.97	1.64	3.98	0.078
	32	135	2.13	1.79	4.59	0.084
	33	150	2.29	1.94	5.27	0.091
	35	175	2.58	2.21	6.54	0.102
	36	200	2.88	2.48	8.00	0.114
PWS 3	31	200	3.01	2.56	5.72	0.120
	33	235	3.42	2.93	7.24	0.136
	34	250	3.61	3.10	7.99	0.143
	35	270	3.87	3.33	9.06	0.153
	36	290	4.13	3.56	10.21	0.164
	37	320	4.52	3.91	12.11	0.180
PWS 4	30	225	3.42	2.90	5.55	0.136
	31	245	3.65	3.11	6.26	0.145
	32	260	3.83	3.27	6.83	0.152
	33	290	4.19	3.60	8.07	0.166
	35	320	4.57	3.94	9.50	0.182
	36	360	5.11	4.41	11.66	0.203
PWS 5	32	240	3.86	3.23	7.26	0.153
	34	300	4.65	3.93	10.25	0.185
	35	370	5.63	4.77	14.60	0.224
	38	415	6.27	5.33	17.80	0.249
	40	460	6.90	5.87	21.28	0.274

Airflow based on 30Pa external resistance
Cooling EAT 23°C/50% RH CW 7/13°C
Electrical supply 240V, 1ph, 50Hz

NR figures are taken from the sound power spectra and are based on all positions having a 200mm spigot connection with at least 1 metre of flexible ducting.

Cooling Performance

Selection Data

Model Size	Guide NR	Air Flow l/s	Total Cooling Kw	Sensible Cooling Kw	Pressure Drop kPa	Fluid Flow l/s
PWS 1	26	70	1.08	0.92	2.74	0.043
	30	85	1.22	1.06	3.41	0.049
	32	100	1.36	1.20	4.13	0.054
	33	115	1.50	1.33	4.95	0.060
	34	130	1.65	1.50	1.47	0.066
	36	140	1.75	1.56	6.54	0.070
PWS 2	30	100	1.54	1.32	2.52	0.061
	31	120	1.72	1.50	3.11	0.068
	32	135	1.86	1.63	3.58	0.074
	33	150	2.00	1.77	4.09	0.080
	35	175	2.24	1.99	5.05	0.089
	36	200	2.50	2.23	6.15	0.099
PWS 3	31	200	2.62	2.32	4.40	0.104
	33	235	2.96	2.64	5.53	0.118
	34	250	3.12	2.79	6.07	0.124
	35	270	3.33	2.98	6.87	0.132
	36	290	3.56	3.19	7.74	0.141
	37	320	3.90	3.50	9.18	0.155
PWS 4	30	225	2.97	2.63	4.24	0.118
	31	245	3.16	2.81	4.77	0.125
	32	260	3.30	2.94	5.18	0.131
	33	290	3.61	3.23	6.09	0.143
	35	320	3.92	3.51	7.12	0.156
	36	360	4.38	3.93	8.73	0.174
PWS 5	32	240	3.32	2.91	5.45	0.132
	34	300	3.99	3.53	7.67	0.158
	35	370	4.83	4.28	10.96	0.192
	38	415	5.40	4.79	13.46	0.215
	40	460	5.97	5.30	16.22	0.237

Airflow based on 30Pa external resistance
Cooling EAT 23°C/50% RH CW 8/14°C
Electrical supply 240V, 1ph, 50Hz

NR figures are taken from the sound power spectra and are based on all positions having a 200mm spigot connection with at least 1 metre of flexible ducting.

Cooling Performance

Selection Data

Model Size	Guide NR	Air Flow l/s	Total Cooling Kw	Sensible Cooling Kw	Pressure Drop kPa	Fluid Flow l/s
PWS 1	26	70	0.90	0.82	2.69	0.043
	30	85	1.03	0.95	3.44	0.049
	32	100	1.16	1.07	4.27	0.055
	33	115	1.29	1.19	5.20	0.062
	34	130	1.43	1.32	6.25	0.068
	36	140	1.52	1.41	7.00	0.073
PWS 2	30	100	1.28	1.17	2.49	0.061
	31	120	1.45	1.34	3.15	0.069
	32	135	1.58	1.46	3.69	0.075
	33	150	1.72	1.59	4.28	0.082
	35	175	1.94	1.80	5.38	0.093
	36	200	2.18	2.02	6.65	0.104
PWS 3	31	200	2.25	2.08	4.65	0.108
	33	235	2.58	2.39	5.97	0.123
	34	250	2.73	2.53	6.60	0.130
	35	270	2.93	2.72	7.52	0.140
	36	290	3.13	2.90	8.52	0.149
	37	320	3.44	3.19	10.13	0.164
PWS 4	30	225	2.55	2.36	4.48	0.122
	31	245	2.74	2.54	5.10	0.131
	32	260	2.88	2.67	5.59	0.137
	33	290	3.16	2.93	6.67	0.151
	35	320	3.47	3.22	7.89	0.165
	36	360	3.88	3.60	9.73	0.185
PWS 5	32	240	2.84	2.62	5.71	0.136
	34	300	3.46	3.20	8.20	0.165
	35	370	4.21	3.90	11.80	0.201
	38	415	4.70	4.35	14.48	0.224
	40	460	5.18	4.80	12.84	0.247

Airflow based on 30Pa external resistance
Cooling EAT 23°C/50% RH CW 10/15°C
Electrical supply 240V, 1ph, 50Hz

NR figures are taken from the sound power spectra and are based on all positions having a 200mm spigot connection with at least 1 metre of flexible ducting.

Heating Performance

Selection Data

Model Size	Guide NR	Air Flow l/s	Heating Kw	Pressure Drop kPa	Fluid Flow l/s
PWS 1	26	70	0.50	0.06	0.006
	30	85	0.53	0.07	0.006
	32	100	0.56	0.08	0.007
	33	115	0.58	0.08	0.007
	34	130	0.61	0.09	0.007
	36	140	0.62	0.09	0.008
PWS 2	30	100	0.77	0.18	0.009
	31	120	0.84	0.21	0.010
	32	135	0.90	0.24	0.011
	33	150	0.97	0.28	0.012
	35	175	1.12	0.36	0.014
	36	200	1.35	0.51	0.016
PWS 3	31	200	0.95	0.06	0.012
	33	235	0.99	0.07	0.012
	34	250	1.01	0.07	0.012
	35	270	1.03	0.07	0.012
	36	290	1.05	0.08	0.013
	37	320	1.07	0.08	0.013
PWS 4	30	225	1.16	0.10	0.014
	31	245	1.19	0.11	0.014
	32	260	1.21	0.11	0.015
	33	290	1.24	0.12	0.015
	35	320	1.28	0.12	0.015
	36	360	1.32	0.13	0.016
PWS 5	32	240	1.27	0.13	0.015
	34	300	1.34	0.15	0.016
	35	370	1.48	0.17	0.018
	38	415	1.59	0.20	0.019
	40	460	1.72	0.23	0.021

Airflow based on 30Pa external resistance
 Heating EAT 21°C LPHW 60/40°C
 Electrical supply 240V, 1ph, 50Hz

NR figures are taken from the sound power spectra and are based on all positions having a 200mm spigot connection with at least 1 metre of flexible ducting.

Heating Performance

Selection Data

Model Size	Guide NR	Air Flow l/s	Heating Kw	Pressure Drop kPa	Fluid Flow l/s
PWS 1	26	70	0.77	0.12	0.009
	30	85	0.93	0.16	0.011
	32	100	1.10	0.24	0.013
	33	115	1.26	0.30	0.015
	34	130	1.43	0.38	0.017
	36	140	1.54	0.44	0.018
PWS 2	30	100	1.10	0.28	0.013
	31	120	1.32	0.40	0.016
	32	135	1.48	0.51	0.018
	33	150	1.65	0.60	0.020
	35	175	1.92	0.83	0.023
	36	200	2.20	1.05	0.026
PWS 3	31	200	2.20	0.25	0.026
	33	235	2.59	0.35	0.031
	34	250	2.75	0.40	0.033
	35	270	2.97	0.45	0.035
	36	290	3.19	0.53	0.038
	37	320	3.52	0.63	0.042
PWS 4	30	225	2.48	0.36	0.030
	31	245	2.70	0.42	0.032
	32	260	2.86	0.48	0.034
	33	290	3.19	0.59	0.038
	35	320	3.52	0.70	0.042
	36	360	3.96	0.89	0.047
PWS 5	32	240	2.64	0.43	0.031
	34	300	3.30	0.65	0.039
	35	370	4.07	0.98	0.048
	38	415	4.57	1.22	0.054
	40	460	5.07	1.49	0.060

Airflow based on 30Pa external resistance
 Heating EAT 21°C LPHW 75/55°C
 Electrical supply 240V, 1ph, 50Hz
 Air Off Coil limited to 30°C

NR figures are taken from the sound power spectra and are based on all positions having a 200mm spigot connection with at least 1 metre of flexible ducting.

Heating Performance

Selection Data

Model Size	Guide NR	Air Flow l/s	Heating Kw	Pressure Drop kPa	Fluid Flow l/s
PWS 1	26	70	0.77	0.32	0.017
	30	85	0.93	0.46	0.020
	32	100	1.10	0.65	0.024
	33	115	1.26	0.82	0.027
	34	130	1.43	1.05	0.031
	36	140	1.54	1.19	0.033
PWS 2	30	100	1.10	0.78	0.024
	31	120	1.32	1.11	0.029
	32	135	1.48	1.38	0.032
	33	150	1.65	1.69	0.036
	35	175	1.92	2.24	0.042
	36	200	2.20	2.91	0.048
PWS 3	31	200	2.20	0.74	0.048
	33	235	2.59	1.01	0.056
	34	250	2.75	1.12	0.060
	35	270	2.97	1.30	0.064
	36	290	3.19	1.49	0.069
	37	320	3.52	1.80	0.076
PWS 4	30	225	2.48	1.02	0.054
	31	245	2.70	1.21	0.058
	32	260	2.86	1.35	0.062
	33	290	3.19	1.65	0.069
	35	320	3.52	1.99	0.076
	36	360	3.96	2.51	0.086
PWS 5	32	240	2.64	1.21	0.057
	34	300	3.30	1.84	0.071
	35	370	4.07	2.76	0.088
	38	415	4.57	3.46	0.099
	40	460	5.07	4.18	0.110

Airflow based on 30Pa external resistance
 Heating EAT 21°C LPHW 82/71°C
 Electrical supply 240V, 1ph, 50Hz
 Air Off Coil limited to 30°C

NR figures are taken from the sound power spectra and are based on all positions having a 200mm spigot connection with at least 1 metre of flexible ducting.

Order Details

Specification Text

Fan coil unit in a compact construction for horizontal installation in false ceiling void.
 Consisting of casing with thermal and acoustic insulation, air filter, double inlet fan, cooling/heating coils for 2 or 4 pipe systems, condensation tray, multi-outlet spigots suitable for discharge of air through slot diffusers, square or swirl diffusers. (e.g. Trox types VSD, ADT, SDW).

Suitable for taking inlet air from ceiling void or ducted from space, also provision of controlled amount of fresh air (e.g. control by Trox type RN regulator).

Materials

Galvanised sheet steel casing with thermal/acoustic lining. Cooling/heating coils with galvanised steel frame, copper pipes aluminum fins. Galvanised sheet steel, externally insulated condensate drain pan, fan with galvanised steel casing.

Order Code

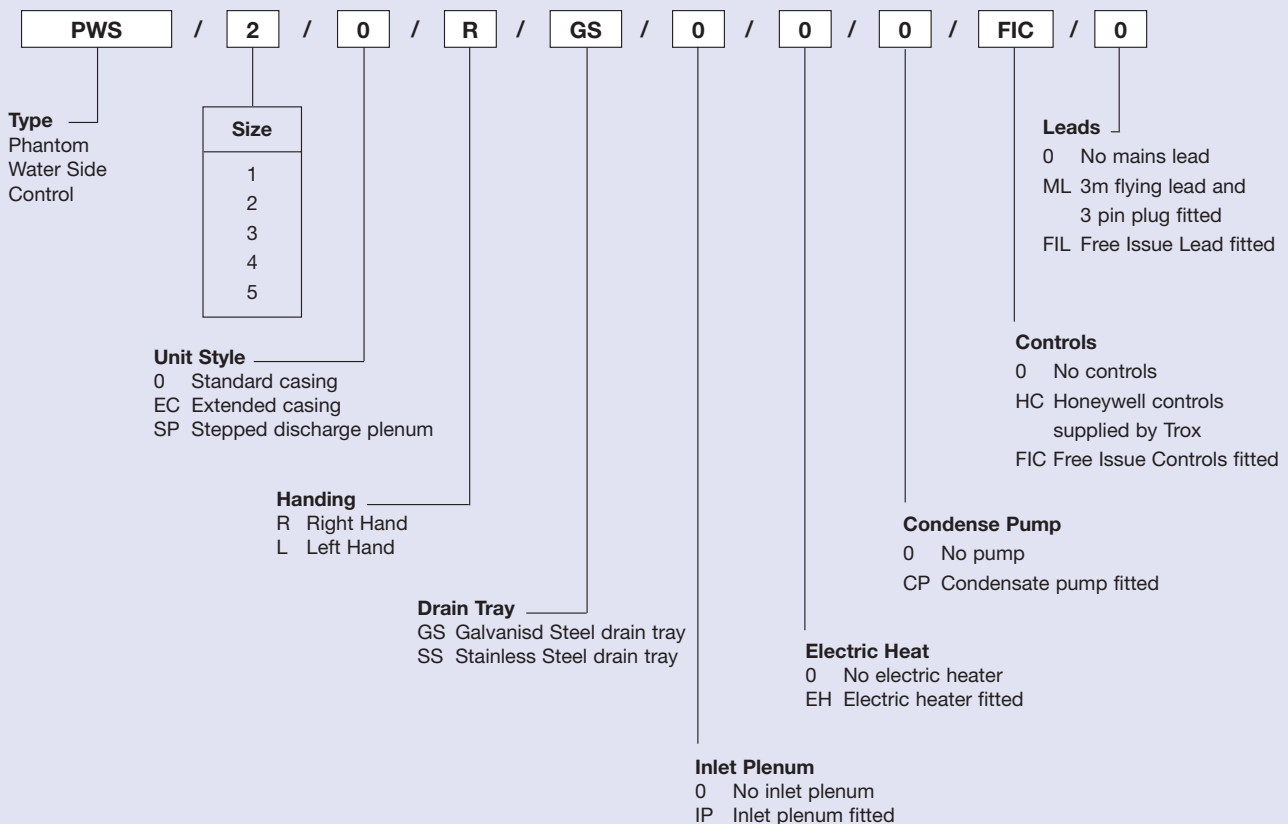

Order Example

Make : TROX
 Type : PWS/2/0/R/GS/0/0/0/FIC/0