

Flexible Plenum Boxes

Type FLEXTRO
For ceiling diffusers

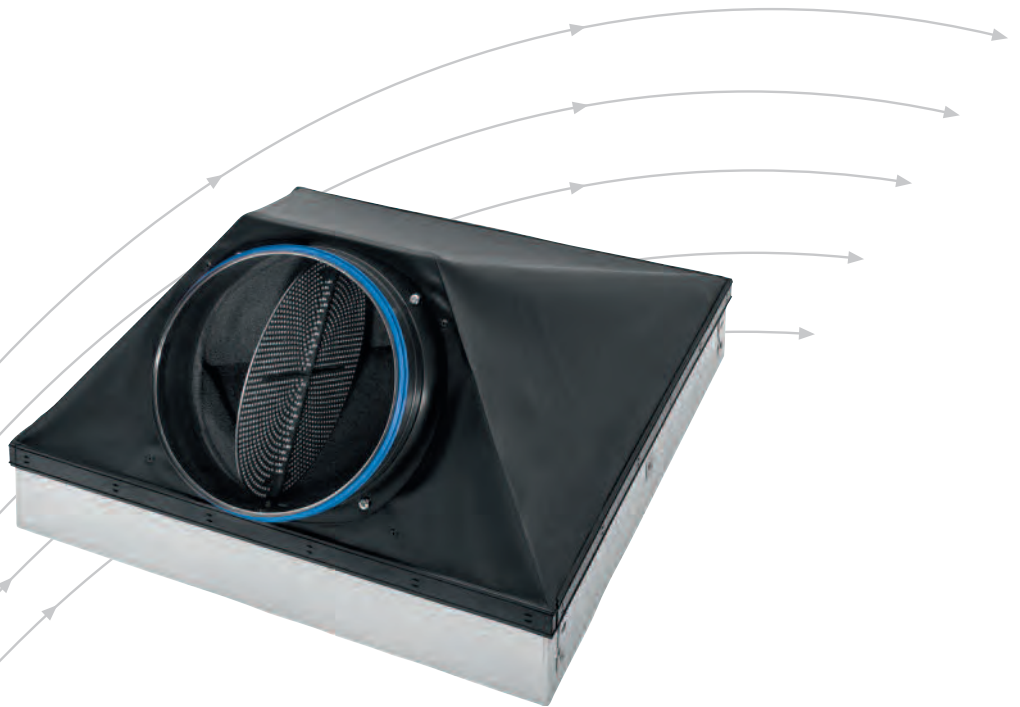

TROX[®] TECHNIK

The art of handling air

Contents · Description

Description	2	Diffusers	6
Innovation	3	Nomenclature · Quick selection	7
Construction · Dimensions	4	Order details	8
Installation · Flow rate balancing	5		

Type FLEXTRO

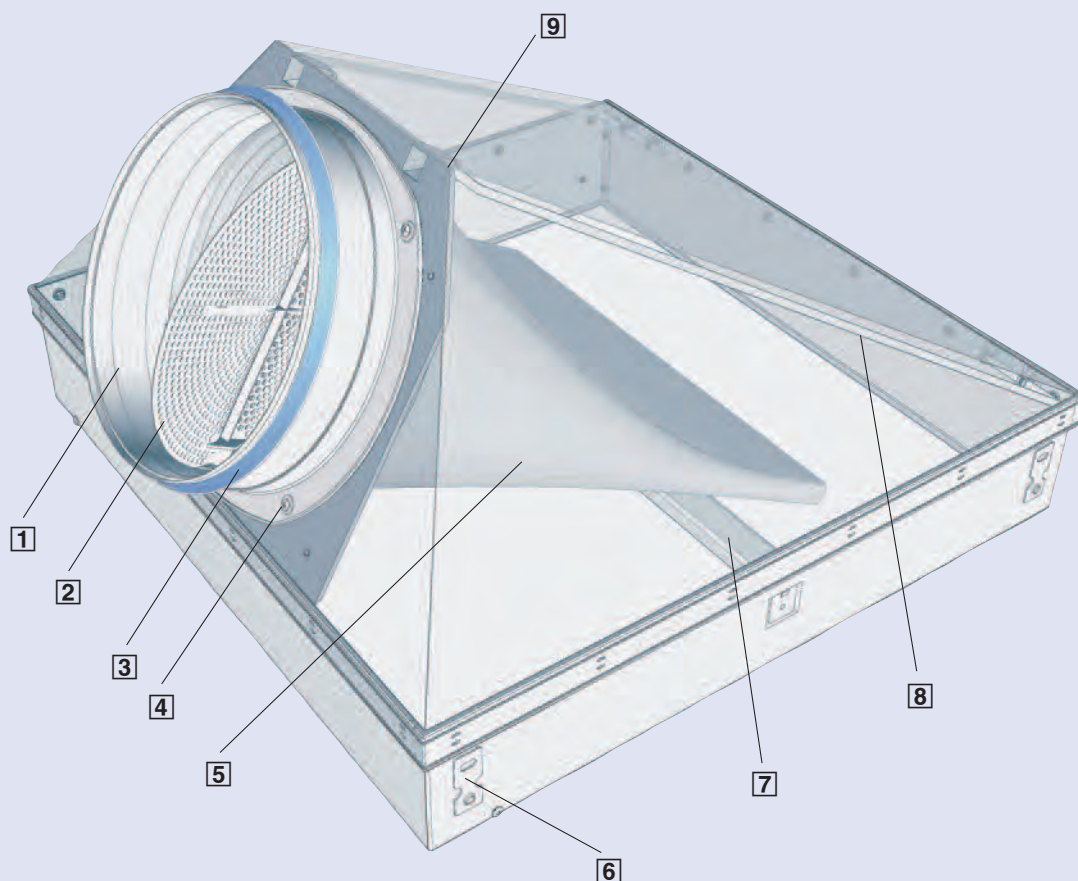

- 1 Spigot
- 2 Damper for flow rate balancing
- 3 Double lip seal
- 4 Fixing screw
- 5 Air distribution element (only for supply air)

- 6 Hanging bracket
- 7 Crossbar for fixing the diffuser face
- 8 Metal angled support rod
- 9 Clip fix for metal angled support rod

The flexible plenum boxes of the FLEXTRO type are characterised by their innovative design, which combines aerodynamic function and easy handling in the best possible way. What is more, they provide a high degree of architectural flexibility as they can be fitted with a wide variety of different ceiling diffusers and hence be integrated into any type of ceiling system.

The plenum box folds flat for transport and storage and takes up very little space.

Erecting the plenum box is easy and it is ready for installation in no time at all.

The unique shape of the plenum box and a newly developed air distribution element provide a particularly efficient air discharge and a uniform air flow through the ceiling diffuser. As a consequence, the air is evenly distributed in the room.

A spigot with double lip seal provides a low leakage connection of the plenum box to the ducting, and a damper for flow rate balancing simplifies commissioning.

Advantages

- Up to 50 % less weight; approximately 60 % less transport and storage space required
- Easy to transport; easy and quick to erect for installation
- Newly developed air distribution element to ensure a uniform air flow through a supply air diffuser
- Acoustically optimised damper blade for flow rate balancing
- Spigot with double lip seal

As delivered



Comparatively larger conventional plenum box

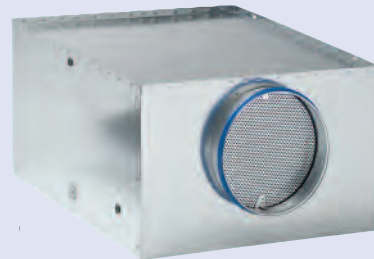

Ready for installation



FLEXTRO with ceiling diffuser (VDW shown)



Construction · Dimensions

Characteristics

- For circular or square ceiling diffusers
- For supply or extract air
- For installation into suspended ceilings
- Suitable for all types of ceilings
- Spigot at 30° angle
- Damper blade for flow rate balancing, can be set in 15° intervals between 0 and 90°

Construction features

- Spigot, nominal size 250 mm, with double lip seal suitable for circular ducts in compliance with EN 1506 or EN 13180
- Four hanging brackets to suspend the unit using wires, threaded rods, or metal hangers; this has to be undertaken by the customer
- Height when folded flat (as delivered) 145 mm (-R) or 110 mm (-Q)
- For 600 and 625 mm ceiling grids
- Weight approx. 4 kg

Flexible plenum box		Order code
Diffuser face	Application	
Circular	Supply air	-R-Z
	Extract air	-R-A
Square	Supply air	-Q-Z
	Extract air	-Q-A

Materials

- Frame made of galvanised sheet steel, metal angled support rod and crossbar made of galvanised steel
- Spigot, spigot mounting plate and damper blade made of ABS plastic, UL 94, flame retardant (V0)
- The flexible walls of the plenum box are made from polyester fabric in compliance with DIN 4102, fire rating class B1
- Air distribution element made of synthetic fibre

Dimensions

FLEXTRO-R...

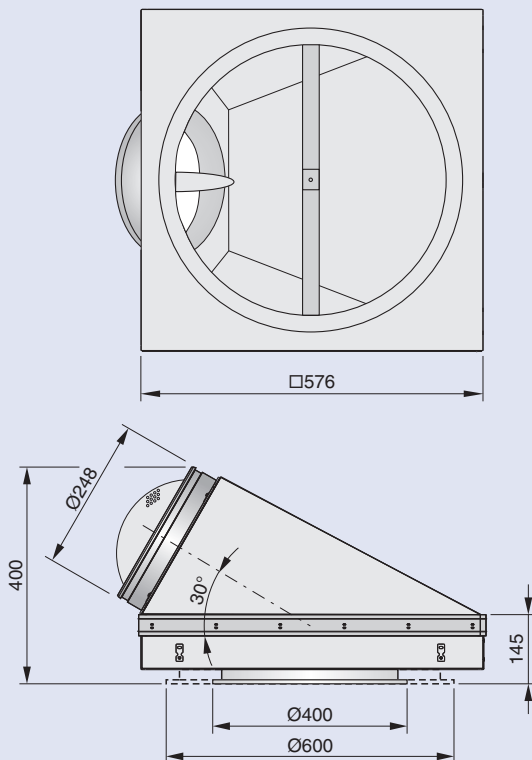

FLEXTRO-Q...

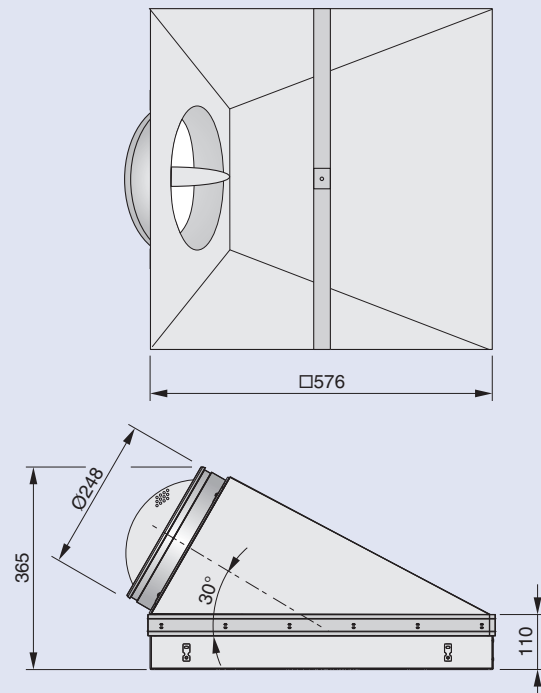

As delivered

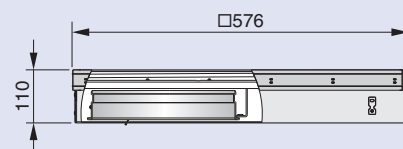
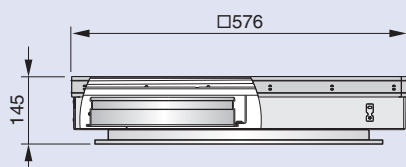

Figure shows FLEXTRO-R.../600

Installation · Flow rate balancing

- Installation of the plenum box, connection to the duct, and provision of connecting and fixing materials have to be undertaken by the customer.

The diffuser must only be installed and connected by trained expert personnel.

All legal regulations for site work must be complied with.

The plenum box has four hanging brackets for fixing it to the ceiling slab. Only fixing systems which have been approved by the building inspectorate should be used.

To connect the plenum box to the ventilation system, flexible ducts are recommended. The double lip seal ensures a tight connection. Additional sealing material is not required.

Installation into grid ceilings

The flexible plenum box is suspended from the ceiling slab. The ceiling grid is suspended independent of the diffuser face/plenum box. The diffuser face can be installed after the false ceiling has been completed.

Installation into plasterboard ceilings

The flexible plenum box is suspended from the ceiling slab. The plasterboard ceiling tile must be independently suspended. The diffuser face can be either flush with the tile or surface mounted (as shown below).

Installation into T-bar ceilings

The flexible plenum box is suspended from the ceiling slab. Once the false ceiling has been completed, the diffuser face can be installed below the T profile.

Flow rate balancing

When several diffusers are connected to just one volume flow controller it may become necessary to balance the volume flow rates. To do so, the face plate can be removed to access the damper; the damper blade can then be set in 15° intervals between 0 and 90°.

Installation into suspended ceiling systems

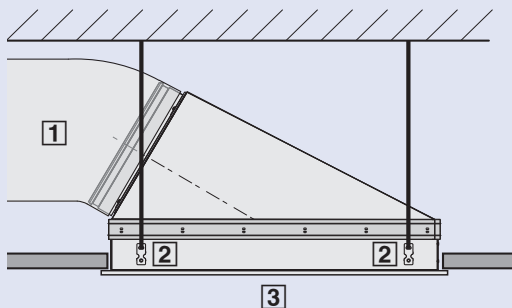

Grid ceiling

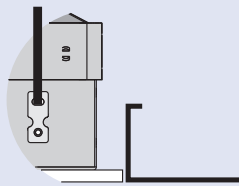

Plasterboard ceiling

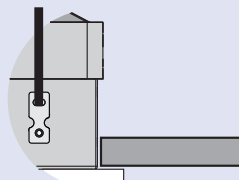

T-bar ceiling

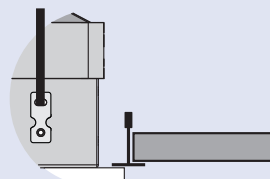

- 1 Duct
- 2 Hanging bracket
- 3 Diffuser face

Flow rate balancing

Open, 0°

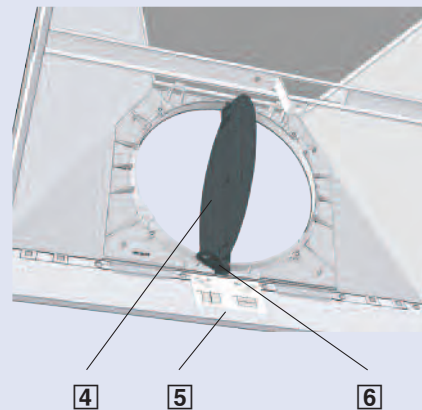

Closed, 90°

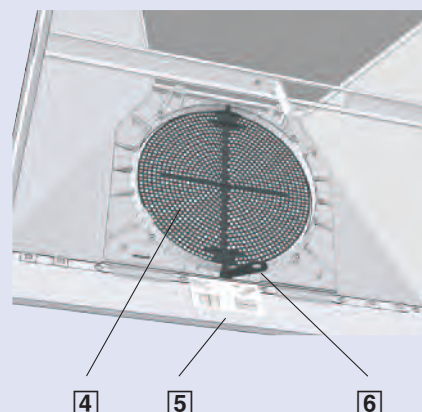

- 4 Damper blade
- 5 Sticker explaining the damper blade position
- 6 Setting lever

Diffusers

The FLEXTRO plenum box can be fitted with a wide variety of different ceiling diffusers by means of a central fixing screw. Customers can choose between square and circular swirl diffusers.

Aerodynamic and acoustic data for the diffusers shown here are the result of measurements. Other diffusers may be used (aerodynamic and acoustic data not available).









More detailed descriptions and technical data can be found in the leaflets for the different diffuser types.

FLEXTRO-R



FLEXTRO-Q



Suitable diffusers for FLEXTRO					
FLEXTRO - R	AIRNAMIC R 400L R 400H	FD-R 600 FD-R 625		VDW 600x24 VDW 625x24	
	AIRNAMIC R 600	TDF-R 600 TDF-R 625		TDV-R 600 TDV-R 625	
FLEXTRO - Q	AIRNAMIC Q 600 Q 625	FD-Q 600 FD-Q 625		VDW 600x24 VDW 625x24	
	DLQ 600 DLQ 625 ADLQ 600 ADLQ 625	TDF-Q 600 TDF-Q 625		TDV-Q 600 TDV-Q 625	

Nomenclature · Quick selection

Nomenclature

- \dot{V} in l/s and m³/h : Volume flow rate
- \dot{V}_{\min} in l/s and m³/h : Minimum volume flow rate
- Δp_t in Pa : Total differential pressure
- L_{PA} in dB(A) : A-weighted sound pressure level
- L_{WA} in dB(A) : A-weighted sound power level
- L_{WNC} : NC rating of sound power level
($L_{WNC} \approx L_{WA} - 6$ dB)

The noise levels quoted are the dB (A) rating of the sound power level L_{WA} . A typical room correction of 5 dB/oct. results in a sound pressure level of $L_{PA} \approx L_{WA} - 5$ dB.

All sound power levels are based on 1 pW.

All noise levels were determined in a reverberation chamber according to EN ISO 5315.

Technical data based on an air density of 1.2 kg/m³.

Using quick selection for sizing ceiling diffusers will rapidly provide optimum results. It ensures compliance with normally acceptable aerodynamic and acoustic limits.

- Pressure differential
- Sound power level

For a more detailed selection and design of ceiling diffusers refer to the Easy Product Finder design programme on our homepage.

Supply air																											
Diffuser type		Volume flow rate and total differential pressure for a given sound power level																Correction values for different damper blade positions									
		Damper blade open																									
		$L_{WA} = 30$ dB(A)				$L_{WA} = 35$ dB(A)				$L_{WA} = 40$ dB(A)				$L_{WA} = 45$ dB(A)				45°		90°							
		\dot{V}_{\min}		\dot{V}		Δp_t		\dot{V}		Δp_t		\dot{V}		Δp_t		\dot{V}		Δp_t		$\Delta p_t \times$		$L_{WA} +$					
l/s		m ³ /h		Pa		l/s		m ³ /h		Pa		l/s		m ³ /h		Pa		l/s		m ³ /h		Pa		dB		dB	
AIRNOMIC	R 400L	40	145	75	270	9	85	305	13	105	380	18	125	450	26	145	520	37	1.3	2.1	0	0					
	R 400H	70	250	105	380	16	125	450	22	145	520	31	175	630	44	205	740	62	1.5	2.4	0	1					
	R 600	115	415	175	630	23	210	755	33	245	880	46	290	1045	64	345	1240	89	1.9	3.4	6	10					
	Q 600 Q 625	125	450	205	740	29	240	865	39	280	1010	53	325	1170	71	375	1350	97	1.9	4.2	8	16					
VDW 600 × 24 VDW 625 × 24		85	305	155	560	25	185	665	35	215	775	47	250	900	65	295	1060	89	1.6	2.8	2	7					
FD 600 · FD 625		60	215	120	430	19	140	505	27	165	595	38	200	720	53	235	845	75	1.5	2.4	1	2					
TDF 600 TDF 625		120	430	150	540	26	175	630	36	210	755	51	245	880	71	290	1045	100	1.5	2.6	2	5					
TDV 600 TDV 625		130	470	175	630	30	200	720	40	235	845	54	275	990	73	315	1135	99	1.6	3.0	5	8					
DLQ / ADLQ 600 DLQ / ADLQ 625		220	790	220	790	32	255	920	45	300	1080	62	355	1280	87	420	1510	121	2.1	4.1	11	16					
Extract air																											
AIRNOMIC	R 400L			110	395	16	130	470	22	155	560	32	185	665	45	225	810	65	1.1	2.3	0	6					
	R 400H			125	450	18	145	520	25	175	630	35	205	740	49	240	865	68	1.3	2.6	1	9					
	R 600			165	595	13	190	685	18	225	810	25	260	935	34	305	1100	46	1.6	4.8	5	16					
	Q 600 Q 625			170	610	11	200	720	16	240	865	22	280	1010	30	330	1190	42	1.9	5.8	6	16					
	VDW 600 × 24 VDW 625 × 24				190	685	12	220	790	16	255	920	22	300	1080	30	345	1240	40	2.0	6.5	7	20				
	FD 600 · FD 625				130	470	15	150	540	20	175	630	27	205	740	37	240	865	51	1.6	3.1	4	12				
	TDF 600 TDF 625				125	450	15	145	520	20	170	610	28	200	720	39	235	845	54	1.2	3.0	0	12				
	TDV 600 TDV 625				155	560	16	180	650	21	210	755	28	240	865	38	280	1010	51	1.4	3.8	3	16				
DLQ / ADLQ 600 DLQ / ADLQ 625				185	665	9	220	790	13	260	935	18	305	1100	25	360	1295	35	2.3	7.8	7	22					

Order details



Specification text

Flexible plenum boxes of type FLEXTRO to be combined with circular or square ceiling diffusers for supply or extract air. Excellent aerodynamic and acoustic performance as a result of the unique construction and a special air distribution element (supply air). The plenum box can be folded flat for transport and storage.

Special characteristics

- Newly developed air distribution element to ensure a uniform air flow through a supply air diffuser
- Acoustically optimised damper blade for flow rate balancing
- Spigot with double lip seal
- Low weight, and low volume when folded flat for transport and storage

Consists of a steel frame with hanging brackets, flexible walls, a connecting spigot, and a crossbar for fixing the diffuser face. The connecting spigot is equipped with an acoustically optimised damper blade for flow rate balancing. Plenum boxes for supply air contain an air distribution element.

Ø250 mm spigot with double lip seal suitable for circular ducts in compliance with EN 1506 or EN 13180.

Available FLEXTRO variants:

- FLEXTRO-R-Z
Plenum box for circular supply air diffusers
- FLEXTRO-R-A
Plenum box for circular extract air diffusers
- FLEXTRO-Q-Z
Plenum box for square supply air diffusers
- FLEXTRO-Q-A
Plenum box for square extract air diffusers

Materials

Frame made of galvanised sheet steel, metal angled support rod and crossbar made of galvanised steel. Spigot, spigot mounting plate and damper blade made of ABS plastic, UL 94, flame retardant (V0). The flexible walls of the plenum box are made of coated polyester fabric in compliance with DIN 4102, fire rating class B1. Air distribution element made of synthetic fibre.

Order code

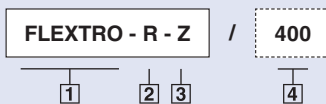

1 Type

2 Diffuser face

- R Circular
- Q Square

3 Ventilation system

- Z Supply air
- A Extract air

4 Nominal size

- Specify only for circular diffuser faces
- 400
 - 600

Order example

Make: TROX
Type: FLEXTRO-R-Z / 400