

Swirl Diffuser

Type VDW

recommended for room heights from approx. 2.60 ... 4.00 m

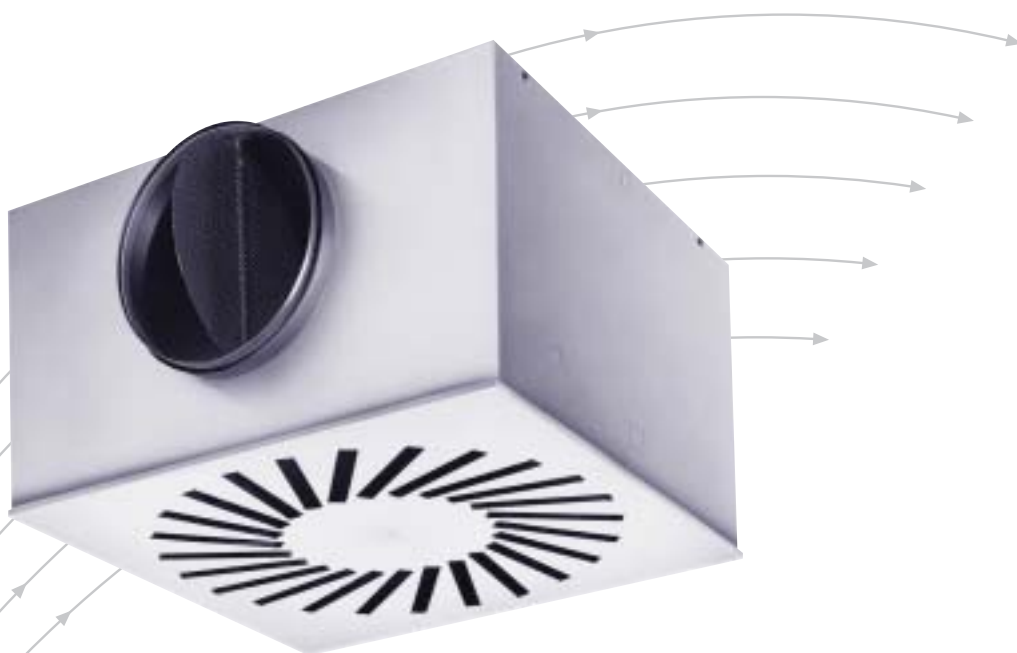

TROX[®] TECHNİK

TROX GmbH

Telephone +49/28 45/2 02-0

Heinrich-Trox-Platz

Telefax +49/28 45/2 02-2 65

D-47504 Neukirchen-Vluyn

e-mail trox@trox.de

www.troxtechnik.com

Contents · Description

Description	2
Discharge Characteristics	3
Constructions · Dimensions	4
Materials	6
Installation · Assembly	6
Nomenclature	7
Preliminary Selection	7
Spectral Data	7
Acoustic Data	8
Aerodynamic Data	11
Order Details	18

In addition to the existing range of TROX swirl diffusers, the type VDW swirl diffuser with manual adjustment has been developed.

This enables the direction of discharge to be altered on site to cater for changes in room layout or partitions. Due to the rotary swirling motion of the air discharge, induction of room air occurs very quickly, resulting in a rapid decay of supply air velocity and temperature differential. Air change rates of 30 per hour can be achieved with supply air temperature differentials of +10K to -10K.

The diffuser can be supplied with either circular or square face plate depending on architectural requirements, additionally with white or black air control blades. Air is supplied via top or side entry plenum boxes.

The type VDW can be used for either supply or extract air application. For supply air, special control elements are required. These are not necessary for use in the extract air mode.

Construction VDW - R, Size 500 x 24
with black air control blades



Construction VDW - R, Size 600 x 48
with black air control blades



Construction VDW - Q, Size 600 x 24
with white air control blades



Construction VDW - Q, Size 825 x 72
with black air control blades

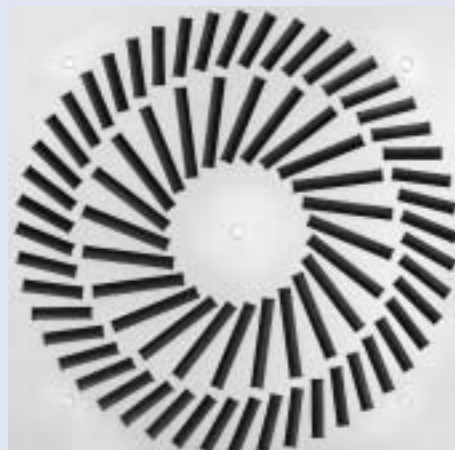

Discharge Characteristics

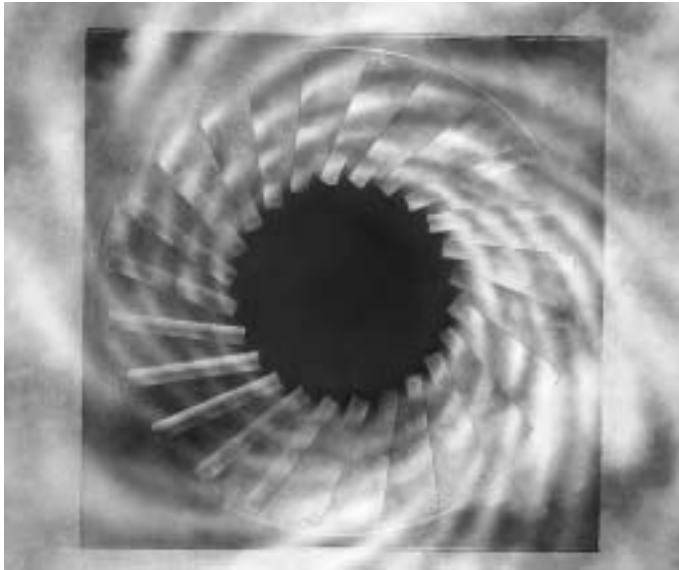

The manual adjustment of the VDW swirl diffuser means that architectural changes, for instance relocation of lightweight partition walls, can be catered for by changes in discharge pattern. Directions of discharge can be altered by adjustment of the control blade settings.

For sizes 300 x 8, 400 x 16, 500 x 24, 600 x 24 and 625 x 24 the air control blades are set as standard to external swirl and for sizes 600 x 48, 625 x 54 and 825 x 72 the air control blades of the outer blade ring are set to external swirl and those of the inner blade ring to internal swirl.

The flow visualisation opposite shows the air discharge characteristics, control blades set for internal swirl.

Positions of air control blades

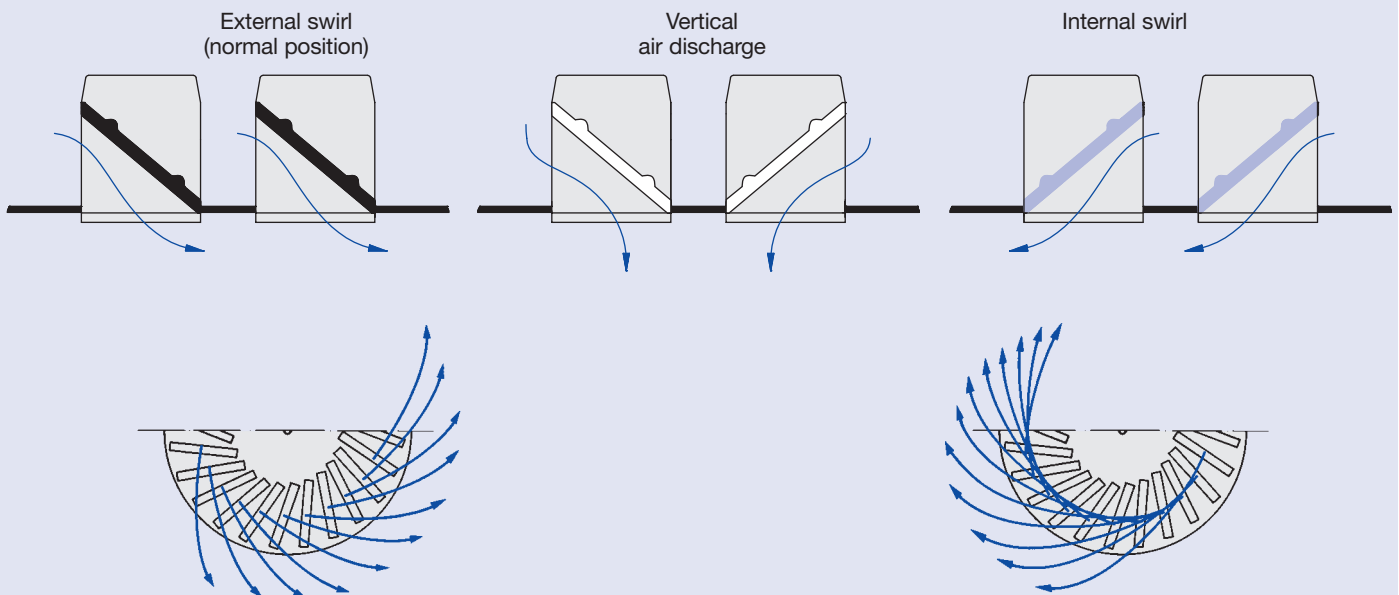

Discharge Characteristics for sizes 300x8, 400x16, 500x24, 600x24 and 625x24

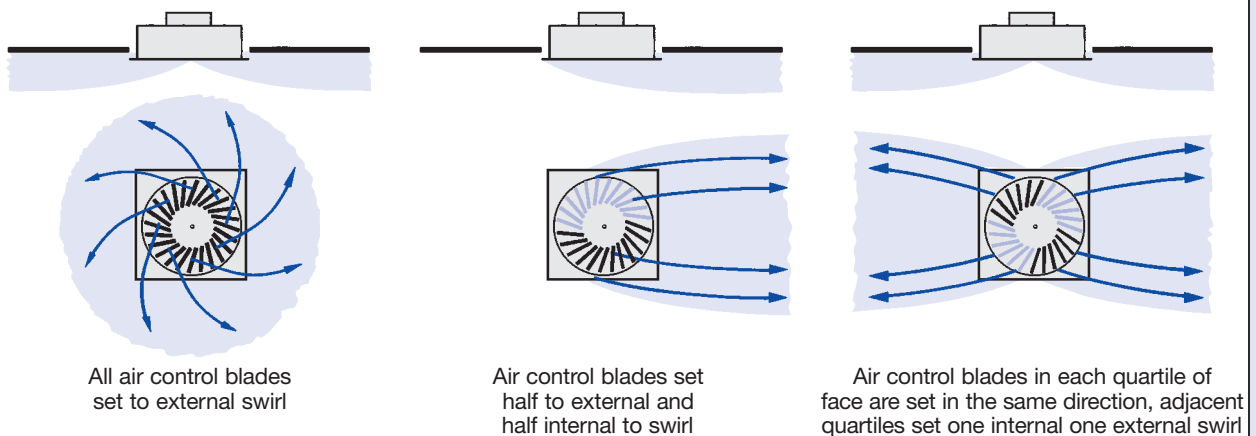

Constructions · Dimensions

Constructions

Adjustable swirl diffusers type VDW are supplied in the sizes listed below:

Size 300 x 8 with 8 air control blades,
 Size 400 x 16 with 16 air control blades,
 Size 500 x 24 with 24 air control blades,
 Size 600 x 24 with 24 air control blades,
 Size 600 x 48 with 48 air control blades,
 Size 625 x 24 with 24 air control blades,
 Size 625 x 54 with 54 air control blades,
 Size 825 x 72 with 72 air control blades,

The face plate can be circular or square to suit the architectural requirements, except for sizes 625 x 54 and 825 x 72, which are only supplied in square format.

The removeable face plate is held in the plenum box with a centre screw fixing. The head of the screw is covered with a decorative cap.

The plenum box is available with side or top entry spigot, with volume control damper and/or lip seal on request.

If a circular diffuser face is ordered fitted with a side entry plenum box, a 35 mm extension piece is fitted to the plenum, as shown on Page 5 (VDW-R-H).

For simple adjustment of the volume flow, on request the plenum box can be provided with a test connection for measurement of a reference pressure and a volume control damper operated by sheathed cables. The characteristic curve of pressure reading versus volume flow rate for each size of plenum box is supplied.

Note: If a larger size side entry plenum is fitted to a diffuser face, this should be considered in relation to performance (lower noise levels and pressure drop).

Size 300 x 8

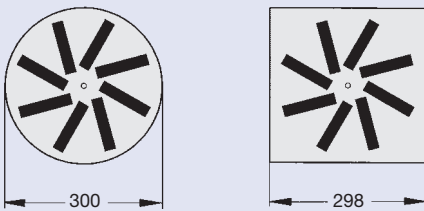

Size 400 x 16

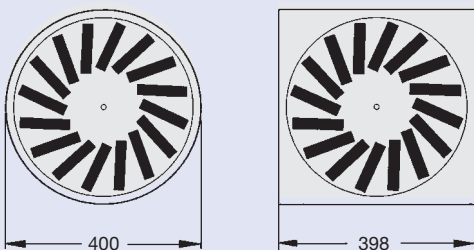

Size 500 x 24

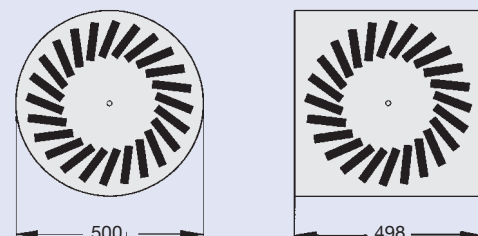

Size 600 x 24/Size 625 x 24

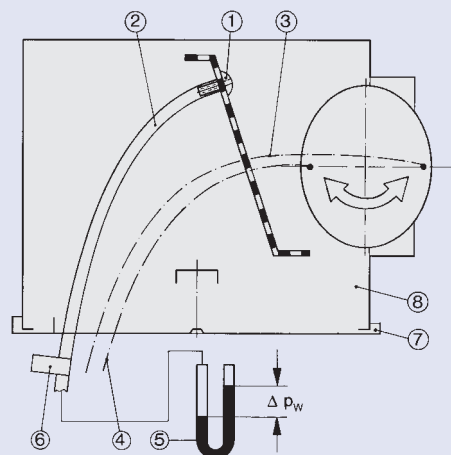
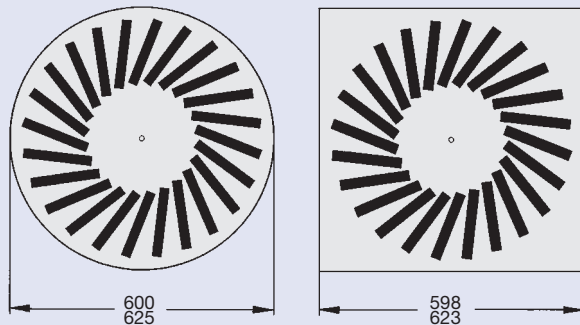

- | | |
|--------------------------------------|----------------------|
| ① Test nipple | ⑤ Inclined manometer |
| ② Plastic tube | ⑥ Code |
| ③ White sheathed cable damper open | ⑦ Diffuser face |
| ④ Green sheathed cable damper closed | ⑧ Plenum box |

Constructions · Dimensions

Size	B	D	H ₁	H ₂	P	K	AK Code for ¹⁾ Diffuser Face	
							Circular	Square
300 x 8	280	158	200	250	278	290	AK 013	AK 001
400 x 16	364	198	200	295	362	372	AK 014	AK 002
500 x 24	462	198	200	295	460	476	AK 015	AK 003
600 x 24	559	248	200	345	557	567	AK 016	AK 004
600 x 48	580	248	300	345	578	590	AK 017	AK 005
625 x 24	559	248	200	345	557	567	AK 016	AK 004
625 x 54	605	248	300	345	-	615	-	AK 006
825 x 72	796	313	300	410	-	806	-	AK 007

1) Only valid for VDW-...-H!

Size 600 x 48

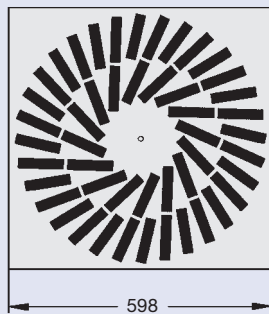
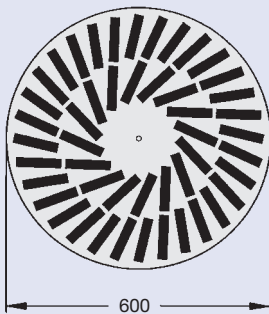

Size 625 x 54

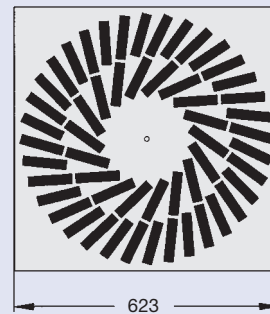

Size 825 x 72

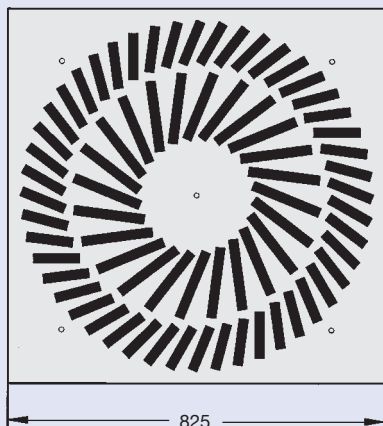

Plenum Box

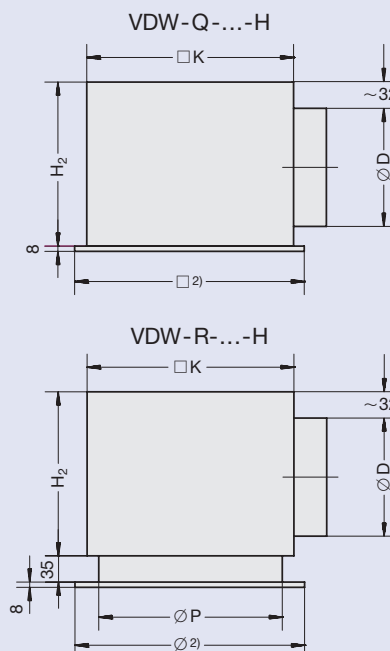

VDW-...-V

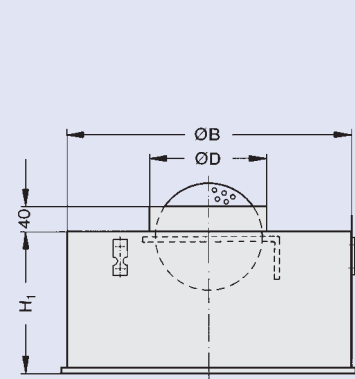

2) Overall face dimension

Materials · Installation · Assembly

Materials

The face plate is in galvanised sheet steel. The surfaces are pre-treated and powder coated white (RAL 9010).

The control blades are made from Polystyrol (PS 476L), with black (similar to RAL 9005) as standard or white (similar to RAL 9010) on request.

The plenum box is made from galvanised sheet steel, the rubber lip seal.

Installation

All sizes are suitable for flush mounting into a ceiling.

If the diffuser is installed below a closed ceiling (i.e. freely suspended) a stable discharge can be achieved if a peripheral collar > 50 mm is provided – available on request.

Assembly

The plenum box is suspended using wires or slotted strips, using the drilled holes in the plenum return edge or hanging brackets when provided. For the side entry plenum box, a self adhesive seal, supplied loose, must be fitted by the client. The diffuser face is fitted to the plenum box by means of centre fix screw locating in cross channel of the plenum box.

Installation Flush to Ceiling

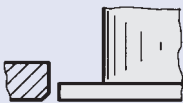

Installation with cut-out in Ceiling

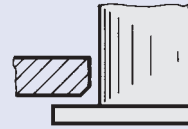

Surface Mounting on Ceiling

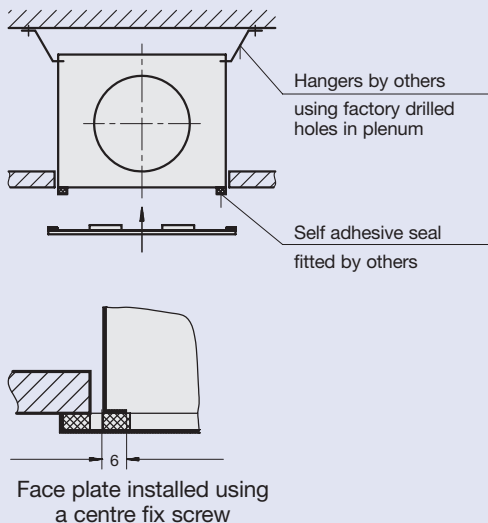

Installation Suspended from Slab

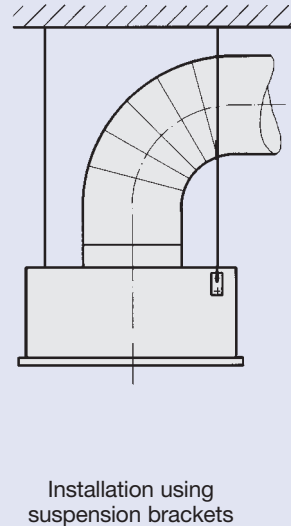

Nomenclature · Preliminary Selection · Spectral Data

Nomenclature

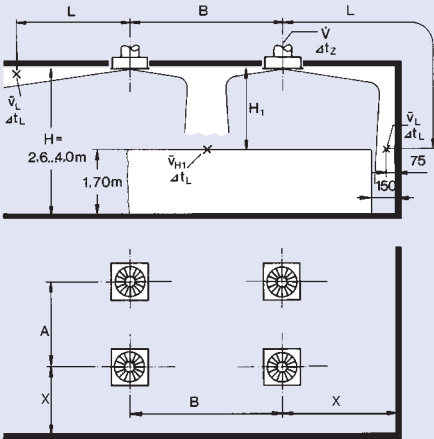

- \dot{V} in l/s: Supply air volume per diffuser
- \dot{V} in m³/h: Supply air volume per diffuser
- A, B in m: Spacing between two diffusers
- X in m: Distance between diffuser centre and wall
- H₁ in m: Distance between ceiling and occupied zone
- \bar{v}_{H1} in m/s: Time average air velocity between two diffusers at distance from ceiling H₁
- L in m: Horizontal + vertical distance (X+H₁) discharge to the wall
- \bar{v}_L in m/s: Time average air velocity at wall
- Δt_z in K: Temperature difference between supply air and room air
- Δt_L in K: Difference between core and room temperature at distance $L = A/2 + H_1$ or $L = B/2 + H_1$ or $L = X + H_1$
- A_{eff} in m²: Effective outlet area
- Δp_t in Pa: Total pressure drop (supply air)
- L_{WA} in dB(A): A-weighted sound power level
- L_{W NC}: NC rating of sound power level
- L_{W NR}: L_{W NR} = L_{W NC} + 1
- L_{pA}, L_{pNC}: A-weighting and NC rating respectively of room sound pressure level
- L_{pA} ≈ L_{WA} - 8 dB
- L_{pNC} ≈ L_{W NC} - 8 dB
- ΔL in dB/Oct.: Relative sound power level with respect to L_{WA}
- L_W in dB/Oct.: Octave band sound power level of regenerated noise L_W = L_{WA} + ΔL

Preliminary Selection (supply air)

Size	\dot{V}_{max}		\dot{V}_{min}		L _{WA max} dB(A)	L _{W NC max} NC	L _{WA min} dB(A)	L _{W NC min.} NC	A _{eff} m ²
	l/s	m ³ /h	l/s	m ³ /h					
300 x 8	70	252	15	54	40	34	< 20	< 20	0.0070
400 x 16	110	396	30	108	40	34	< 20	< 20	0.0140
500 x 24	130	468	40	144	40	34	< 20	< 20	0.0210
600 x 24	190	684	60	216	40	34	< 20	< 20	0.0295
600 x 48	230	828	100	360	40	34	< 20	< 20	0.0390
625 x 24	190	684	60	216	40	34	< 20	< 20	0.0295
625 x 54	235	846	120	432	40	34	< 20	< 20	0.0470
825 x 72	350	1260	155	558	40	34	< 20	< 20	0.0730

Octave band spectrum available on request!

Acoustic Data Type VDW-...-V

Supply air

Correction to diagrams 1, 2 and 3: Volume control damper setting

Size	Damper angle	0°	45°	90°
300 x 8	Δp_t	x 1.0	x 1.2	x 1.8
	L_{WA}/L_{WNC}	-	-	-
400 x 16	Δp_t	x 1.0	x 1.1	x 2.0
	L_{WA}/L_{WNC}	-	-	+ 1
500 x 24	Δp_t	x 1.0	x 1.4	x 2.8
	L_{WA}/L_{WNC}	-	+ 3	+ 6

1 Sound Power Level and Pressure Drop
Size 300x8

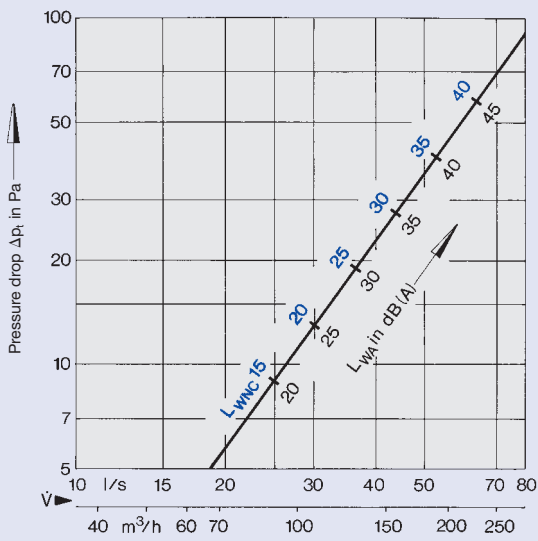

2 Sound Power Level and Pressure Drop
Size 400x16

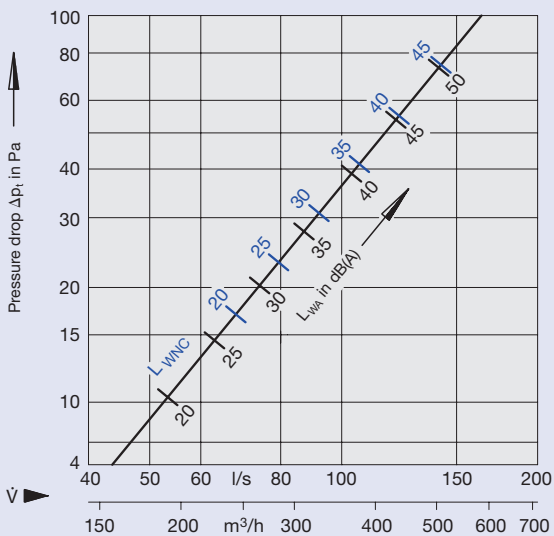

3 Sound Power Level and Pressure Drop
Size 500x24

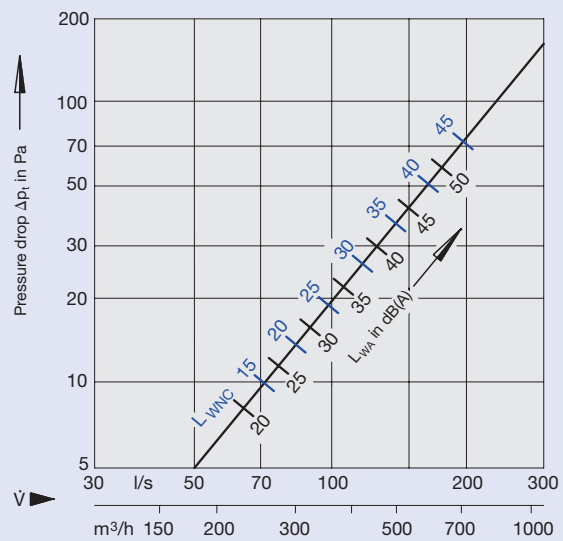

Acoustic Data Type VDW-...-V

Supply air

Correction to diagrams 4 to 7: Volume control damper setting				
Size	Damper angle	0°	45°	90°
600 x 24	Δp_t	x 1.0	x 1.3	x 2.8
	L_{WA} / L_{WNC}	-	+ 3	+ 5
600 x 48	Δp_t	x 1.0	x 1.6	x 3.4
	L_{WA} / L_{WNC}	-	+ 4	+ 9
825 x 72	Δp_t	x 1.0	x 1.3	x 3.3
	L_{WA} / L_{WNC}	-	+ 2	+ 4

4 Sound Power Level and Pressure Drop
Size 600 x 24 and size 625 x 24

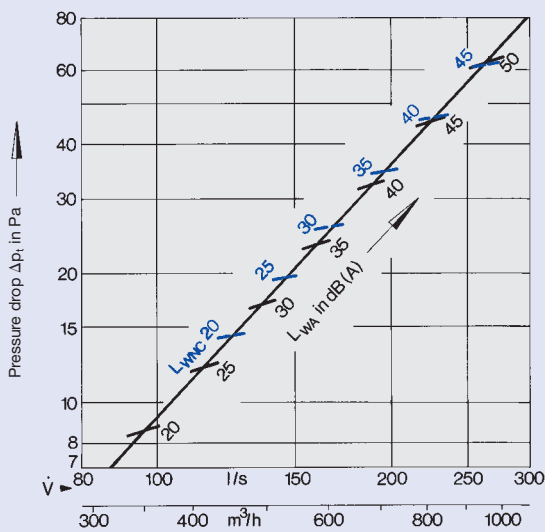

6 Sound Power Level and Pressure Drop
Size 625 x 54

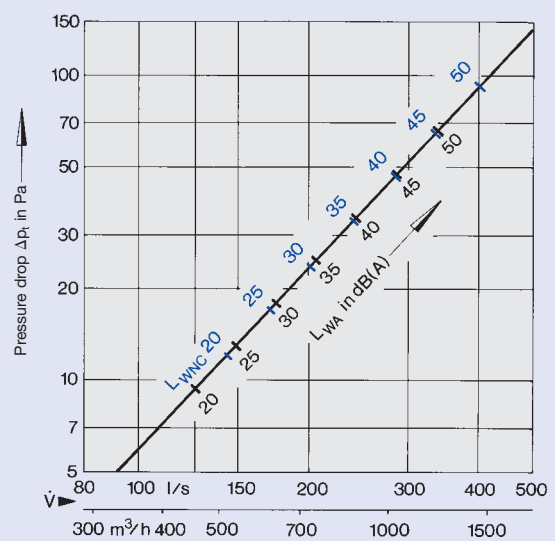

5 Sound Power Level and Pressure Drop
Size 600 x 48

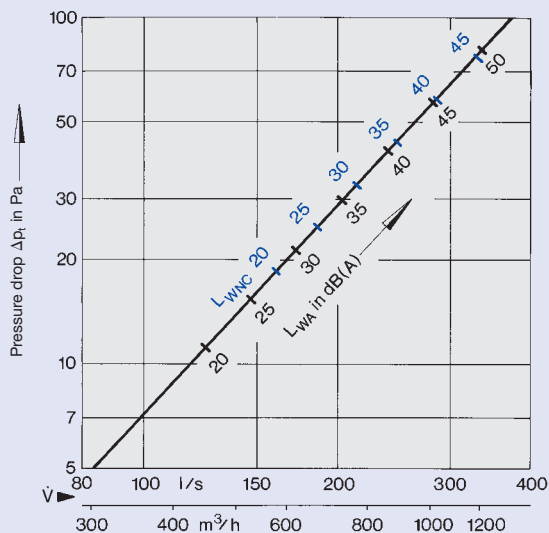

7 Sound Power Level and Pressure Drop
Size 825 x 72

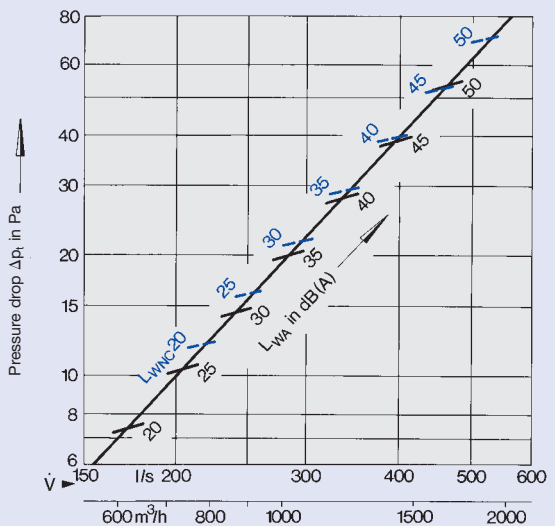

Acoustic Data Type VDW-...-H

Supply air

Correction to diagrams 8 to 10: Volume control damper setting

Size	Damper angle	0°	45°	90°
300 x 8	Δp_t	x 1.0	x 1.3	x 2.2
	L_{WA}/L_{WNC}	-	+ 3	+ 5
400 x 16	Δp_t	x 1.0	x 1.2	x 2.3
	L_{WA}/L_{WNC}	-	+ 1	+ 3
500 x 24	Δp_t	x 1.0	x 1.5	x 3.4
	L_{WA}/L_{WNC}	-	+ 2	+ 3

8 Sound Power Level and Pressure Drop
Size 300 x 8

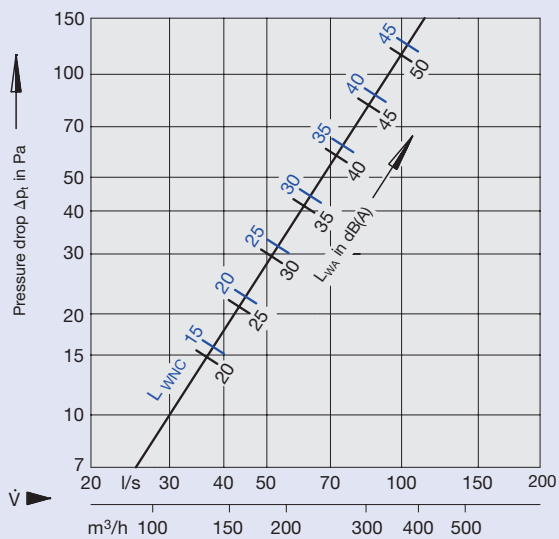

10 Sound Power Level and Pressure Drop
Size 500 x 24

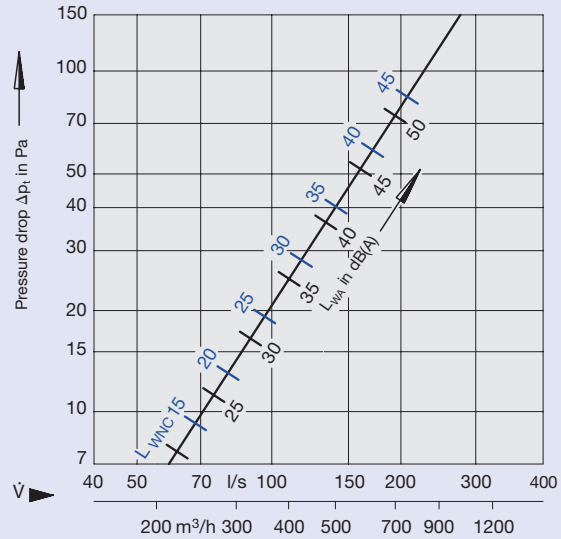

9 Sound Power Level and Pressure Drop
Size 400 x 16

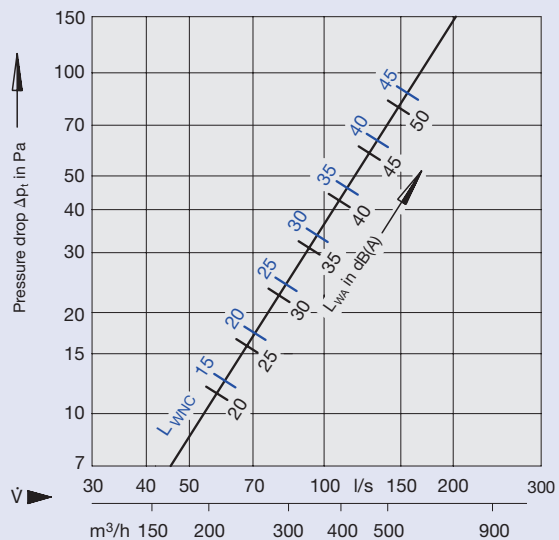

Acoustic Data Type Typ VDW-...-H

Supply air

**Correction to diagrams 11 to 14:
Volume control damper setting**

Size	Damper angle	0°	45°	90°
600 x 24	Δp_t	x 1.0	x 1.5	x 4.0
	L_{WA} / L_{WNC}	-	+ 2	+ 5
625 x 24	Δp_t	x 1.0	x 1.7	x 4.5
	L_{WA} / L_{WNC}	-	+ 4	+ 10
600 x 48	Δp_t	x 1.0	x 1.7	x 5.1
	L_{WA} / L_{WNC}	-	+ 5	+ 10
625 x 54	Δp_t	x 1.0	x 1.5	x 4.7
	L_{WA} / L_{WNC}	-	+ 5	+ 11

11 Sound Power Level and Pressure Drop
Size 600x24 and size 625x24

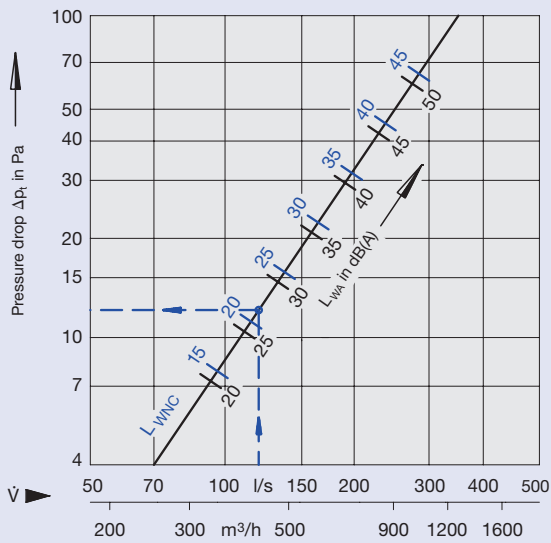

13 Sound Power Level and Pressure Drop
Size 625x54

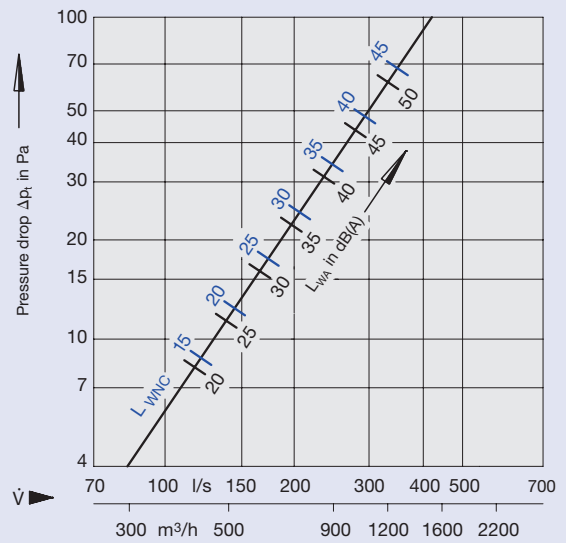

12 Sound Power Level and Pressure Drop
Size 600x48

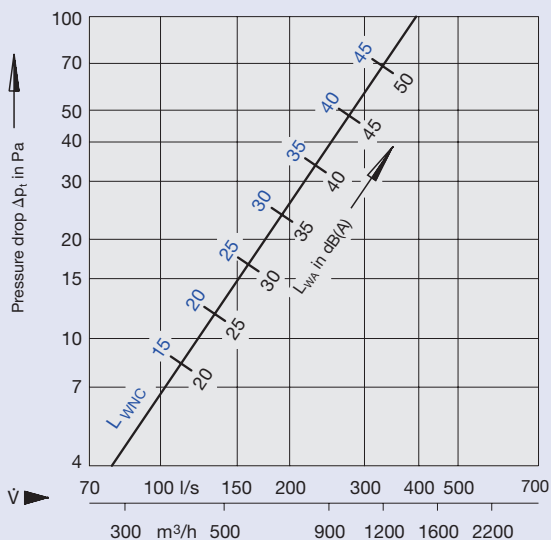

14 Sound Power Level and Pressure Drop
Size 825x72

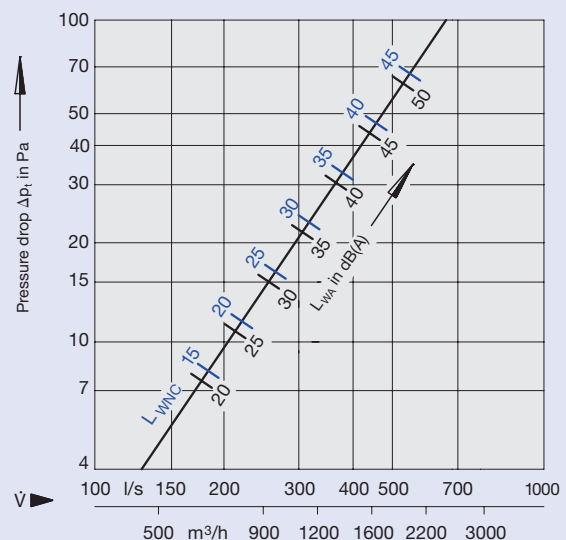

Acoustic Data

Extract air

**Correction to diagrams 15 and 17:
Volume control damper setting**

Size	Damper angle	0°	45°	90°
300 x 8	Δp_t	x 1.0	x 1.5	x 3.0
	L_{WA}/L_{WNC}	-	+7	+9
400 x 16	Δp_t	x 1.0	x 1.8	x 4.1
	L_{WA}/L_{WNC}	-	+4	+9
500 x 24	Δp_t	x 1.0	x 1.8	x 4.1
	L_{WA}/L_{WNC}	-	+3	+9

**Correction to diagrams 16 and 18:
Volume control damper setting**

Size	Damper angle	0°	45°	90°
600 x 24	Δp_t	x 1.0	x 2.0	x 5.6
625 x 24	L_{WA}/L_{WNC}	-	+2	+9
600 x 48	Δp_t	x 1.0	x 2.0	x 5.6
625 x 54	L_{WA}/L_{WNC}	-	+2	+10
825 x 72	Δp_t	x 1.0	x 2.3	x 6.5
	L_{WA}/L_{WNC}	-	+2	+11

15 Sound Power Level and Pressure Drop VDW-...-H

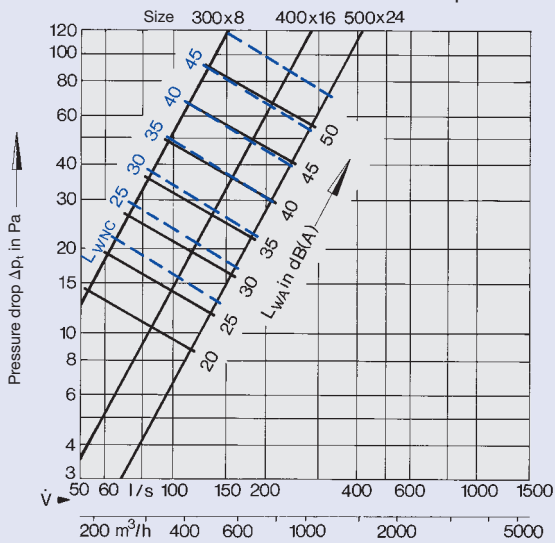

17 Sound Power Level and Pressure Drop VDW-...-V

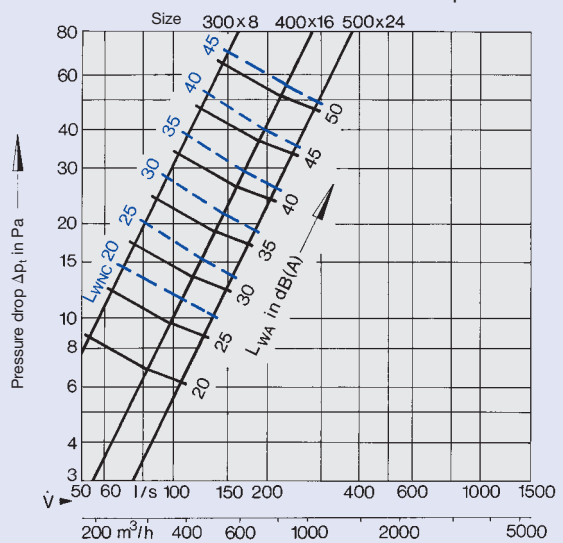

16 Sound Power Level and Pressure Drop VDW-...-H

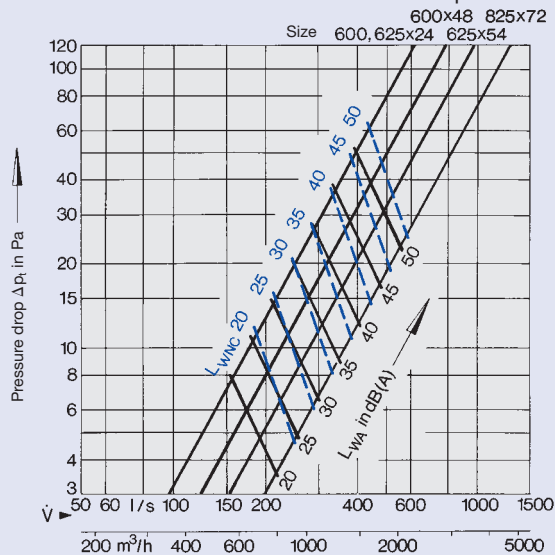

18 Sound Power Level and Pressure Drop VDW-...-V

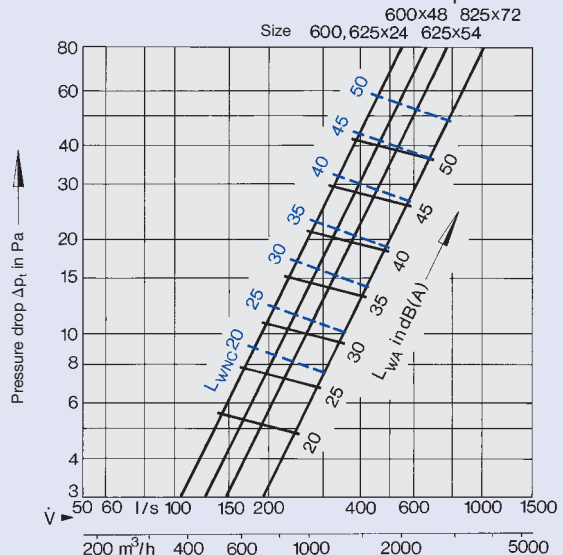

Correction!

For an installation below a continuous ceiling, the values \bar{v}_{H1} , \bar{v}_L , and $\Delta t_L / \Delta t_z$ must be multiplied by a factor of 0.71!

19 Diffuser arrangement:
single row or more than one row if $B > 4.00$ m

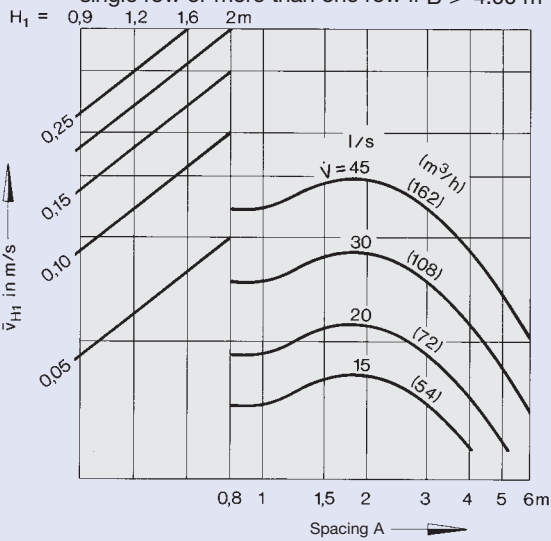

20 Diffuser arrangement:
more than one row if $B = 3.00$ m

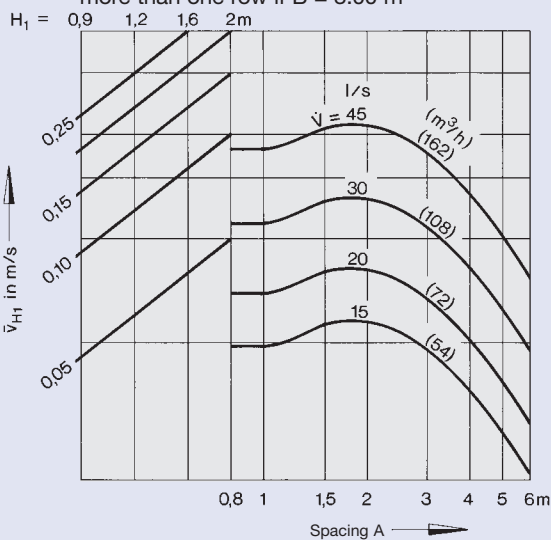

21 Temperature Quotient

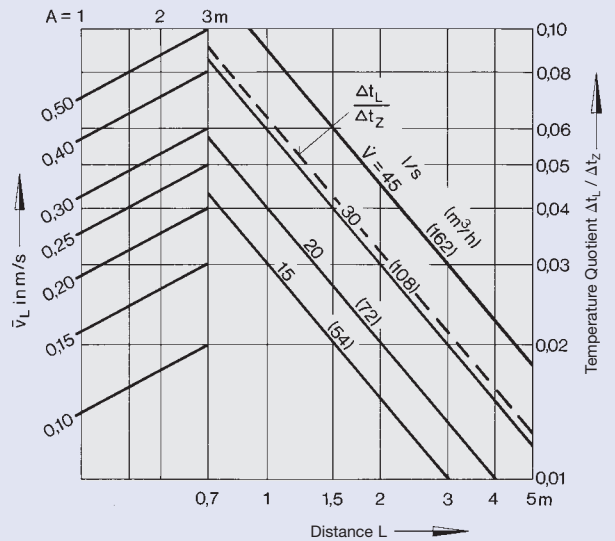

22 Square diffuser

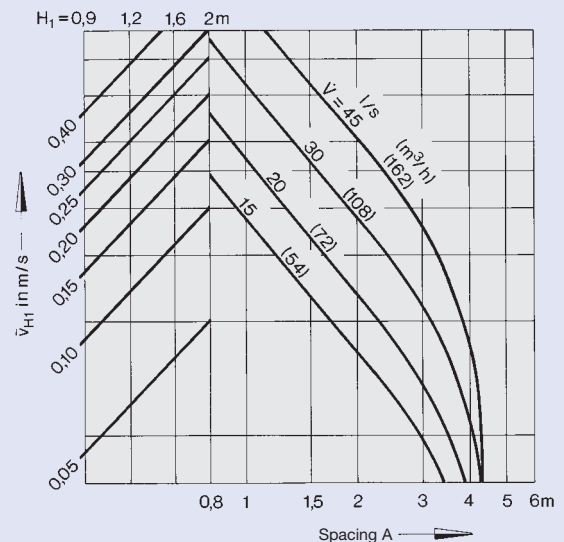

Aerodynamic Data

Size 400 x 16

Correction!

For an installation below a continuous ceiling, the values \bar{v}_{H1} , \bar{v}_L , and $\Delta t_L / \Delta t_z$ must be multiplied by a factor of 0.71!

23 Diffuser arrangement:
single row or more than one row if $B > 4.00$ m
 $H_1 = 0,9 \quad 1,2 \quad 1,6 \quad 2$ m

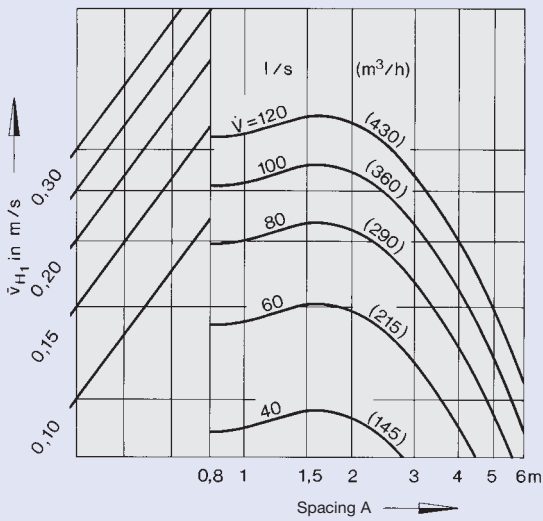

24 Diffuser arrangement:
more than one row if $B = 3.00$ m
 $H_1 = 0,9 \quad 1,2 \quad 1,6 \quad 2$ m

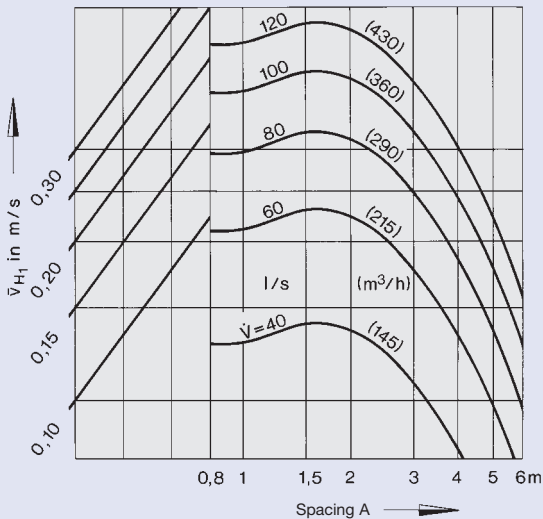

25 Temperature Quotient

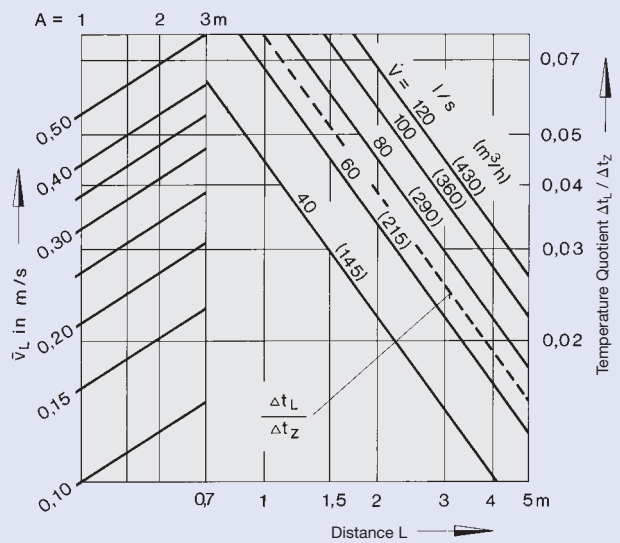

26 Square diffuser

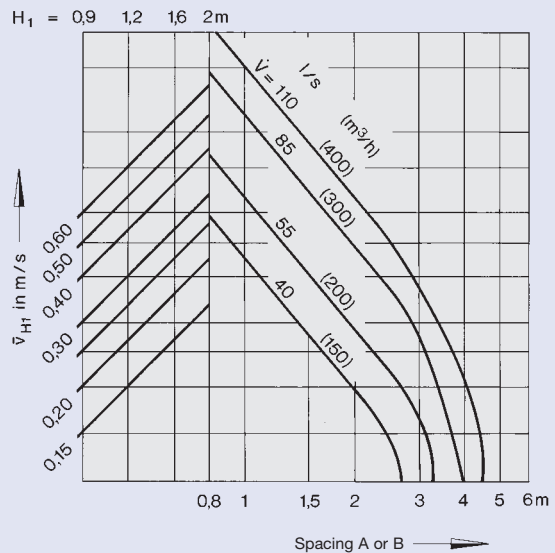

Correction!

For an installation below a continuous ceiling, the values \bar{v}_{H1} , \bar{v}_L , and $\Delta t_L / \Delta t_z$ must be multiplied by a factor of 0.71!

27 Diffuser arrangement:
single row or more than one row if $B > 4.00$ m

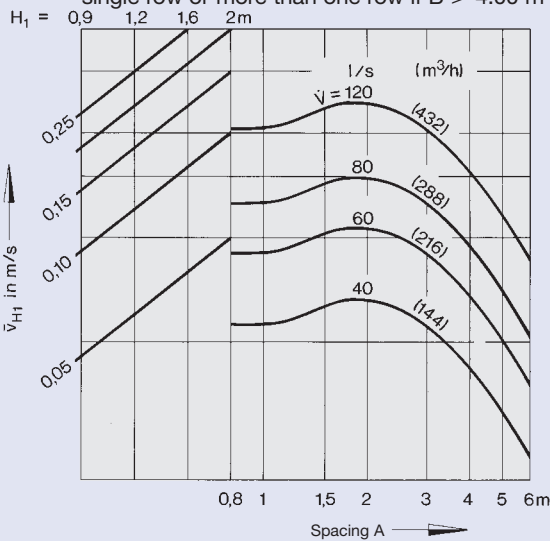

28 Diffuser arrangement:
more than one row if $B = 3.00$ m

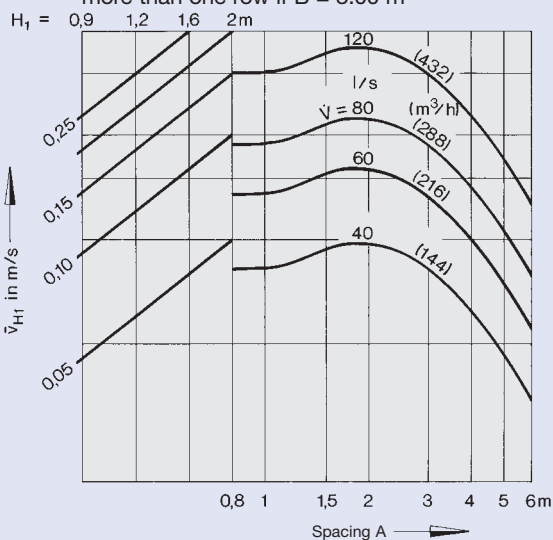

29 Temperature Quotient

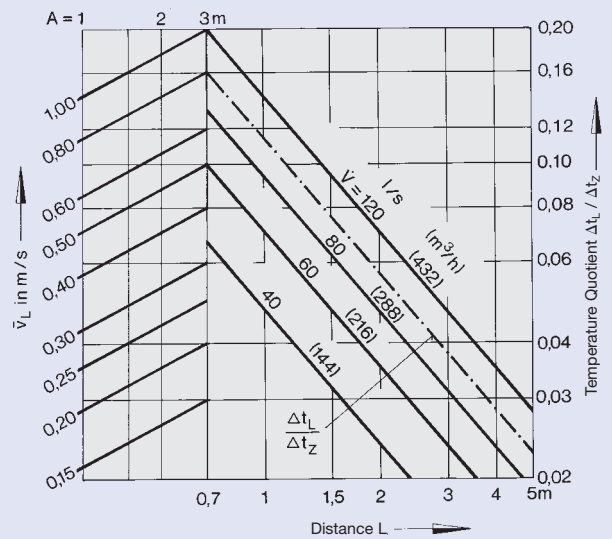

30 Square diffuser

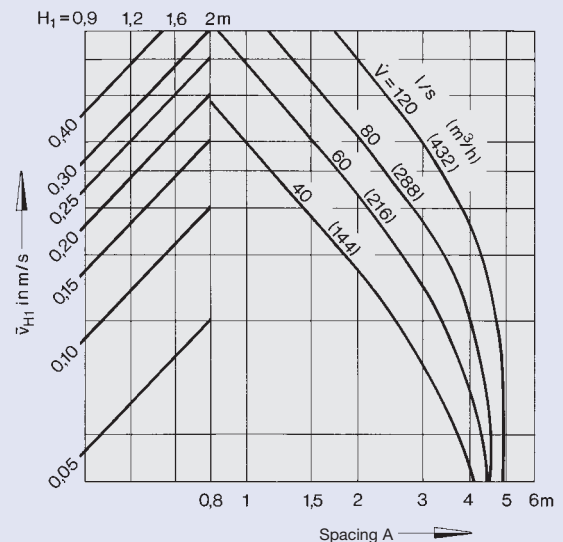

Aerodynamic Data

Size 600 x 48

Example

Data given:

A hall measuring B x L x H = 24 m x 24 m x 3.40 m is to be designed using VDW swirl diffusers for supply air.

Total volume flow rate $\dot{V} = 16000 \text{ l/s}$ (57600 m³/h)

Supply air temperature differential $\Delta t_z = -8 \text{ K}$

Room temperature $t_R = 24^\circ\text{C}$

For structural reasons, no diffuser should be placed closer than 3 m to the external facade.

Requirement: Air velocity \bar{v}_{H1} and \bar{v}_L should not exceed 0.2 m/s. The regenerated noise level of each diffuser is limited to $L_{WA} = 30 \text{ dB(A)}$.

Initial observation:

Since the diffusers have to be arranged at a distance of X = 3 m from the external facade, the remaining area available for installation is 18 m x 18 m.

Consider a distance between rows B = 3.0 m

This results in 7 rows

$$\dot{V} \text{ per row} = \frac{16000 \text{ l/s}}{7} \approx 2280 \text{ l/s}$$

For spacing of diffusers along the rows select A = 1.0 m. This results in 19 diffusers per row.

The volume flow per diffuser then becomes

$$\frac{2280 \text{ l/s}}{19} = 120 \text{ l/s}$$

Correction!

For an installation below a continuous ceiling, the values \bar{v}_{H1} , \bar{v}_L , and $\Delta t_L / \Delta t_z$ must be multiplied by a factor of 0,71!

For adjustment of blade rings for external swirl, the diagram values must be multiplied by 1.25!

31 Diffuser arrangement: single row or more than one row if B > 4.00 m

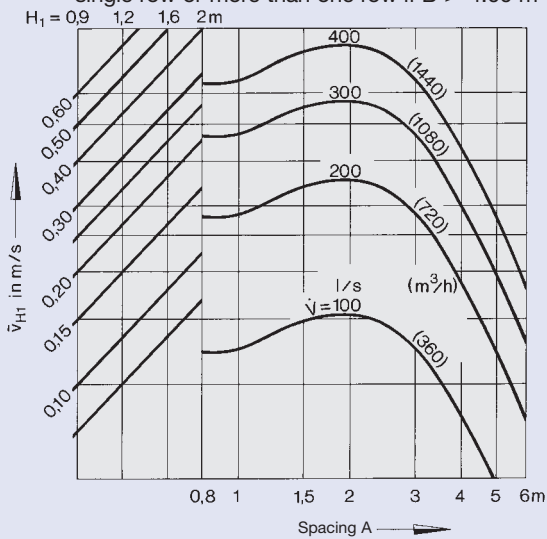

33 Temperature Quotient

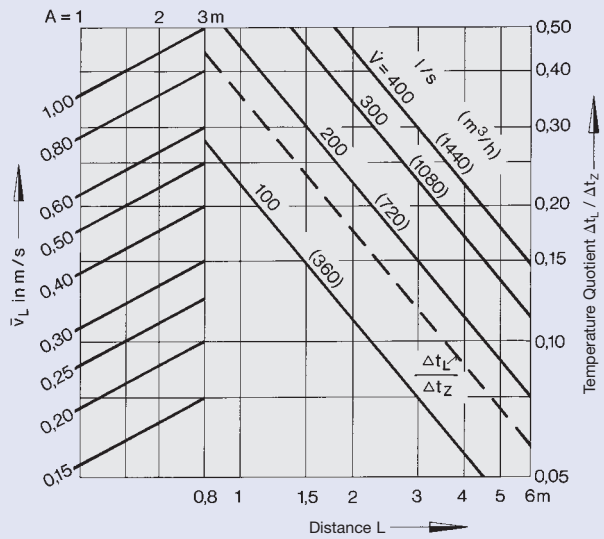

32 Diffuser arrangement: more than one row if B = 3.00 m

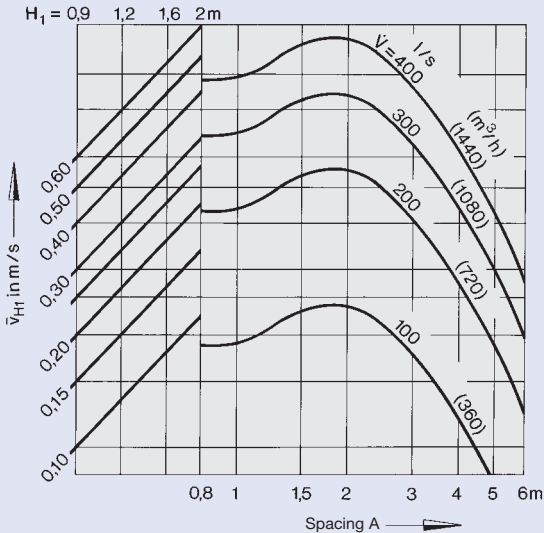

34 Square diffuser

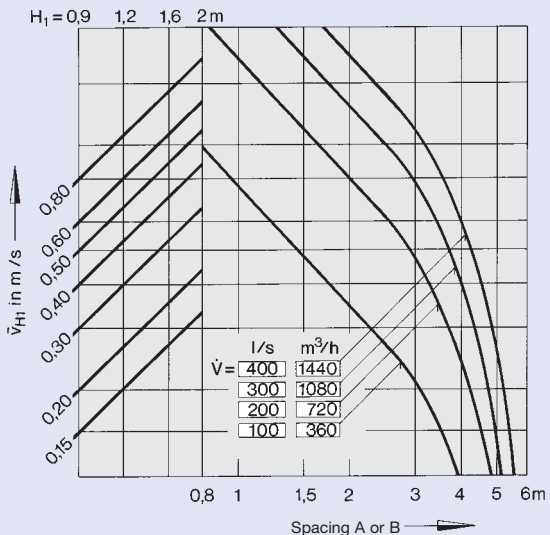

Aerodynamic Data

Sizes 600 x 24 and 625 x 24

Diagram 11: Sound power level and pressure drop
 $L_{WA} = 27 \text{ dB(A)}$ ($L_{WNC} = 21 \text{ NC}$)
 $\Delta p_t = 12 \text{ Pa}$

Result:

133 off VDW - Q - Z - H / 600 x 24

At the required air change rate of 30 per hour, the noise level requirements are met and the limiting air velocities not exceeded.

Diagram 36: Square diffuser: more than one row if $B = 3.00 \text{ m}$

$H_1 = H - 1.70 = 1.70 \text{ m}$
 $\bar{v}_{H1} = 0.17 \text{ m/s}$

Diagram 37: Temperature Quotient between two diffusers

$L = H_1 + A/2 = 2.20 \text{ m}$
 $\Delta t_L / \Delta t_z = 0.05$
 $\Delta t_L = -8 \times 0.05 = -0.4 \text{ K}$
 $L = H_1 + X = 4.70 \text{ m}$ at the wall
 $\bar{v}_L = 0.18 \text{ m/s}$
 $\Delta t_L / \Delta t_z = 0.023$
 $\Delta t_L = -8 \times 0.023 = -0.2 \text{ K}$

Correction!

For an installation below a continuous ceiling, the values \bar{v}_{H1} , \bar{v}_L , and $\Delta t_L / \Delta t_z$ must be multiplied by a factor of 0.71!

35 Diffuser arrangement: single row or more than one row if $B > 4.00 \text{ m}$
 $H_1 = 0.9 \text{ 1.2 1.6 2m}$

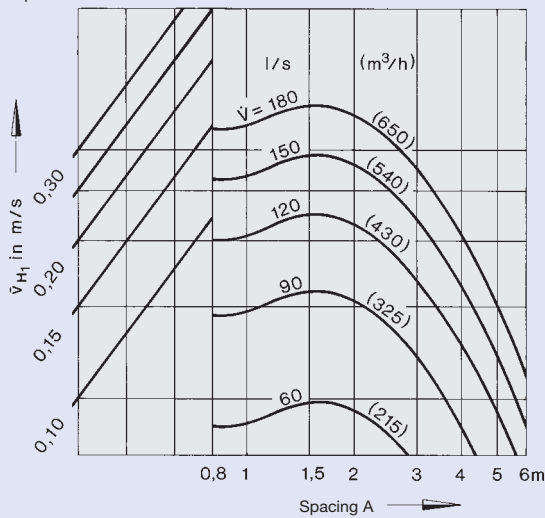

37 Temperature Quotient

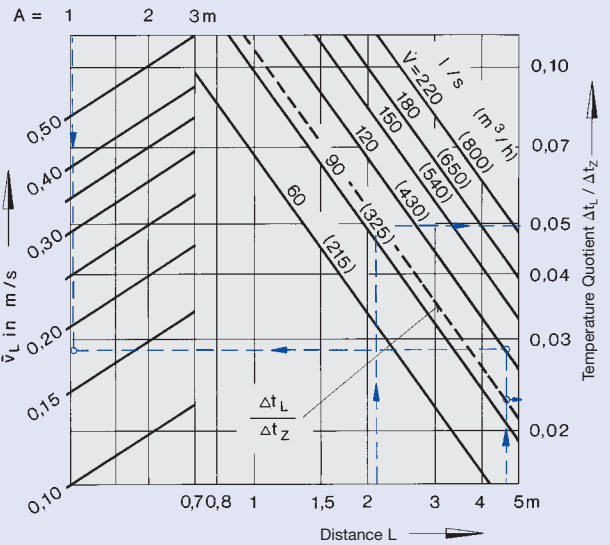

36 Diffuser arrangement: more than one row if $B = 3.00 \text{ m}$
 $H_1 = 0.9 \text{ 1.2 1.6 2m}$

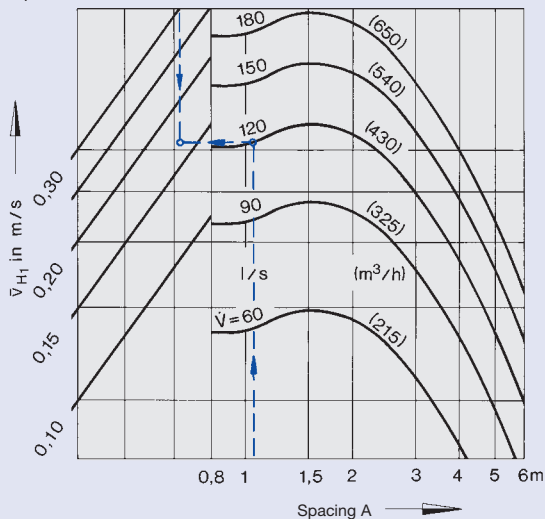

38 Square diffuser

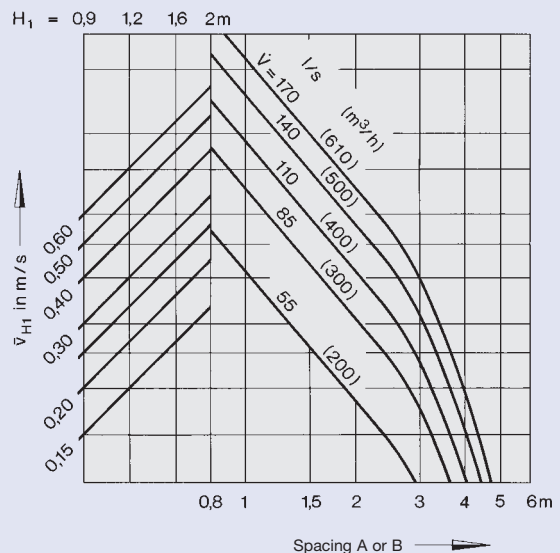

Aerodynamic Data

Size 625 x 54

Correction!

For an installation below a continuous ceiling, the values \bar{v}_{H1} , \bar{v}_L , and $\Delta t_L / \Delta t_z$ must be multiplied by a factor of 0.71!

For adjustment of blade rings for external swirl, the diagram values must be multiplied by 1.25!

39 Diffuser arrangement:
single row or more than one row if $B > 4.00$ m

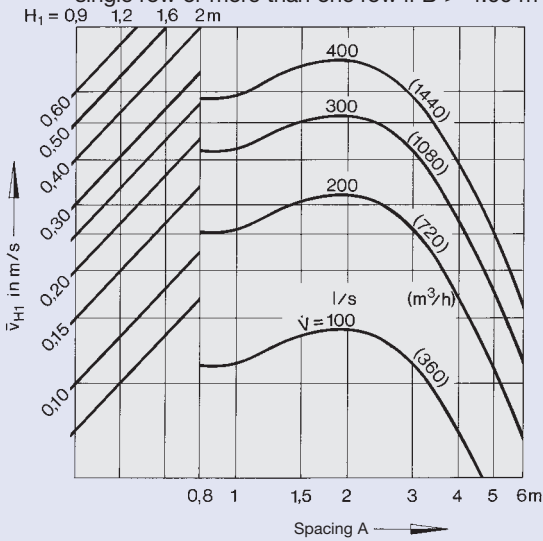

41 Temperature Quotient

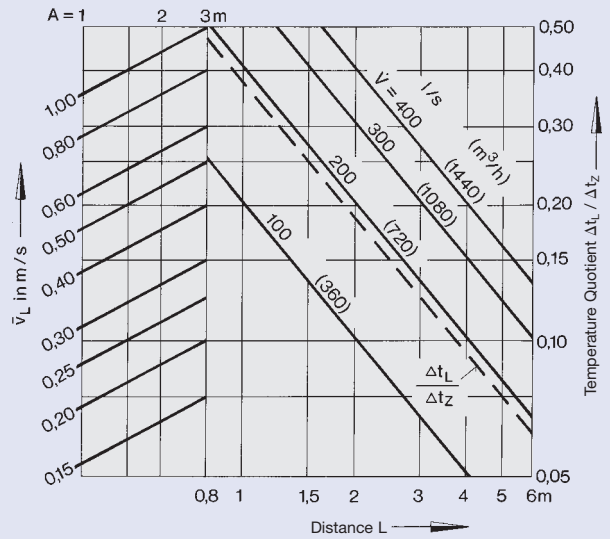

40 Diffuser arrangement:
more than one row if $B = 3.00$ m

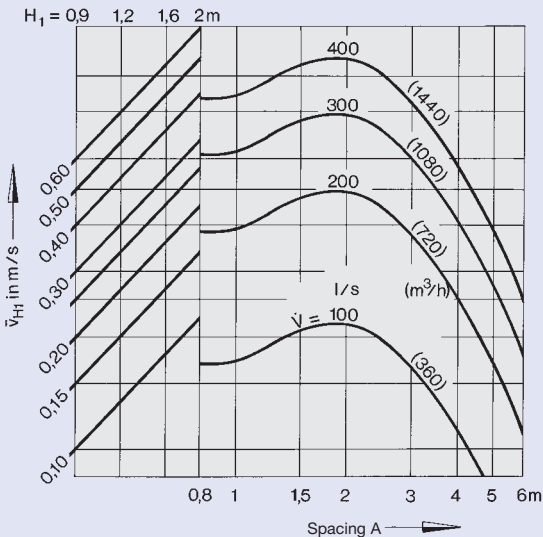

42 Square diffuser

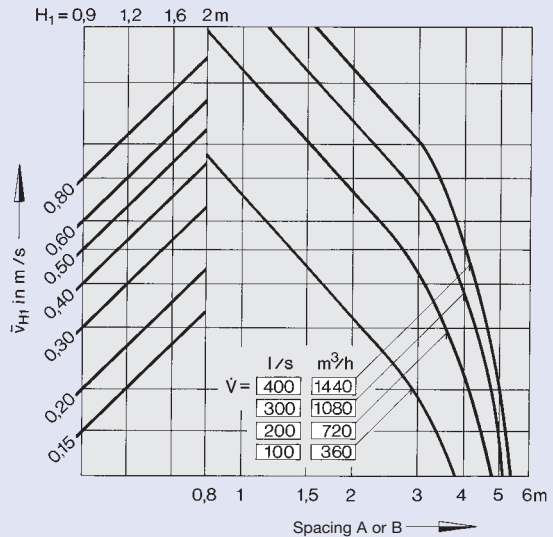

Correction!

For an installation below a continuous ceiling, the values \bar{v}_{H1} , \bar{v}_L , and $\Delta t_L / \Delta t_z$ must be multiplied by a factor of 0.71!

For adjustment of blade rings for external swirl, the diagram values must be multiplied by 1.25!

43 Diffuser arrangement:
single row or more than one row if $B > 4.00$ m

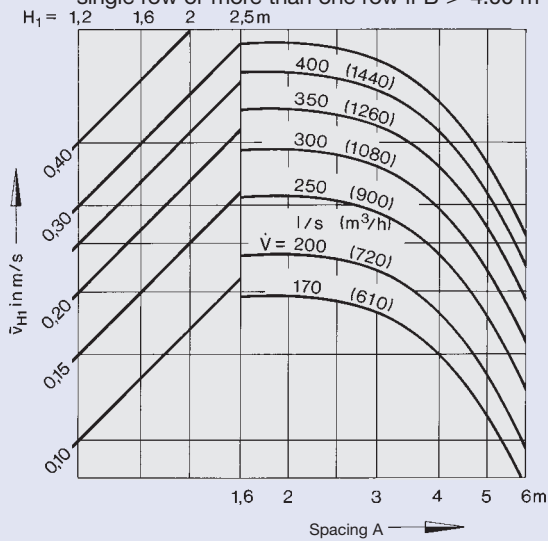

44 Diffuser arrangement:
more than one row if $B = 3.00$ m

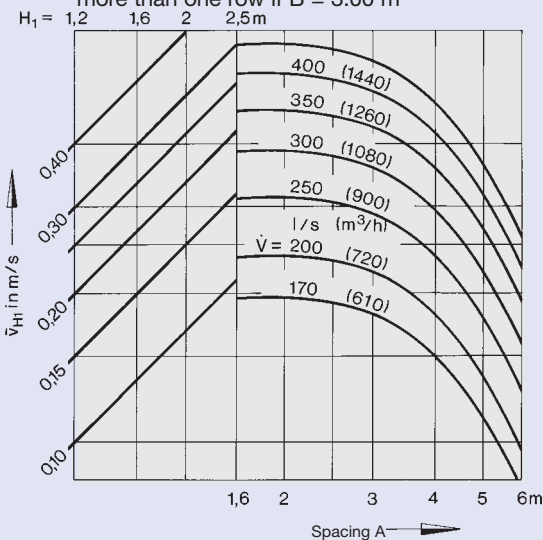

45 Temperature Quotient

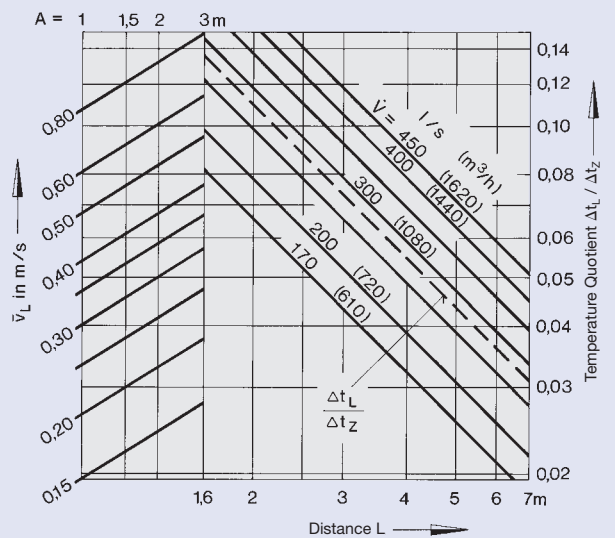

46 Square diffuser

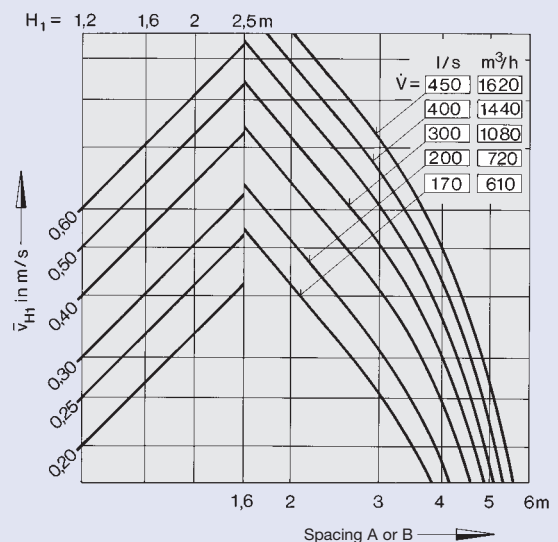

Order Details

Order Code

These codes do not need to be completed for standard products

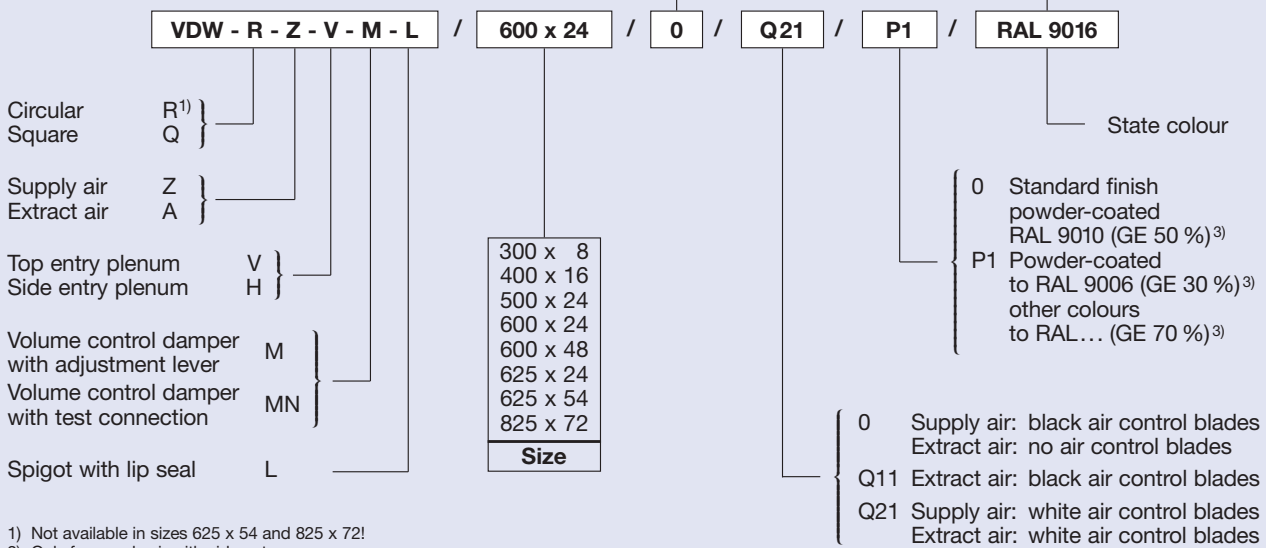

Specification Test

Adjustable swirl diffusers in square or circular face plates with swirling horizontal discharge of supply air with high induction. For air change rates up to approximately 30 per hour. Consisting of a pressed front face with radially angled air discharge sections incorporating adjustable directional air control blades. Supplied with plenum box incorporating special internal control elements, complete with circular top or side entry spigots (with optional volume control damper, lip seal or test connection for reference pressure measurement, sheathed cable and test nipple). Plenum box has holes in the top return edge for suspension or, when supplied, can be fixed by hanging brackets. The face plate can be fitted and removed by means of the centre fixing screw.

Material:

The face plate is in galvanised sheet steel. The surfaces are pre-treated and powder coated white (RAL 9010).

The control blades are made from Polystyrol (PS 476 L), with black (similar to RAL 9005) as standard or white (similar to RAL 9010) on request.

The plenum box is made from galvanised sheet steel, the rubber lip seal.

Order example

Make: TROX

Type: VDW - R - Z - V - M / 600 x 24 / Q21 / P1 / RAL 9016