

# Ceiling air diffuser WAVEDRALL

- Type WD
- circular and circular/square

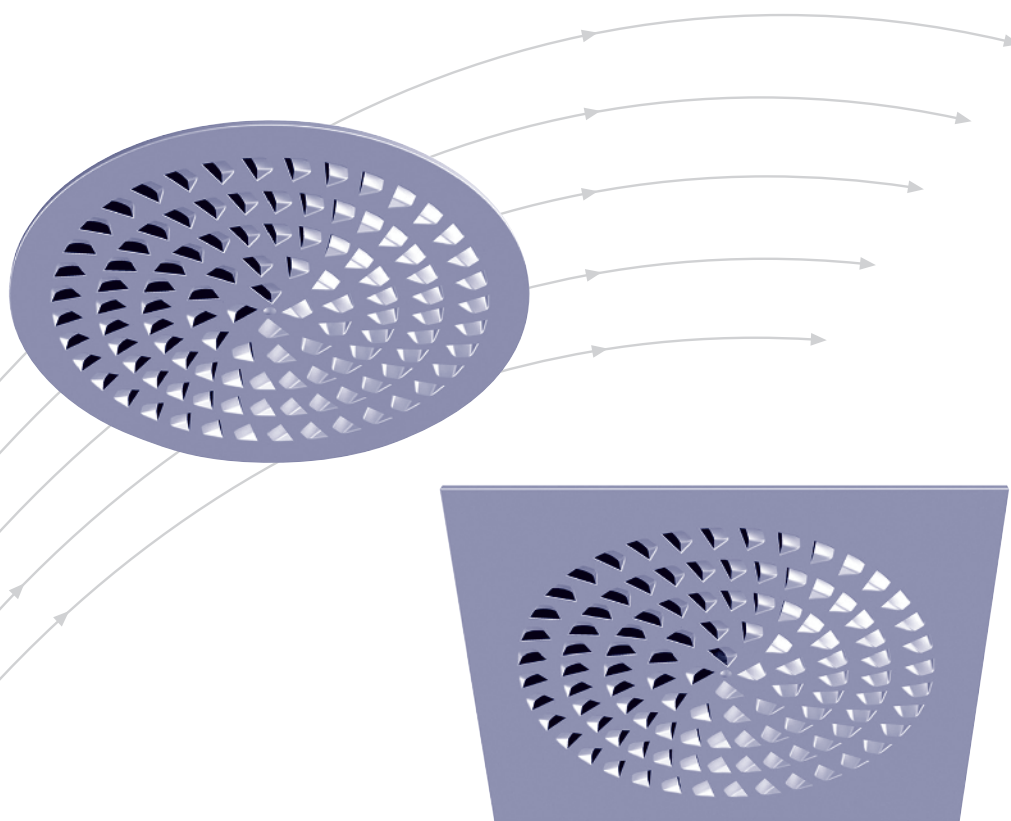

Int. mod. prot. reg.

**TROX**® **TECHNIK** 

TROX HESCO Schweiz AG  
Walderstrasse 125  
Postfach 455  
CH - 8630 Rüti ZH

Tel. +41 (0)55 250 71 11  
Fax +41 (0)55 250 73 10  
[www.troxhesco.ch](http://www.troxhesco.ch)  
[info@troxhesco.ch](mailto:info@troxhesco.ch)

# Contents · Realisation · Dimensions · Application

## Contents

Application · Realisation · Dimensions	2
Realisation · Dimensions	3
Installation	4 and 5
Quick selection	6
Definitions	7
Technical Data	8-13
Order details	14

## Application

The ceiling air diffuser WAVEDRALL is not only highly inductive, but also interesting from the energy standpoint. It can be installed in almost any room with a height of 2.4 to 4.4 m, for which a technical impeccable solution and perfect, aesthetic integration are considered important.

The air diffusers can be fitted harmoniously in mineral fibre and/or metal plate ceilings.

The WAVEDRALL can also be used for visual realisation, i. e. freely suspended.

The following executions are available:

circular  Type WDR

circular/square  Type WDRQ

## Realisation

### Type WDR

The ceiling air diffuser WAVEDRALL is made of steel plate, powder coated, with waveshaped, air-guiding openings arranged in a circle.

Colour RAL 9010 matt, brilliance 25%.

The **square** standard plenum box is made of galvanised steel plate and designed also for use with WAVEDRALL type WDR (needs a panel of a false ceiling with a recess of ØAs, according to table of page 4).

The **square** standard plenum box with a **circular** adapter is necessary for the **visual realisation**, i.e. freely suspended.

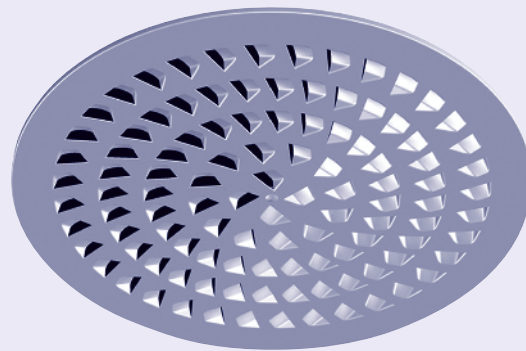

## Dimensions

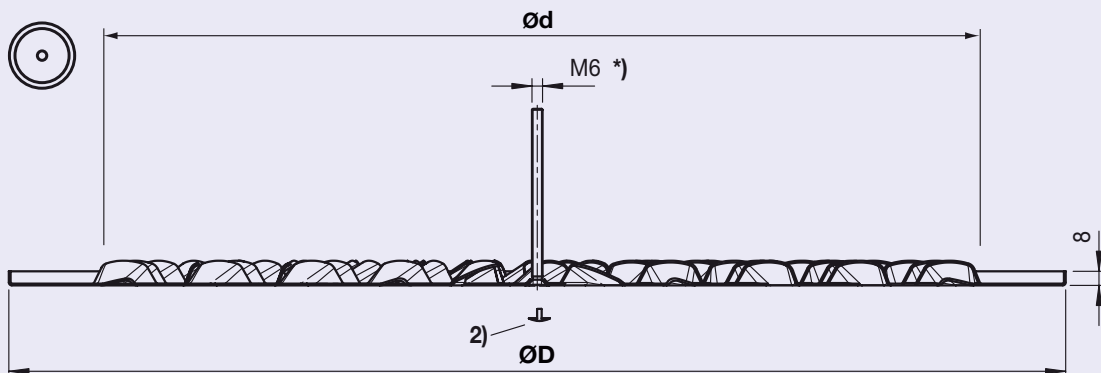

2) Plastic plug

\*) Central screw M6 x 100 mm and plastic plug are delivered as loose part

Type	ND	ØD [mm]	ød [mm]	Number of air-guiding openings
 <b>WDR</b>	600×500	600	505	108
	480×400	480	401	72
	380×300	380	297	40

## Realisation

### Type WDRQ

The WAVEDRALL ceiling air diffuser is made of steel plate, powder coated, with waveshaped, air-guiding openings arranged in a circle.

Colour RAL 9010, matt, 25% brilliance.

Attachment by means of central screw.

The ceiling air diffusers are designed for supply air in ceilings with grid dimensions □ 600 or □ 625 mm.

### Remark

The WAVEDRALL circular/square type WDRQ replaces a ceiling plate.

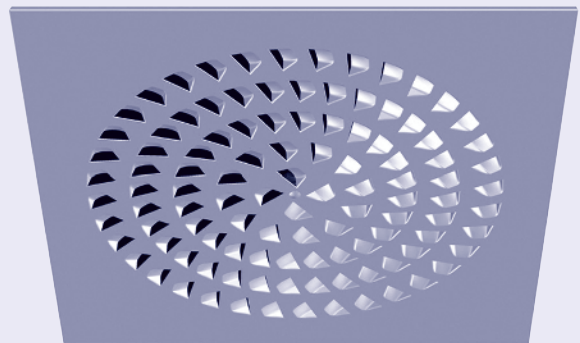

## Dimensions

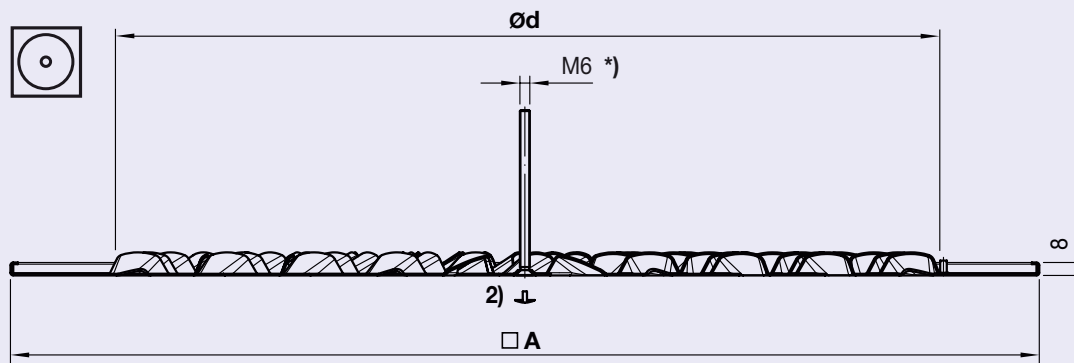

2) Plastic plug

\*) Central screw M6 x 100 mm and plastig plug are delivered as loose part

Type	ND	□ A [mm]	Ød [mm]	Grid dimension [mm]	Number of air-guiding openings
 <b>WDRQ</b>	598×500	598	505	600×600	108
	623×500	623	505	625×625	
	598×400	598	401	600×600	72
	623×400	623	401	625×625	
	598×300	598	297	600×600	40
	623×300	623	297	625×625	

# Installation

## Type WDR

Fitted in ceiling plates, already existing with **square** plenum box.

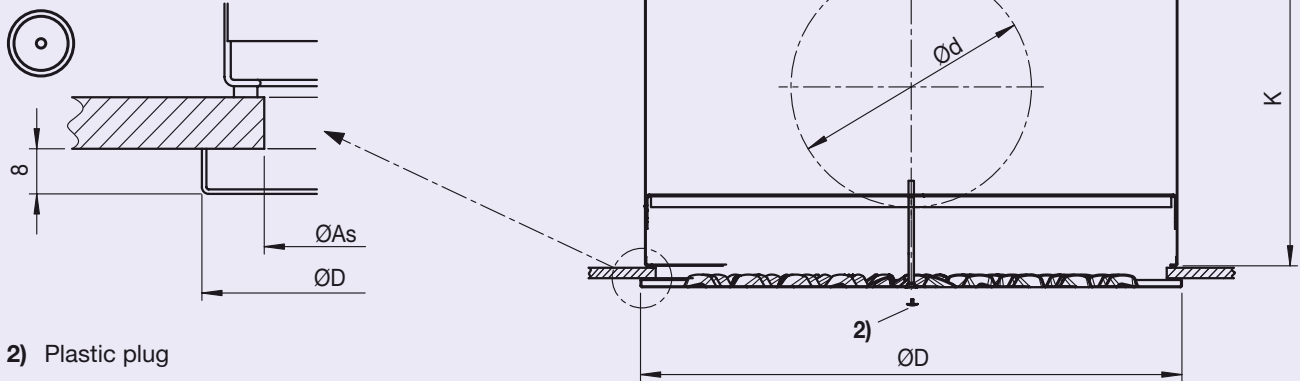

2) Plastic plug

Type	ND	Recess ØAs [mm]	Plenum box Details see prospect L-04-1-31e (TROX HESCO) or 2/16.4/... (TROX)			
			K	□ M	Ød	Type
WDR	600×500	540	345	567	1×248	AKH04 ZL M0 (TROX HESCO) [AK004 ZL M0 (TROX)]
	480×400	440	295	476	1×198	AKH03 ZL M0 (TROX HESCO) [AK003 ZL M0 (TROX)]
	380×300	340	295	372	1×198	AKH02 ZL M0 (TROX HESCO) [AK002 ZL M0 (TROX)]

## Type WDR

Visual realisation, i. e. freely suspended with square plenum box, incl. **circular** adapter.

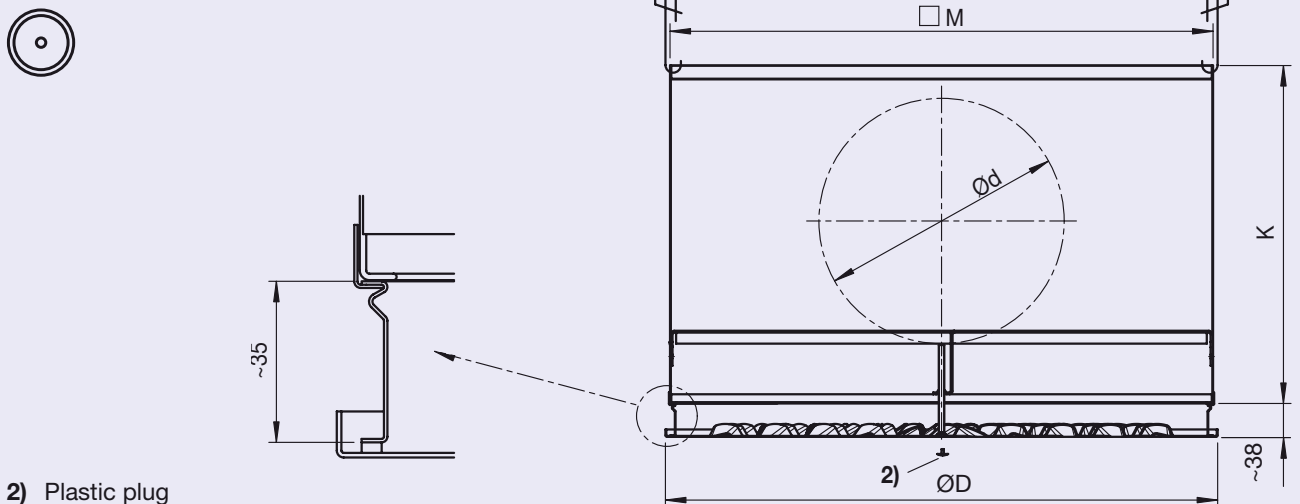

2) Plastic plug

Type	ND	Plenum box Details see prospect L-04-1-31e (TROX HESCO) or 2/16.4/... (TROX)			
		K	□ M	Ød	Typ
WDR	600×500	345	590	1×248	AK017 ZL M0 (TROX)
	480×400	295	476	1×198	AK015 ZL M0 (TROX)
	380×300	295	372	1×198	AK014 ZL M0 (TROX)

## Type WDRQ

With TROX HESCO plenum box for grid dimension  $\square$  600 or  $\square$  625 mm **pressed** onto ceiling profile **from below** with **square** plenum box.

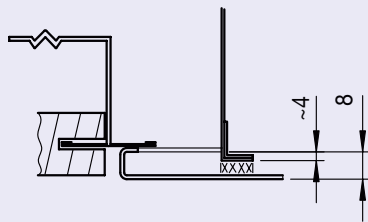

- 1) Grid dimension
- 2) Plastic plug

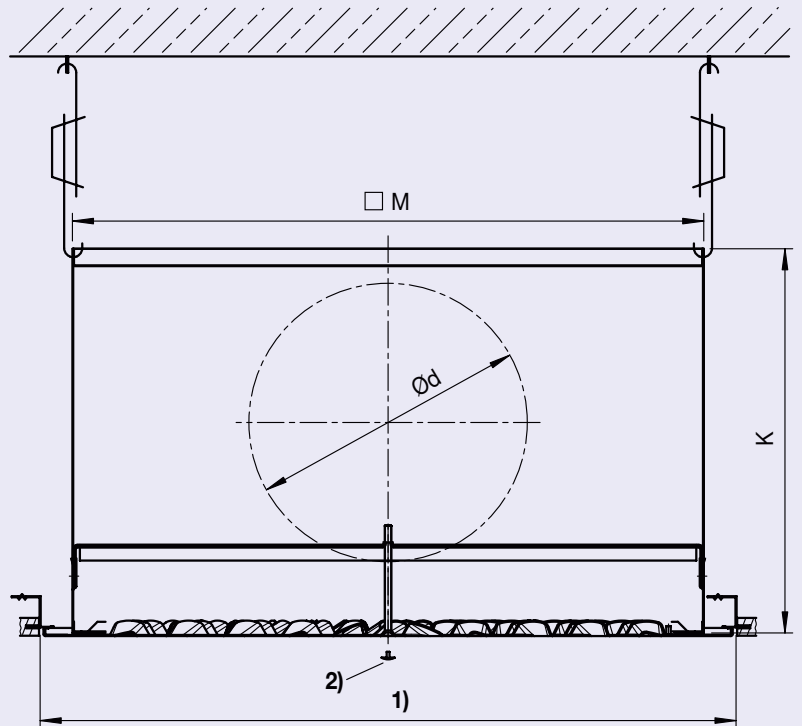

## Type WDRQ

With TROX HESCO plenum box for grid dimension  $\square$  600 or  $\square$  625 mm **inserted** in ceiling profile **from above** with **square** plenum box.

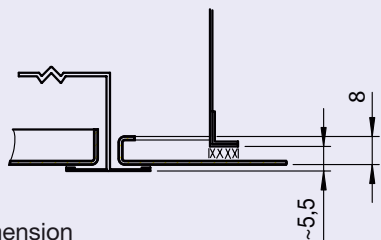

- 1) Grid dimension
- 2) Plastic plug

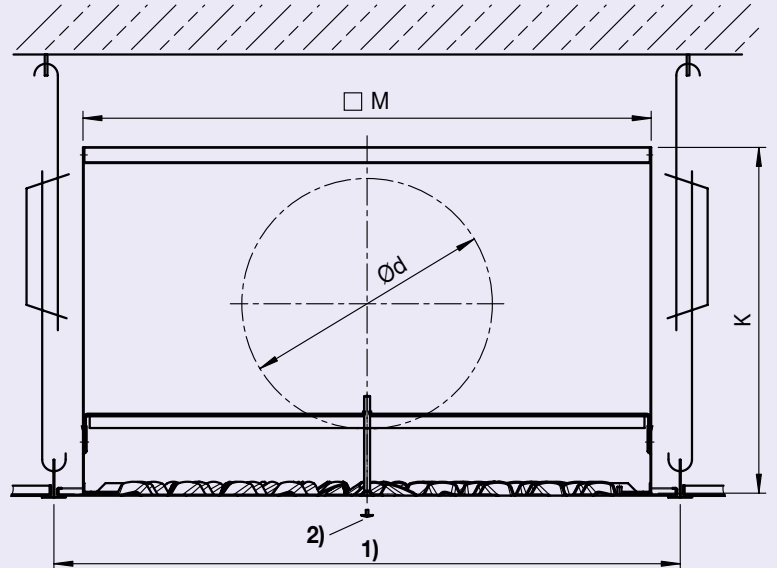

Type	ND	Grid dimension [mm]	Plenum box Details see prospect L-04-1-31e (TROX HESCO) or 2/16.4/... (TROX)			
			K	$\square$ M	Ød	Type
 <b>WDRQ</b>	598×500	600×600	345	567	1×248	<b>AKH04 ZL M0 (TROX HESCO)</b> [AK004 ZL M0 (TROX)]
	623×500	625×625				
	598×400	600×600	295	476	1×198	<b>AKH03 ZL M0 (TROX HESCO)</b> [AK003 ZL M0 (TROX)]
	623×400	625×625				
	598×300	600×600	295	372	1×198	<b>AKH02 ZL M0 (TROX HESCO)</b> [AK002 ZL M0 (TROX)]
	623×300	625×625				

# Quick selection

Type WDR / WDRQ



<b>ND</b>	<b>A<sub>eff</sub></b> [m <sup>2</sup> ]	$\dot{q}_v$ [l/s]	<b>27.8</b>		<b>34.7</b>		<b>41.7</b>		<b>48.6 nominal</b>		<b>55.6</b>		<b>62.5</b>	
		$\dot{V}$ [m <sup>3</sup> /h]	<b>100</b>		<b>125</b>		<b>150</b>		<b>175</b>		<b>200</b>		<b>225</b>	
<b>...x300</b>	0.0149	$\Delta p_t$ [Pa]	6		9		13		17		23		28	
		$L_{wA}$ [dB(A)]	<20		23		28		31		35		38	
		$L_{0.5/L_{0.3}}$ [m]	-	-	-	-	-	-	-	1.7	-	1.7	1.7	1.8
		$\bar{v}_{H1}$ [m/s]	-		-		-		-		0.09	0.10		0.11
<b>Distance</b>	A	[m]								3.3	3.4		3.3	3.6

<b>ND</b>	<b>A<sub>eff</sub></b> [m <sup>2</sup> ]	$\dot{q}_v$ [l/s]	<b>27.8</b>		<b>41.7</b>		<b>55.6</b>		<b>69.4</b>		<b>83.3 nominal</b>		<b>97.2</b>		<b>111.1</b>	
		$\dot{V}$ [m <sup>3</sup> /h]	<b>100</b>		<b>150</b>		<b>200</b>		<b>250</b>		<b>300</b>		<b>350</b>		<b>400</b>	
<b>...x400</b>	0.0268	$\Delta p_t$ [Pa]	2		4		8		12		18		25		33	
		$L_{wA}$ [dB(A)]	<20		<20		24		30		34		38		42	
		$L_{0.5/L_{0.3}}$ [m]	-	-	-	-	-	1.7	-	1.7	1.7	1.9	1.7	2.0	1.8	2.0
		$\bar{v}_{H1}$ [m/s]	-		-		-		0.09	0.10		0.12	0.11	0.14	0.12	0.16
<b>Distance</b>	A	[m]						3.3	3.4		3.3	3.7	3.4	4.1	3.6	4.4

<b>ND</b>	<b>A<sub>eff</sub></b> [m <sup>2</sup> ]	$\dot{q}_v$ [l/s]	<b>41.7</b>		<b>55.6</b>		<b>69.4</b>		<b>83.3</b>		<b>97.2</b>		<b>111.1 nominal</b>		<b>125.0</b>		<b>138.9</b>	
		$\dot{V}$ [m <sup>3</sup> /h]	<b>150</b>		<b>200</b>		<b>250</b>		<b>300</b>		<b>350</b>		<b>400</b>		<b>450</b>		<b>500</b>	
<b>...x500</b>	0.0402	$\Delta p_t$ [Pa]	2		4		6		8		11		15		18		23	
		$L_{wA}$ [dB(A)]	<20		<20		<20		24		28		32		35		37	
		$L_{0.5/L_{0.3}}$ [m]	-	-	-	-	-	1.7	1.7	1.8	1.7	2.0	1.8	2.1	1.8	2.3	2.0	2.4
		$\bar{v}_{H1}$ [m/s]	-		-		-		0.10	0.12	0.11	0.14	0.12	0.15	0.13	0.17	0.14	0.18
<b>Distance</b>	A	[m]						3.4	3.3	3.6	3.4	3.9	3.5	4.2	3.7	4.5	3.9	4.8

**Basis** zu  $\bar{v}_{H1}$ :

- Room height H = 2.9 m
- Height of the occupied zone = 1.7 m
- H<sub>1</sub> = 1.2 m
- Distance A see table
- Distance B = 4.0 m
- Difference of temperature = -8.0 K

# Definitions

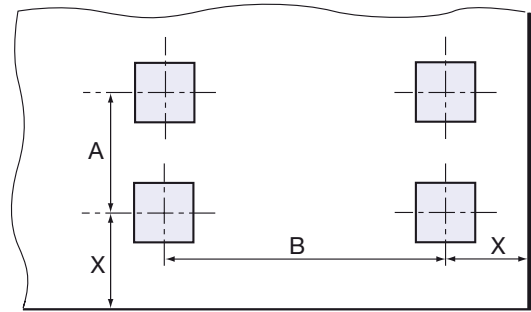
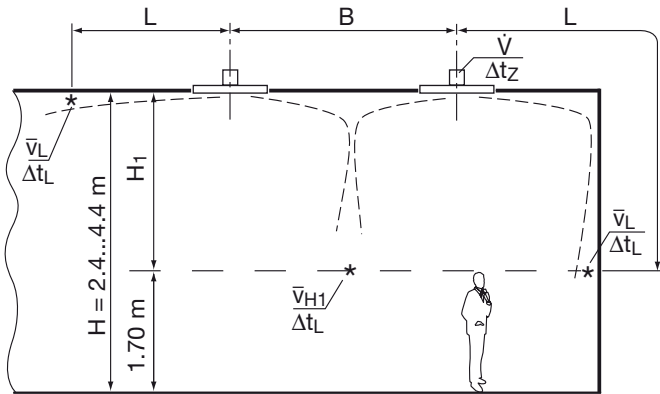

L	m	Distance blowing against the wall
$L_{0.5}/L_{0.3}$	m	Distance of the jet in relation to the end velocities 0.5 m/s resp. 0.3 m/s
$\dot{q}_v$	l/s	Volume flow rate per diffuser
$\dot{V}$	m <sup>3</sup> /h	Volume flow rate per diffuser
$\dot{V}_{\text{nominal}}$	m <sup>3</sup> /h	Nominal volume (flow rate with VAV: $\dot{V}_{\text{max}} = 1.19 \times \dot{V}_{\text{nominal}}$ )
$v_{\text{eff}}$	m/s	eff. discharge velocity
A, B	m	Distance between the axes of two diffusers
X	m	Distance between diffuser centre and wall
H	m	Room height
$H_1$	m	Distance between ceiling and occupied zone
$\bar{v}_{H1}$	m/s	Mean flow velocity of room air between two diffusers in ceiling distance $H_1$
$\bar{v}_L$	m/s	Mean flow velocity of room air between wall in ceiling distance $H_1$
$t_R$	°C	Room air temperature
$t_L$	°C	Jet air temperature
$\Delta t_z$	K	Difference between room air and supply air temperature
$\Delta t_L$	K	Difference between room air and jet air temperature at distance $L = A/2 + H_1$ $L = X + H_1$
$A_{\text{eff}}$	m <sup>2</sup>	Effective air outlet surface area
$\Delta p_t$	Pa	Total pressure drop (supply air)
$L_{wA}$	dB(A)	A-weighted sound power level
$L_{wNC}$		NC rating of sound power level $L_{wNC} = L_{wA} - 6 \text{ dB}$
$L_{wNR}$		$L_{wNR} = L_{wNC} + 2 \text{ dB}$
$L_{pA}, L_{pNC}$		A-weighting or NC curve respectively of room sound power level $L_{pA} \sim L_{wA} - 8 \text{ dB}$ $L_{pNC} \sim L_{wNC} - 8 \text{ dB}$
$L_{w\text{okt}}$	dB	Sound power level in the octave-centre frequencies
$\Delta L$	dB	Insertion attenuation in the octave-centre frequencies
$\Delta L_A$	dB	Octave-centre frequencies, correction value
f	Hz	Octave-centre frequencies

# Technical Data

Type WDR ...x300

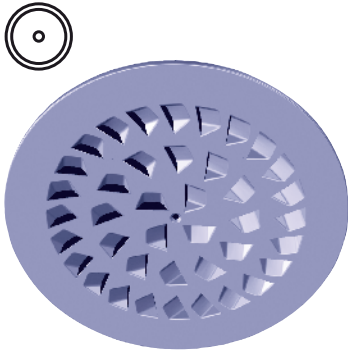

Correction table, octave-centre frequencies

f	125	250	500	1k	2k	4k	8k	[Hz]
$\Delta L_A$	6	5	-2	-10	-16	-20	-21	[dB]

Insertion attenuation (incl. end reflection)

Interior of box not insulated

f	125	250	500	1k	2k	4k	8k	[Hz]
$\Delta L$	11	6	4	5	8	10	9	[dB]

Room air velocity  $\bar{v}_{H1}$

$\Delta t_z = +8 \text{ K}$  A = B

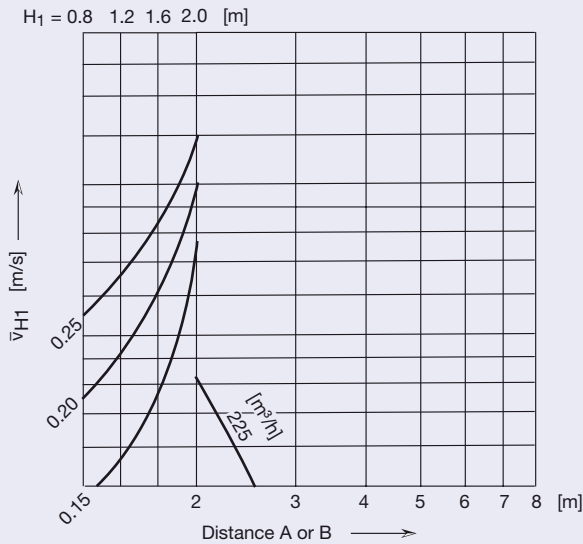

Room air velocity by the wall  $\bar{v}_L$

$\Delta t_z = -8 \text{ K}$

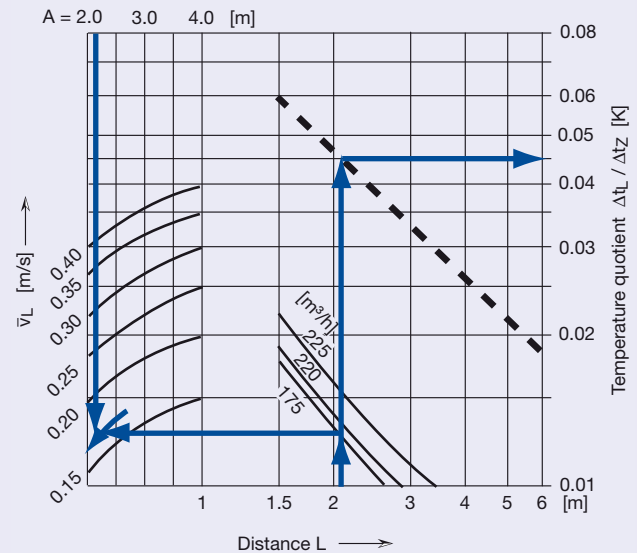

Room air velocity  $\bar{v}_{H1}$

$\Delta t_z = -8 \text{ K}$  A = B

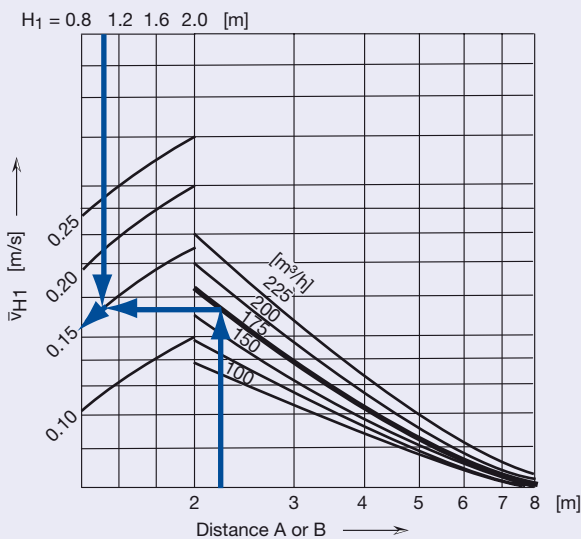

Room air velocity  $\bar{v}_{H1}$

$\Delta t_z = -12 \text{ K}$  A = B

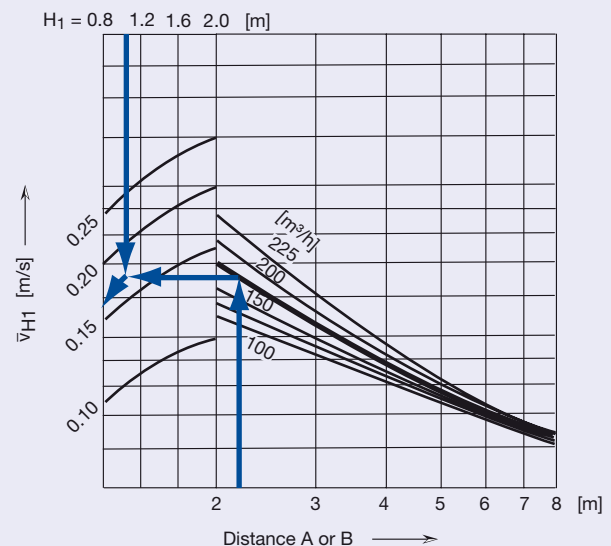

## Type WDR ...x300

### Sound power level and pressure drop

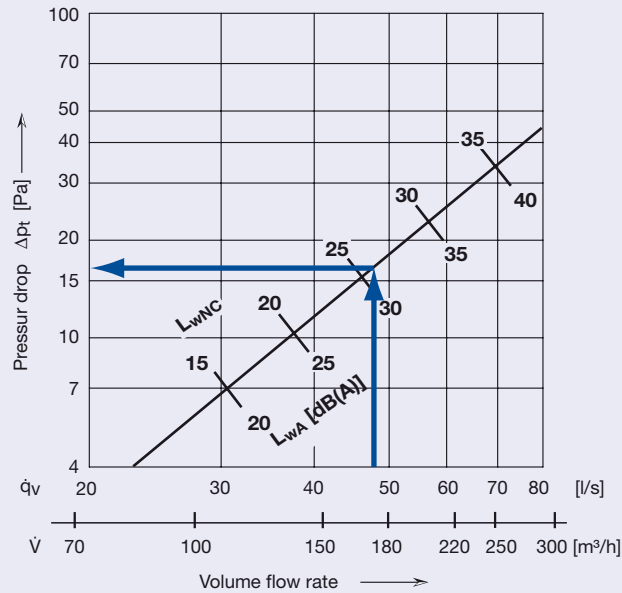

### Connection diameter

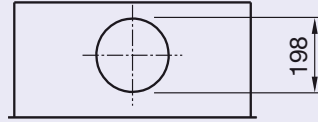

The specifications are valid for standard plenum box of TROX HESCO

### Eff. velocity of supply air

$\dot{V}$ [m³/h]	$\dot{q}_v$ [l/s]	$v_{eff}$ [m/s]	$A_{eff} = 0.0149 \text{ m}^2$
100	27.8	1.9	
125	34.7	2.3	
150	41.7	2.8	
<b>175</b>	<b>48.6</b>	<b>3.3</b>	
200	55.6	3.7	
225	62.5	4.2	
250	69.4	4.7	

### Example

#### Given

WAVEDRALL ...300	Spigot $\varnothing 198 \text{ mm}$	
Volume flow rate	49 l/s	$\dot{q}_v$
	175 m³/h	$\dot{V}$
Room height	2.7 m	H
Occupied zone height	1.7 m	
Distance to the ceiling	1.0 m	$H_1$
Distance between diffusers	2.2 m	A = B
Difference of temperature	-12 K / -8 K / +8 K	$\Delta t$

#### Solution

Sound power level	31 dB(A)	$L_{WA}$
Limite curve	26	$L_{wNC}$
Pressure drop	17 Pa	$\Delta p_t$

### Octave spectrum

f	125	250	500	1000	2000	4000	8000	[Hz]
$L_{WA}$	31	31	31	31	31	31	31	[dB(A)]
$\Delta L_A$	6	5	-2	-10	-16	-20	-21	[dB]
$L_{wOkt}$	37	36	29	21	15	11	10	[dB]

### Insertion attenuation see page 8

Room air velocity 1.7 m over ground		
at -12 K	= 0.17 m/s	$\bar{v}_{H1}$
at -8 K	= 0.15 m/s	$\bar{v}_{H1}$
at +8 K	= < 0.10 m/s	$\bar{v}_{H1}$

Velocity by the wall 1.7 m over ground		
Throw of the jet = $A/2 + H_1$	= 2.1 m	L
bei -8 K	= 0.17 m/s	$\bar{v}_L$

Difference of temperature	0.045	$\Delta t_L / \Delta t_z$
$(t_R - t_L)$ at $\Delta t_L -8 \text{ K} = 0.045 \times 8$	= ~0.4 K	$\Delta t_L$

# Technical Data

Type WDR ...x400

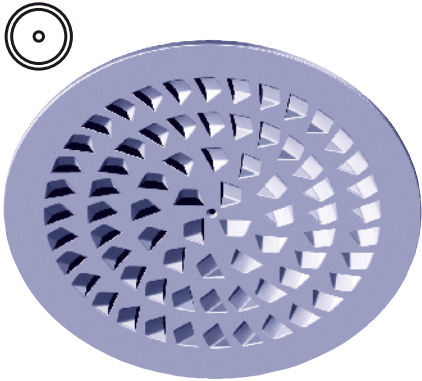

Correction table, octave-centre frequencies

f	125	250	500	1k	2k	4k	8k	[Hz]
$\Delta L_A$	4	6	-2	-10	-14	-17	-18	[dB]

Insertion attenuation (incl. end reflection)

Interior of box not insulated

f	125	250	500	1k	2k	4k	8k	[Hz]
$\Delta L$	11	6	4	5	8	10	9	[dB]

Room air velocity  $\bar{v}_{H1}$

$\Delta t_z = +8 \text{ K}$  A = B

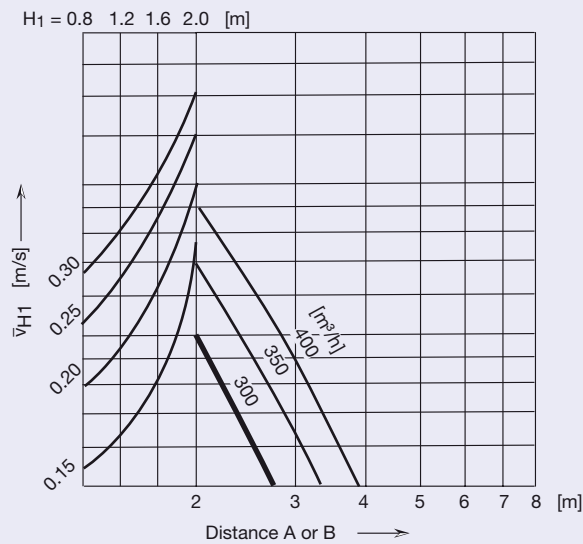

Room air velocity by the wall  $\bar{v}_L$

$\Delta t_z = -8 \text{ K}$

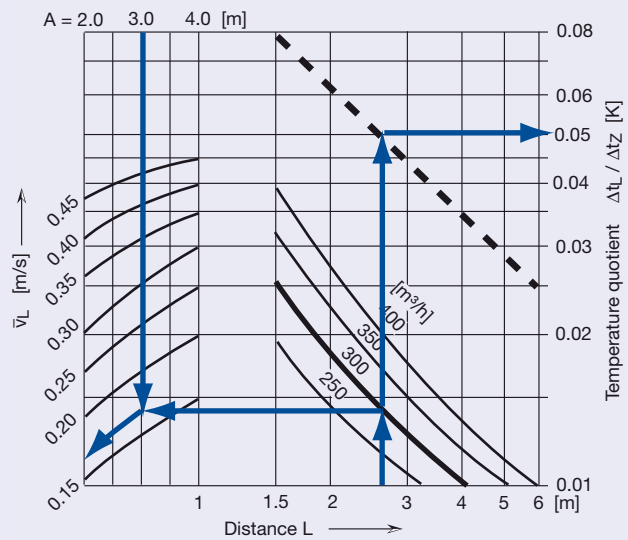

Room air velocity  $\bar{v}_{H1}$

$\Delta t_z = -8 \text{ K}$  A = B

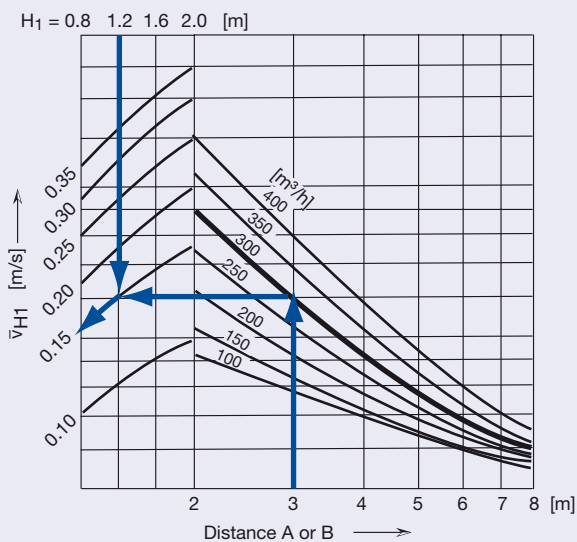

Room air velocity  $\bar{v}_{H1}$

$\Delta t_z = -12 \text{ K}$  A = B

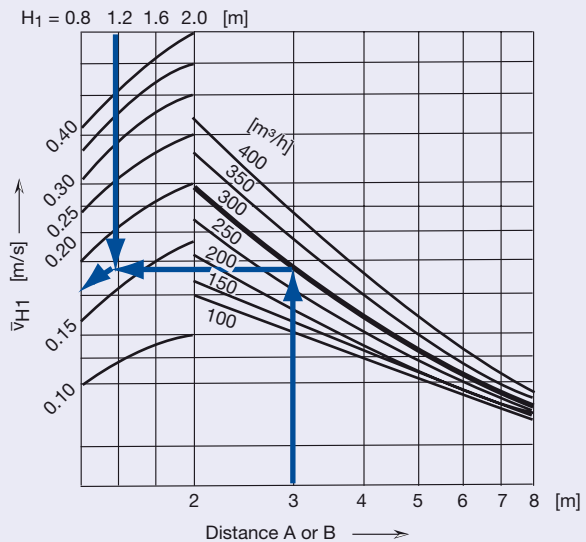

## Type WDR ...x400

### Sound power level and pressure drop

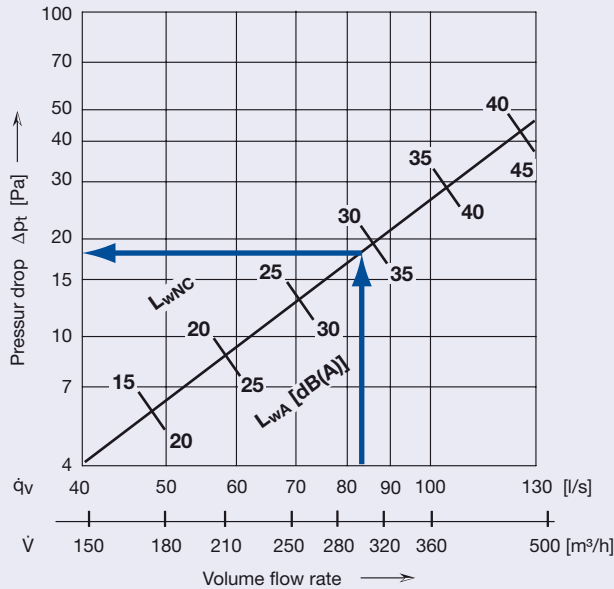

### Connection diameter

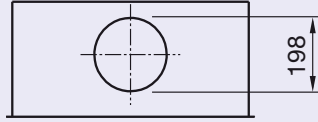

The specifications are valid for standard plenum box of TROX HESCO

### Eff. velocity of supply air

$\dot{V}$ [m³/h]	$q_v$ [l/s]	$v_{eff}$ [m/s]	$A_{eff} = 0.0268 \text{ m}^2$
100	27.8	1.0	
150	41.7	1.6	
200	55.6	2.1	
250	69.4	2.6	
<b>300</b>	<b>83.3</b>	<b>3.1</b>	
350	97.2	3.6	
400	111.1	4.1	
450	125.0	4.7	

### Example

#### Given

WAVEDRALL ...400	Spigot $\varnothing 198 \text{ mm}$	
Volume flow rate	83 l/s	$\dot{q}_v$
	300 m³/h	$\dot{V}$
Room height	2.9 m	H
Occupied zone height	1.7 m	
Distance to the ceiling	1.2 m	$H_1$
Distance between diffusers	3.0 m	A = B
Difference of temperature	-12 K / -8 K / +8 K	$\Delta t$

#### Solution

Sound power level	34 dB(A)	$L_{wA}$
Limite curve	29	$L_{wNC}$
Pressure drop	18 Pa	$\Delta p_t$

### Octave spectrum

f	125	250	500	1000	2000	4000	8000	[Hz]
<b>L<sub>wA</sub></b>	34	34	34	34	34	34	34	<b>[dB(A)]</b>
$\Delta L_A$	4	6	-2	-10	-14	-17	-18	<b>[dB]</b>
<b>L<sub>wOkt</sub></b>	38	40	32	24	20	17	16	<b>[dB]</b>

### Insertion attenuation see page 10

Room air velocity 1.7 m over ground		
at -12 K	= 0.17 m/s	$\bar{v}_{H1}$
at -8 K	= 0.15 m/s	$\bar{v}_{H1}$
at +8 K	= < 0.10 m/s	$\bar{v}_{H1}$

Velocity by the wall 1.7 m over ground		
Throw of the jet = $A/2 + H_1$	= 2.7 m	L
at -8 K	= 0.17 m/s	$\bar{v}_L$

Difference of temperature	0.05	$\Delta t_L / \Delta t_z$
$(t_R - t_L)$ at $\Delta t_L -8 \text{ K} = 0.05 \times 8$	= ~0.4 K	$\Delta t_L$

# Technical Data

Type WDR ...x500

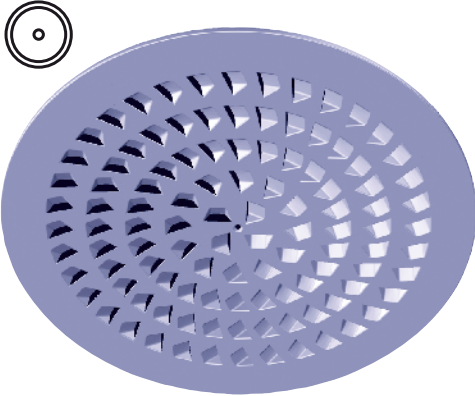

Correction table, octave-centre frequencies

f	125	250	500	1k	2k	4k	8k	[Hz]
$\Delta L_A$	5	5	-2	-11	-17	-13	-15	[dB]

Insertion attenuation (incl. end reflection)

Interior of box not insulated

f	125	250	500	1k	2k	4k	8k	[Hz]
$\Delta L$	11	6	4	5	8	10	9	[dB]

Room air velocity  $\bar{v}_{H1}$

$\Delta t_z = +8 \text{ K}$  A = B

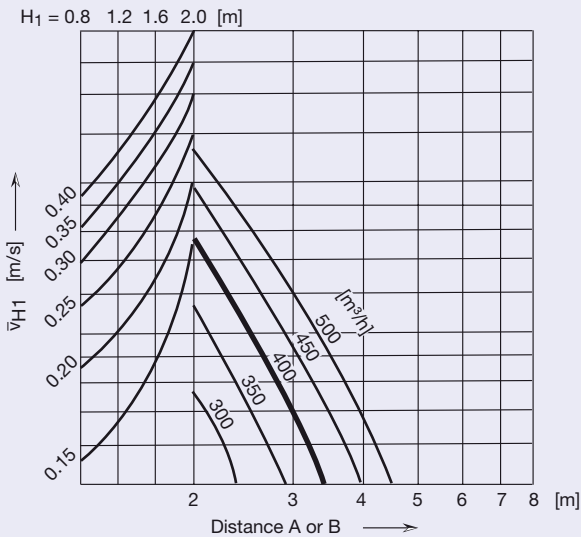

Room air velocity by the wall  $\bar{v}_L$

$\Delta t_z = -8 \text{ K}$

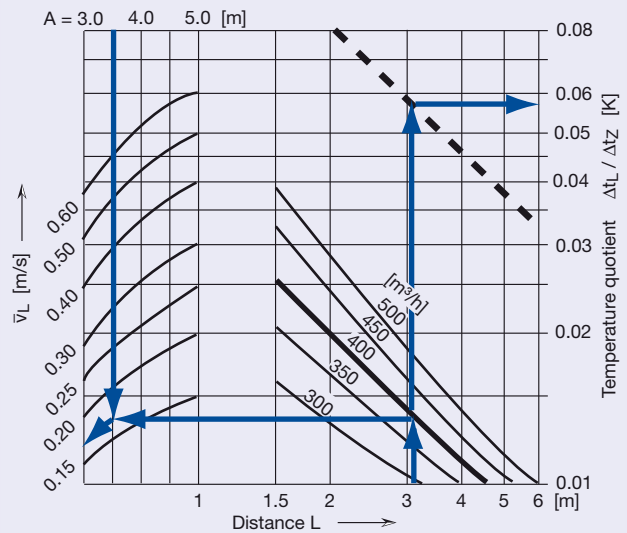

Room air velocity  $\bar{v}_{H1}$

$\Delta t_z = -8 \text{ K}$  A = B

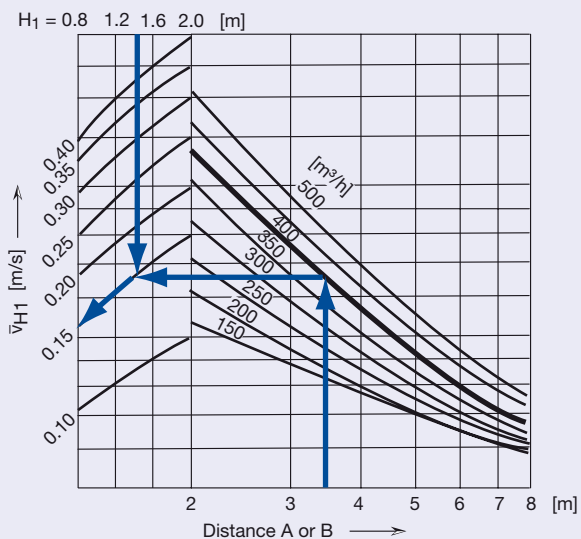

Room air velocity  $\bar{v}_{H1}$

$\Delta t_z = -12 \text{ K}$  A = B

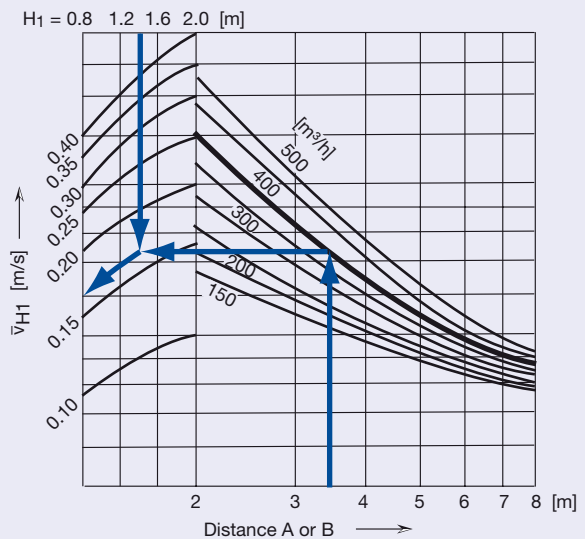

## Type WDR ...x500

### Sound power level and pressure drop

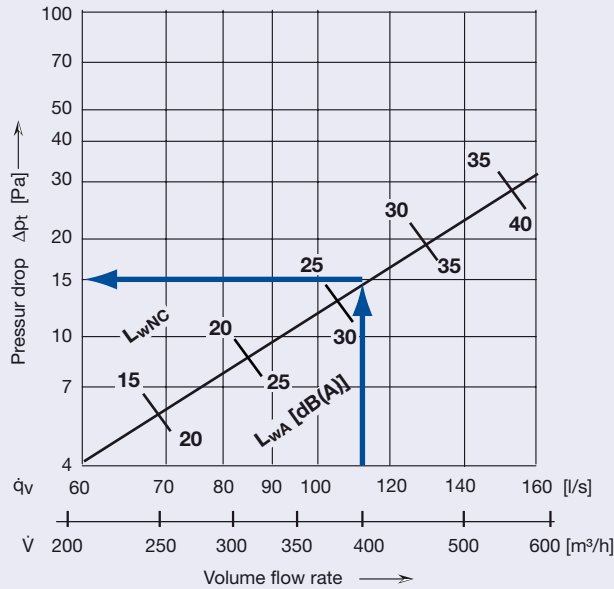

### Connection diameter

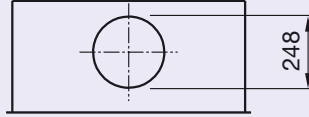

The specifications are valid for standard plenum box of TROX HESCO

### Eff. velocity of supply air

$\dot{V}$ [m³/h]	$\dot{q}_v$ [l/s]	$v_{eff}$ [m/s]	$A_{eff} = 0.0402 \text{ m}^2$
150	41.7	1.0	
200	55.6	1.4	
250	69.4	1.7	
300	83.3	2.1	
350	97.2	2.4	
<b>400</b>	<b>111.1</b>	<b>2.8</b>	
450	125.0	3.1	
500	138.9	3.5	
550	152.8	3.8	

### Example

#### Given

WAVEDRALL ...500	Spigot Ø248 mm	
Volume flow rate	111 l/s	$\dot{q}_v$
	400 m³/h	$\dot{V}$
Room height	3.1 m	H
Occupied zone height	1.7 m	
Distance to the ceiling	1.4 m	$H_1$
Distance between diffusers	3.5 m	A = B
Difference of temperature	-12 K / -8 K / +8 K	$\Delta t$

#### Solution

Sound power level	32 dB(A)	$L_{wA}$
Limite curve	27	$L_{wNC}$
Pressure drop	15 Pa	$\Delta p_t$

### Octave spectrum

f	125	250	500	1000	2000	4000	8000	[Hz]
<b>L<sub>wA</sub></b>	32	32	32	32	32	32	32	<b>[dB(A)]</b>
<b>ΔL<sub>A</sub></b>	5	5	-2	-11	-17	-13	-15	<b>[dB]</b>
<b>L<sub>wOkt</sub></b>	37	37	30	21	15	19	17	<b>[dB]</b>

### Insertion attenuation see page 12

Room air velocity 1.7 m over ground		
at -12 K	= 0.17 m/s	$\bar{v}_{H1}$
at -8 K	= 0.15 m/s	$\bar{v}_{H1}$
at +8 K	= < 0.10 m/s	$\bar{v}_{H1}$

Velocity by the wall 1.7 m over ground		
Throw of the jet = A/2 + H <sub>1</sub>	= 3.15 m	L
at -8 K	= 0.17 m/s	$\bar{v}_L$

Difference of temperature	0.06	$\Delta t_L / \Delta t_z$
(t <sub>R</sub> - t <sub>L</sub> ) at $\Delta t_L$ -8 K = 0.06 × 8	= ~0.5 K	$\Delta t_L$

# Order details

## Order code

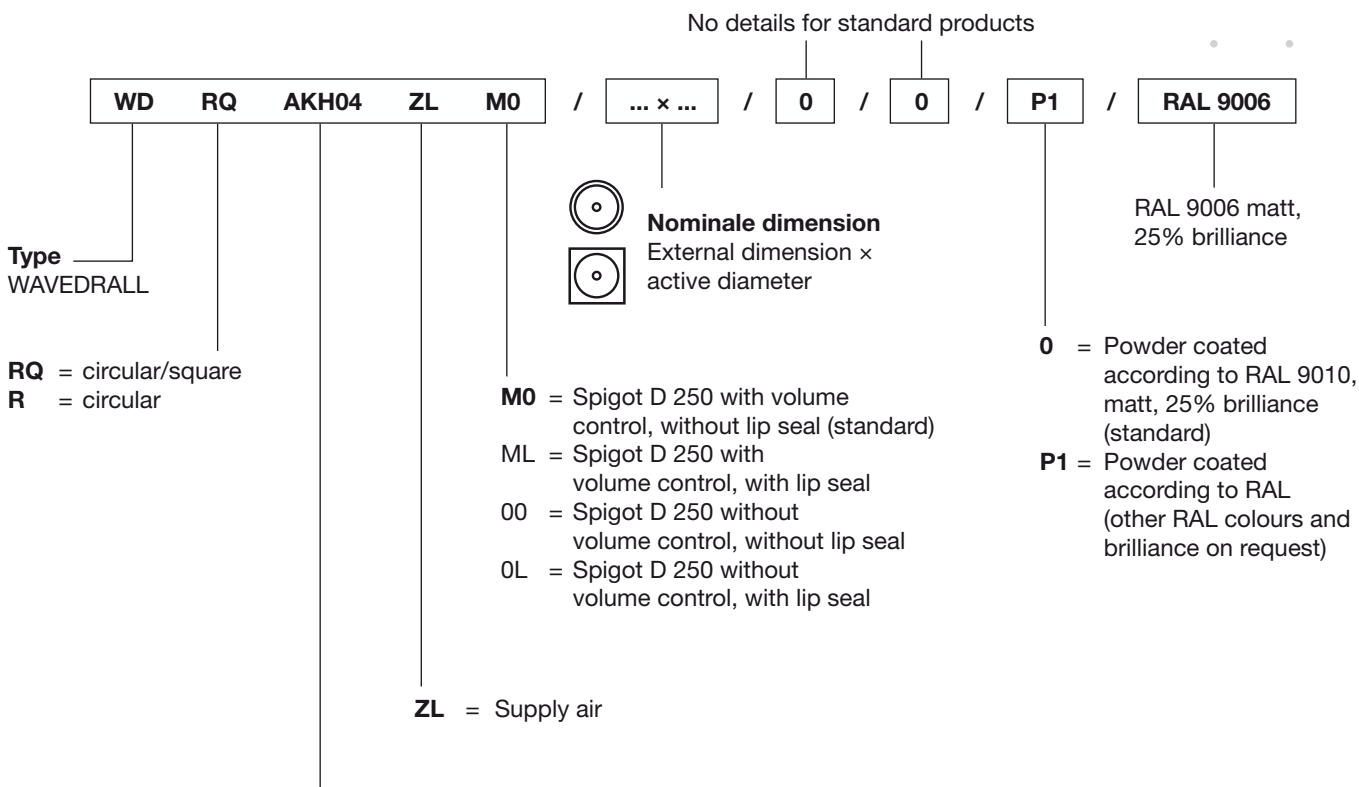

- 0** = Without plenum box
- AKH02ZL...** = TROX HESCO plenum box
- AK002ZL...** = TROX plenum box
- AKH03ZL...** = TROX HESCO plenum box
- AK003ZL...** = TROX plenum box
- AKH04ZL...** = TROX HESCO plenum box
- AK004ZL...** = TROX plenum box
- AK014ZL...** = TROX plenum box
- AK015ZL...** = TROX plenum box
- AK017ZL...** = TROX plenum box

### Order examples

- 45 off      WDRQ AKH04ZL M0 / 623x500
- 30 off      WDRQ AKH04ZL M0 / 598x500 / P1 / RAL 9006
- 20 off      WDR / 480x400
- 25 off      WDR AKH02ZL ML / 380x300 / P1 / RAL 9006

### Text for tendering purposes

The WAVEDRALL ceiling air diffuser is made of steel plate, powder coated, with waveshaped, air-guiding openings arranged in a circle.

Attachment by means of central screw (delivered separately). A standard plenum box of galvanised steel, with integrated cross bar for the M6 central screw, for quick and simple installation of the ceiling panel air diffuser. A connection with volume control for connecting a coiled tube or hose is included; the inlet box also contains an air distributor element.

### Material

- Ceiling air diffuser: Steel, colour RAL 9010, matt, 25% brilliance
- Plenum box: Galvanised steel plate

Details for the plenum box see pages 4 and 5.

The **square** standard plenum box, incl. **circular** adapter, is necessary for visual realisation, i. e. freely suspended.

### Option

- Other RAL colours
- Utilisation for exhaust air

We reserve the right to make design and shade of colour changes (11/2008)