

VARYCONTROL VAV Control Units

for variable volume systems
Type TVJ · TVT



TROX[®] TECHNIK

The art of handling air

Contents · Description

Description _____	2	Aerodynamic data _____	8
Functional description _____	3	Acoustic quick selection _____	10
Construction · Dimensions _____	4	Air-regenerated noise with TX secondary silencer _____	11
Nomenclature · Shut-off position TVJ _____	5	Air-regenerated noise without secondary silencer _____	12
TX secondary silencer _____	6	Case-radiated noise _____	13
Dimensions _____	7	Order details _____	14



TROX VARYCONTROL VAV unit Type TVJ and TVT, as well as TVJD and TVTD have been developed for the control of air flow, especially in variable volume flow systems.

- TVJ: Rectangular volume flow controller for supply or extract air
- TVJD: Rectangular volume flow controller for supply or extract air with additional acoustic cladding
- TVT: Rectangular volume flow controller for supply or extract air, very low leakage in the shut-off position
- TVTD: Rectangular volume flow controller for supply or extract air, with additional acoustic cladding, very low leakage in the shut-off position

The mechanical components and electronic control components which are factory fitted, form the controls package. Each unit is set up to the required flow rates and is subjected to an aerodynamic function test.

The units are fitted with an averaging differential pressure grid for measuring the air flow and a multileaf damper to provide the control function.

The units have a flange on both ends for connection to the ducting.

For more stringent acoustic requirements, the TVJD or TVTD units with additional acoustic cladding and/or a TX secondary silencer may be used.

The flow rate control is a closed loop system with external power supply. The pressure transmitter, controller and actuator are selected to meet control requirements and operational conditions. TROX VAV units can be supplied with control components from any reputable manufacturer to suit the project specification.

Further, current information on application, selection as well as control components available can be found in the "Technical Documentation" download area of our website.

Also available on the Internet is the "volume flow controller" online program for the design and selection of our units.

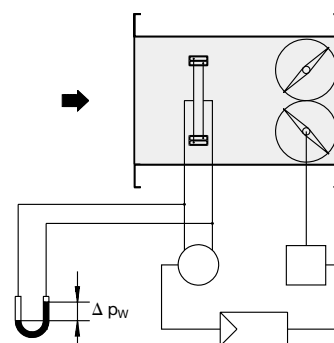

Δp_w in Pa = differential pressure at the differential pressure grid

Functional Description

Room temperature controller

In VAV systems, the room temperature control takes the form of a cascade control. The primary controlled variable is the room temperature. The output signal of the room temperature controller is not fed directly to the supply air control damper, but alters the setpoint value of the supply air volume flow rate control loop. The volume flow control also generates minimum and maximum limits for the air flow which has benefits in keeping the room temperature constant and for the functioning of the overall room air conditioning system.

Volume flow measurement

A sensor is necessary for the positive measurement of air flows, this is achieved by pressure measurement at several points distributed over the cross-section and provision of the resulting average value. The TROX differential pressure sensor is an optimum solution in terms of economics and product technology. This sensor delivers exact results for most room air conditioning applications based on normal flow entry conditions.

Volume flow control

The volume flow is controlled in a closed control loop, i.e. measurement – comparison – control.

A pressure transmitter converts the pressure difference into an electrical signal, which is interpreted as the actual value by the controller. In most applications, the setpoint value comes from a room temperature controller. The controller compares the actual value with the setpoint value and alters the command signal to the damper actuator in the event of a difference between the two values.

Supply air/extract air tracking control

In single rooms and closed-off office areas, the balance between supply and extract air should be maintained. Otherwise, annoying whistling noises occur at door gaps, and the doors can be difficult to open. For this reason, the extract air should have variable control in a VAV system. The actual value of the supply air is fed as a command signal to the extract air controller (tracking controller). In this way, the extract air automatically follows the supply air, even when this has not reached its set value.

System diagram

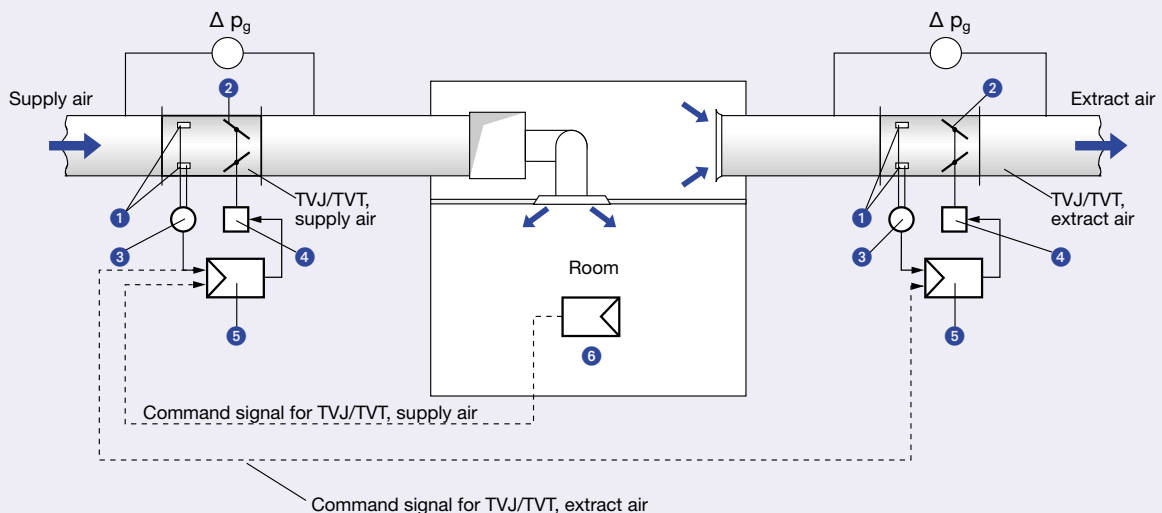

Legend

- ① Differential pressure grid
- ② Control damper
- ③ Pressure transmitter
- ④ Actuator
- ⑤ Volume flow controller
- ⑥ Room temperature controller (supplied by others)
- Wiring by others

Control diagram

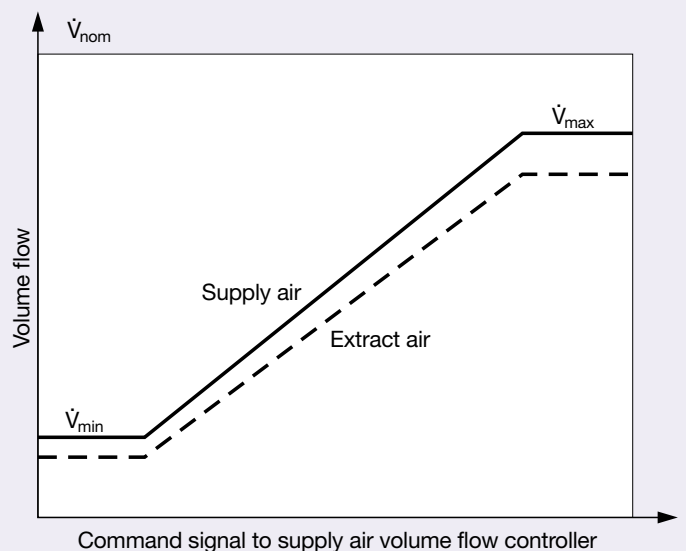

Construction · Dimensions

Characteristics

- Electronic volume flow control
- Suitable for supply or extract air
- Volume flow range (depending on manufacturer and type of controller) approx. 5 : 1
- High level of control accuracy for the volume flow settings, please ensure the most favourable aerodynamic configuration of ductwork is used
- Factory set up of volume flow or programming. This includes aerodynamic testing of each unit using a dedicated test rig. Data covering set up is given on a test label attached to each unit
- Volume flow can be measured and subsequently reset on site; an additional peripheral device may be necessary
- Actual value signal referred to \dot{V}_{nom}
- Differential pressure range 20 to 1000 Pa
- Horizontal or vertical installation (when using diaphragm pressure sensors, install according to label on the unit)
- Full shut-off from ductwork system
- TVT: Closed blade air leakage complies with EN 1751, class 4 (B > 600 class 3), also complies with the requirements of DIN 1946, part 4

- The units are, in terms of their mechanical parts, maintenance-free
- Operating temperature 10 to 50 °C

Constructional features

- Rectangular form, rigid frame
- Flanged at both ends, suitable for fitting System 30 connecting sections
- Opposed blade action, blades connected by internal gears at both ends
- Bearing inserts sealed with ring O rings

Casing

- Casing, spindles and linkage made of galvanized sheet steel
- Blades and differential pressure grid made from aluminium extruded profiles
- Gears made from antistatic plastic (ABS), heat-resistant to 50 °C

TVT damper

- Replaceable seals
- Totally enclosed internal gears

Continued on page 6

TVJ · TVT

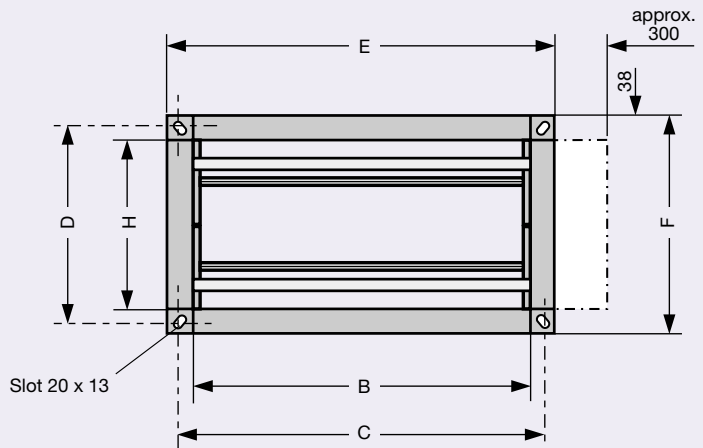
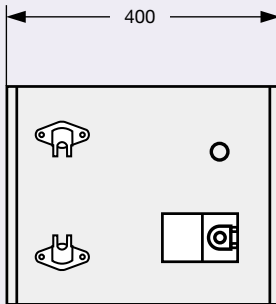

--- Keep clear to provide access to control components

TVJD · TVTD

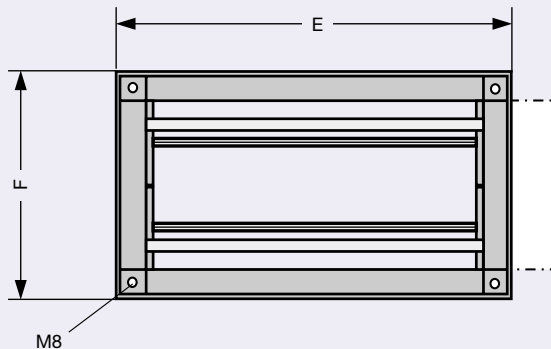
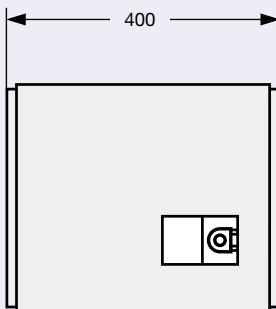

Rectangular duct connection see on page 6

Nomenclature · Shut-off position TVJ

Nomenclature

- f_m in Hz: Octave centre frequency
- L_W in dB: Sound power level of air-regenerated noise in the air duct
- L_{W1} in dB: Sound power level of air-regenerated noise with TX secondary silencer
- L_{W2} in dB: Sound power level of case radiated noise
- L_{W3} in dB: Sound power level of case radiated noise with additional acoustic cladding
- L_{WAL} in dB(A): A-weighted sound power level of air-regenerated noise in the connecting duct, control damper in the shut-off position (only on TVJ)
- L_{pA} in dB(A): A-weighted sound pressure level of air-regenerated noise, system attenuation taken into account
- L_{pA1} in dB(A): A-weighted sound pressure level of air-regenerated noise with TX secondary silencer, system attenuation taken into account
- L_{pA2} in dB(A): A-weighted sound pressure level of case-radiated noise, system attenuation taken into account
- L_{pA3} in dB(A): A-weighted sound pressure level of case-radiated noise with additional acoustic cladding, system attenuation taken into account

- ΔL_W in dB: Correction value for case radiated noise sound power level without additional acoustic cladding
- ΔL_{W1} in dB: Correction value for case radiated noise sound power level with additional acoustic cladding
- \dot{V}_{nom} in l/s or m³/h: Nominal volume flow (100 %)
- \dot{V} in l/s or m³/h: Volume flow
- $\Delta \dot{V}$ in \pm %: Volume flow tolerance from set point
- \dot{V}_L in l/s or m³/h: Leakage flow, TVJ control damper in shut-off position
- Δp_g in Pa: Static pressure differential
- $\Delta p_{g min}$ in Pa: Minimum static pressure differential
- B in mm: Width
- H in mm: Height

All sound powers levels are based on 1 pW, all sound pressure levels on 20 μ Pa.

All noise levels measured in a reverberation chamber. The sound power level data was determined and corrected according to DIN EN ISO 5135, February 1999.

Leakage flow and sound power level, TVJ in shut-off position

Dimensions B x H mm	$\Delta p_g = 100$ Pa			$\Delta p_g = 200$ Pa			$\Delta p_g = 500$ Pa		
	\dot{V}_L		L_{WAL} in dB(A)	\dot{V}_L		L_{WAL} in dB(A)	\dot{V}_L		L_{WAL} in dB(A)
	in l/s	in m ³ /h		in l/s	in m ³ /h		in l/s	in m ³ /h	
200 100	9	32	39	13	46	47	20	72	57
300	9	34	41	13	48	49	21	76	59
400	10	35	42	14	50	50	22	79	60
500	11	40	43	16	57	51	25	90	61
600	13	45	44	18	64	52	28	101	62
200 200	10	35	42	14	50	50	22	79	60
300	11	40	44	16	57	52	25	90	62
400	13	45	45	18	64	53	28	101	63
500	14	52	45	20	73	53	32	115	63
600	16	56	46	22	80	54	35	126	64
700	17	63	47	25	89	55	39	140	65
800	19	68	48	27	96	56	42	151	66
300 300	15	53	45	21	75	53	33	119	63
400	17	61	46	24	87	54	38	137	64
500	20	71	47	28	100	55	44	158	65
600	22	79	48	31	112	56	49	176	66
700	24	85	49	34	121	57	53	191	67
800	25	90	50	35	128	58	56	202	68
900	26	95	49	37	134	57	59	212	67
1000	27	98	50	39	139	58	61	220	68
400 400	22	80	48	32	114	56	50	180	66
500	25	90	49	35	128	57	56	202	67
600	27	98	50	39	139	58	61	220	68
700	30	109	49	43	155	57	68	245	67
800	34	121	50	47	171	58	75	270	68
900	35	127	51	50	180	59	79	284	69
1000	37	134	51	52	189	59	83	299	69
500 500	29	105	50	41	148	58	65	234	68
600	32	116	50	46	164	58	72	259	68
700	35	126	50	49	178	58	78	281	68
800	38	135	51	53	191	59	84	302	69
900	40	145	51	57	205	59	90	324	69
1000	43	155	52	61	219	60	96	346	70
600 600	36	129	51	51	182	59	80	288	69
800	44	158	52	62	223	60	98	353	70
1000	51	185	53	73	262	61	115	414	71
800 800	54	193	53	76	273	61	120	432	71
1000	65	233	54	92	330	62	145	522	72
1000 1000	76	274	55	108	387	63	170	612	73

TX Secondary Silencer

Additional acoustic cladding

- Outer cover in galvanized sheet steel
- Sound-absorbent lining
- Structure-borne sound insulation
- Cannot be retro-fitted

Air Heater

- Suitable for the TVJ/TVT unit
- See leaflet 5/20/EN/... for reheat coil dimensions and technical data

TX secondary silencer

- Suitable for the TVJ/TVT unit
- Casing in galvanized sheet steel
- Mineral wool lining conforming to DIN 4102, building material class A2, with RAL quality mark RAL-GZ 388, biodegradable as defined by TRGS 905 as well as EU Directive 97/69/EC
- Mineral wool faced with glass-fibre fabric providing protection against erosion by air flow up to a maximum air velocity of 20 m/s, inert to fungal and bacterial growth

TX

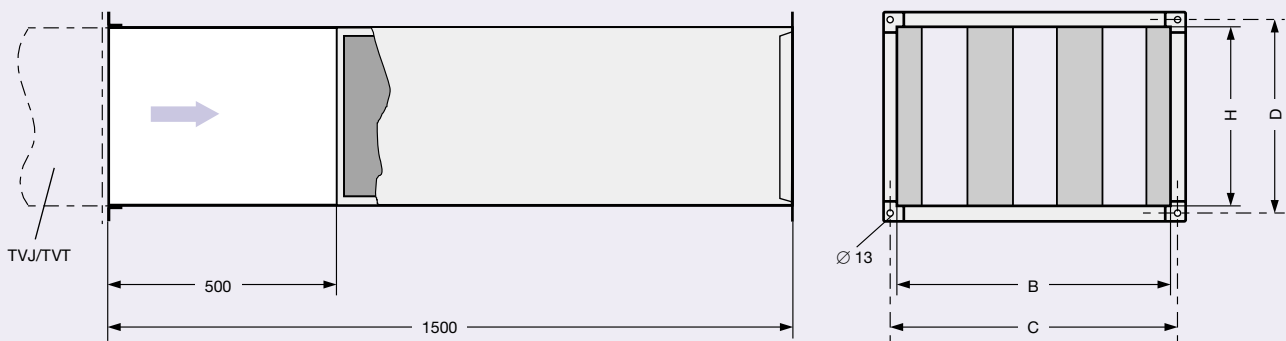

Rectangular duct connection

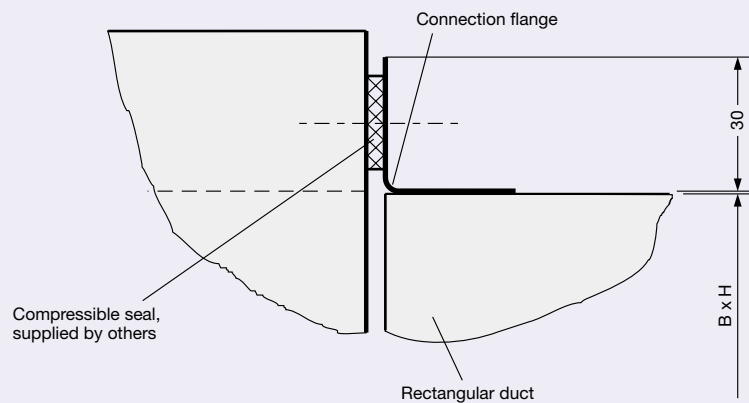

Dimensions

B x H mm		Dimensions in mm								Weights in kg		
		TVJ/TVT				TVJD/TVTD				TVJ/ TVT	TVJD/ TVTD	TX
		C	D	E	F	C	D	E	F			
200	100	234	134	276	176	234	134	280	180	6	9	10
	300	334	134	376	176	334	134	380	180	7	11	12
	400	434	134	476	176	434	134	480	180	8	12	15
	500	534	134	576	176	534	134	580	180	9	14	17
	600	634	134	676	176	634	134	680	180	10	15	20
200	200	234	234	276	276	234	234	280	280	9	14	16
	300	334	234	376	276	334	234	380	280	10	15	20
	400	434	234	476	276	434	234	480	280	11	17	25
	500	534	234	576	276	534	234	580	280	12	18	29
	600	634	234	676	276	634	234	680	280	13	20	34
	700	734	234	776	276	734	234	780	280	14	21	39
	800	834	234	876	276	834	234	880	280	15	23	44
300	300	334	334	376	376	334	334	380	380	10	15	24
	400	434	334	476	376	434	334	480	380	11	17	29
	500	534	334	576	376	534	334	580	380	12	18	34
	600	634	334	676	376	634	334	680	380	13	20	40
	700	734	334	776	376	734	334	780	380	15	22	45
	800	834	334	876	376	834	334	880	380	16	24	50
	900	934	334	976	376	934	334	980	380	18	26	55
	1000	1034	334	1076	376	1034	334	1080	380	19	29	60
400	400	434	434	476	476	434	434	480	480	14	21	34
	500	534	434	576	476	534	434	580	480	15	23	39
	600	634	434	676	476	634	434	680	480	16	24	45
	700	734	434	776	476	734	434	780	480	17	26	50
	800	834	434	876	476	834	434	880	480	18	27	56
	900	934	434	976	476	934	434	980	480	20	29	61
	1000	1034	434	1076	476	1034	434	1080	480	21	32	67
500	500	534	534	576	576	534	534	580	580	19	28	45
	600	634	534	676	576	634	534	680	580	20	30	50
	700	734	534	776	576	734	534	780	580	22	32	56
	800	834	534	876	576	834	534	880	580	23	35	62
	900	934	534	976	576	934	534	980	580	25	37	68
	1000	1034	534	1076	576	1034	534	1080	580	26	39	73
		TVJ				TVJD				TVJ	TVJD	TX
600	600	634	634	676	676	634	634	680	680	19	29	55
	800	834	634	876	676	834	634	880	680	23	35	67
	1000	1034	634	1076	676	1034	634	1080	680	27	41	80
800	800	834	834	876	876	834	834	880	880	28	42	79
	1000	1034	834	1076	876	1034	834	1080	880	32	48	93
1000	1000	1034	1034	1076	1076	1034	1034	1080	1080	38	57	107

Aerodynamic Data

H = 100 to 300

Volume flow ranges and minimum pressure differentials						
B x H mm	$\dot{V}^{1)}$		v m/s	$\Delta \dot{V}^{1)}$ ± %	$\Delta p_{g \min}$ in Pa	
	l/s	m ³ /h			TVJ/TVT	TX ²⁾
200 100	45	162	2	14	20	5
	85	306	4	8	20	20
	150	540	7	5	30	55
	215	774	10	5	40	115
300	65	234	2	14	20	5
	120	432	4	8	20	20
	210	756	7	5	30	55
	320	1152	10	5	40	115
400	85	306	2	14	20	5
	170	612	4	8	20	20
	300	1080	7	5	30	55
	425	1530	10	5	40	115
500	105	378	2	14	20	5
	200	720	4	8	20	20
	350	1260	7	5	30	55
	535	1926	10	5	40	115
600	130	468	2	14	20	5
	260	936	4	8	20	20
	450	1620	7	5	30	55
	650	2340	10	5	40	115
200 200	85	306	2	14	20	5
	160	576	4	8	20	20
	280	1008	7	5	30	55
	415	1494	10	5	40	115
300	125	450	2	14	20	5
	240	864	4	8	20	20
	420	1512	7	5	30	55
	620	2232	10	5	40	115
400	165	594	2	14	20	5
	330	1188	4	8	20	20
	580	2088	7	5	30	55
	825	2970	10	5	40	115
500	205	738	2	14	20	5
	400	1440	4	8	20	20
	700	2520	7	5	30	55
	1035	3726	10	5	40	115
600	250	900	2	14	20	5
	500	1800	4	8	20	20
	870	3132	7	5	30	55
	1250	4500	10	5	40	115
700	290	1044	2	14	20	5
	560	2016	4	8	20	20
	980	3528	7	5	30	55
	1450	5220	10	5	40	115
800	330	1188	2	14	20	5
	660	2376	4	8	20	20
	1160	4176	7	5	30	55
	1650	5940	10	5	40	115

Volume flow ranges and minimum pressure differentials						
B x H mm	$\dot{V}^{1)}$		v m/s	$\Delta \dot{V}^{1)}$ ± %	$\Delta p_{g \min}$ in Pa	
	l/s	m ³ /h			TVJ/TVT	TX ²⁾
300 300	185	666	2	14	20	5
	360	1296	4	8	20	20
	630	2268	7	5	25	55
	920	3312	10	5	35	115
400	245	882	2	14	20	5
	480	1728	4	8	20	20
	840	3024	7	5	25	55
	1230	4428	10	5	35	115
500	305	1098	2	14	20	5
	600	2160	4	8	20	20
	1050	3780	7	5	25	55
	1535	5526	10	5	35	115
600	370	1332	2	14	20	5
	740	2664	4	8	20	20
	1290	4644	7	5	25	55
	1850	6660	10	5	35	115
700	430	1548	2	14	20	5
	840	3024	4	8	20	20
	1470	5292	7	5	25	55
	2150	7740	10	5	35	115
800	490	1764	2	14	20	5
	980	2528	4	8	20	20
	1720	6192	7	5	25	55
	2450	8820	10	5	35	115
900	555	1998	2	14	20	5
	1080	3888	4	8	20	20
	1890	6804	7	5	25	55
	2770	9972	10	5	35	115
1000	620	2234	2	14	20	5
	1240	4464	4	8	20	20
	2150	7740	7	5	25	55
	3100	11160	10	5	35	115

1) Typical values

2) Additional pressure to be taken into account

Aerodynamic Data

H = 400 to 1000

Volume flow ranges and minimum pressure differentials						
B x H mm	$\dot{V}^{1)}$		v m/s	$\Delta \dot{V}^{1)}$ ± %	$\Delta p_{g \min}$ in Pa	
	l/s	m ³ /h			TVJ/TVT	TX ²⁾
400 400	325	1170	2	14	20	5
	640	2304	4	8	20	20
	1120	4032	7	5	25	55
	1630	5868	10	5	35	115
500	410	1476	2	14	20	5
	800	2880	4	8	20	20
	1400	5040	7	5	25	55
	2040	7344	10	5	35	115
600	490	1764	2	14	20	5
	980	2528	4	8	20	20
	1720	6192	7	5	25	55
	2450	8820	10	5	35	115
700	570	2052	2	14	20	5
	1120	4032	4	8	20	20
	1960	7056	7	5	25	55
	2850	10260	10	5	35	115
800	650	2340	2	14	20	5
	1300	4680	4	8	20	20
	2280	8208	7	5	25	55
	3250	11700	10	5	35	115
900	735	2646	2	14	20	5
	1440	5184	4	8	20	20
	2520	9072	7	5	25	55
	3670	13212	10	5	35	115
1000	820	2952	2	14	20	5
	1640	5904	4	8	20	20
	2850	10260	7	5	25	55
	4100	14760	10	5	35	115
500 500	510	1836	2	14	20	5
	1000	3600	4	8	20	20
	1750	6300	7	5	30	55
	2540	9144	10	5	40	115
600	610	2196	2	14	20	5
	1200	4320	4	8	20	20
	2100	7560	7	5	30	55
	3050	10980	10	5	40	115
700	710	2556	2	14	20	5
	1400	5040	4	8	20	20
	2450	8820	7	5	30	55
	3550	12780	10	5	40	115
800	810	2916	2	14	20	5
	1600	5760	4	8	20	20
	2800	10080	7	5	30	55
	4050	14580	10	5	40	115
900	915	3294	2	14	20	5
	1800	6480	4	8	20	20
	3150	11340	7	5	30	55
	4570	16452	10	5	40	115
1000	1020	3672	2	14	20	5
	2000	7200	4	8	20	20
	3500	12600	7	5	30	55
	5100	18360	10	5	40	115

Volume flow ranges and minimum pressure differentials						
B x H mm	$\dot{V}^{1)}$		v m/s	$\Delta \dot{V}^{1)}$ ± %	$\Delta p_{g \min}$ in Pa	
	l/s	m ³ /h			TVJ/TVT	TX ²⁾
600 600	730	2628	2	14	20	5
	1440	5184	4	8	20	20
	2520	9072	7	5	30	55
	3650	13140	10	5	40	115
	970	3492	2	14	20	5
800	1920	6912	4	8	20	20
	3360	12096	7	5	30	55
	4850	17460	10	5	40	115
	1220	4392	2	14	20	5
1000	2400	8640	4	8	20	20
	4200	15120	7	5	30	55
	6100	21960	10	5	40	115
	1300	4680	2	14	20	5
800 800	2560	9216	4	8	20	20
	4480	16128	7	5	30	55
	6500	23400	10	5	40	115
	1620	5832	2	14	20	5
1000	3200	11520	4	8	20	20
	5600	20160	7	5	30	55
	8100	29160	10	5	40	115
	2020	7272	2	14	20	5
1000 1000	4000	14400	4	8	20	20
	7000	25200	7	5	30	55
	10100	36360	10	5	40	115

1) Typical values 2) Additional pressure to be taken into account

Acoustic Quick Selection

System attenuation in dB/octave in accordance with VDI 2081 (taken into account in the quick selection table)

f_m in Hz	63	125	250	500	1000	2000	4000	8000
Duct bend attenuation	0	0	1	2	3	3	3	3
Room attenuation	5	5	5	5	5	5	5	5
End reflection	10	5	2	0	0	0	0	0

Correction for distribution into the low pressure duct system (taken into account in the quick selection table)

\dot{V}	l/s	150	300	600	1500	3000	4500	6000	7000	8000	9000	10000
	m ³ /h	540	1080	2160	5400	10800	16200	21600	25200	28800	32400	36000
dB per octave		0	3	6	10	13	14	16	17	17	18	19

Correction for other widths

Δp_g	Widths B	Reference B = 600 mm									Reference B = 1000 mm		
		200	300	400	500	600	700	800	900	1000	800	900	1000
100 Pa	100 Pa	-4	-2	-2	-1	0	1	1	1	2	-1	-1	0
	200 Pa	-4	-3	-2	-1	0	1	1	2	2	-1	0	0
	500 Pa	-4	-2	-1	-1	0	1	1	2	3	-1	-1	0

Quick selection table – sound pressure level in dB(A)

B x H mm	v m/s	$\Delta p_g = 100$ Pa				$\Delta p_g = 200$ Pa				$\Delta p_g = 500$ Pa				
		Air-regenerated noise		Case-radiated noise ¹⁾		Air-regenerated noise		Case-radiated noise ¹⁾		Air-regenerated noise		Case-radiated noise ¹⁾		
		L_{pA}	L_{pA1}	L_{pA2}	L_{pA3}	L_{pA}	L_{pA1}	L_{pA2}	L_{pA3}	L_{pA}	L_{pA1}	L_{pA2}	L_{pA3}	
		without silencer	with silencer TX	without acoustic cladding	with acoustic cladding	without silencer	with silencer TX	without acoustic cladding	with acoustic cladding	without silencer	with silencer TX	without acoustic cladding	with acoustic cladding	
600	100	2	43	20	30	19	49	23	35	24	60	32	46	33
		4	44	26	34	26	50	29	39	30	60	36	48	37
		7	44	32	39	33	51	35	43	35	59	40	51	42
		10	45	39	43	37	51	40	46	39	59	44	54	47
	200	2	43	20	32	22	49	24	38	26	60	32	48	35
		4	43	25	37	29	50	29	42	33	59	36	50	40
		7	44	32	42	36	50	35	46	39	58	41	54	46
		10	44	39	45	40	50	40	49	43	58	45	57	50
	300	2	42	20	33	23	49	24	39	28	60	32	49	37
		4	43	25	38	31	49	29	44	35	59	37	52	42
		7	43	32	43	37	50	35	48	41	58	42	56	48
		10	44	39	47	42	50	40	51	45	58	45	60	52
400	2	42	19	34	24	49	24	40	29	60	32	50	38	
	4	43	24	39	32	49	29	45	36	58	37	53	43	
	7	43	32	45	39	49	35	49	42	58	43	58	50	
	10	44	39	49	43	48	40	50	43	59	46	62	54	
500	2	42	19	35	25	48	24	41	30	59	32	51	39	
	4	42	24	40	33	49	29	46	37	58	38	55	45	
	7	43	32	46	40	49	35	50	43	58	43	59	51	
	10	44	39	50	44	48	40	51	44	59	46	63	56	
600	2	42	19	36	26	48	24	42	31	59	32	52	40	
	4	42	24	41	34	49	29	46	38	58	38	55	46	
	7	43	32	46	41	49	35	51	44	58	43	60	52	
	10	44	39	50	45	48	40	52	45	59	47	64	57	
1000	800	2	41	18	39	30	48	24	45	35	59	34	55	44
		4	42	23	45	38	48	29	50	42	58	40	60	51
		7	43	31	50	45	49	35	55	48	59	45	66	58
	10	44	39	54	49	47	40	55	49	61	48	70	63	
1000	2	41	18	40	31	47	24	46	36	58	35	56	45	
	4	42	23	46	39	48	29	51	43	58	41	62	53	
	7	43	31	51	46	48	35	56	49	59	46	68	60	
	10	44	39	56	50	47	40	56	50	61	49	72	64	

1) 4 dB/octave ceiling reduction and 5 dB/octave room attenuation have been allowed for in the calculation of radiated noise.

Air-regenerated Noise with TX secondary silencer

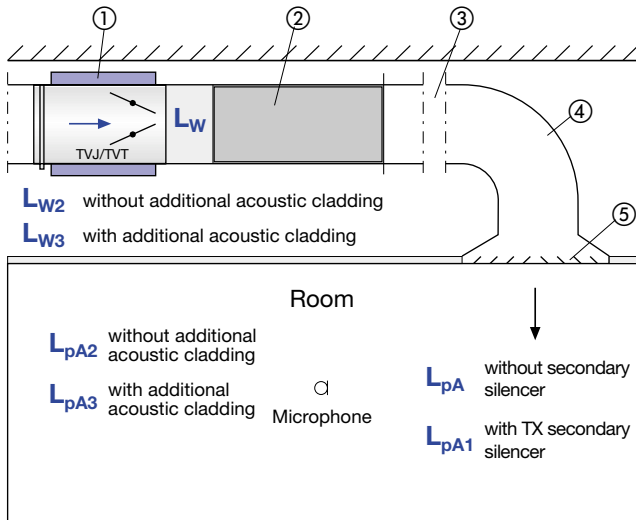

Nomenclature, see page 5

Air-regenerated noise with TX secondary silencer

B x H mm	v m/s	$\Delta p_g = 100 \text{ Pa}$								$\Delta p_g = 200 \text{ Pa}$								$\Delta p_g = 500 \text{ Pa}$								
		L_{w1} in dB								L_{w1} in dB								L_{w1} in dB								
		f_m in Hz								f_m in Hz								f_m in Hz								
		63	125	250	500	1000	2000	4000	8000	63	125	250	500	1000	2000	4000	8000	63	125	250	500	1000	2000	4000	8000	
600	100	2	44	42	34	17	5	0	0	9	48	44	36	21	9	7	10	23	54	48	41	27	16	17	26	39
		4	53	50	40	29	24	20	16	19	57	53	43	33	26	24	24	30	62	58	50	37	30	29	34	42
		7	59	57	45	39	40	35	31	26	64	60	49	42	40	37	35	35	69	66	57	44	41	38	40	45
		10	64	62	48	45	50	45	40	31	68	64	53	48	49	46	43	39	73	71	61	49	48	45	44	46
	200	2	48	43	37	19	8	4	2	11	52	47	40	24	12	10	13	23	59	52	46	30	19	20	28	39
		4	56	52	43	31	27	23	20	20	60	56	47	36	30	27	27	31	67	62	55	40	33	32	35	42
		7	63	59	47	41	43	39	34	28	68	63	52	45	44	41	38	36	73	70	62	48	44	42	41	44
	300	2	50	44	38	20	9	6	4	12	54	49	42	26	14	12	14	24	61	55	49	32	21	22	29	38
		4	59	53	44	32	29	25	22	22	63	58	49	37	31	29	28	31	69	65	58	42	35	34	36	41
		7	65	60	49	42	44	41	36	29	70	64	54	46	45	43	39	37	76	73	65	50	46	44	42	44
	400	2	52	45	39	21	11	8	5	13	56	50	43	27	15	14	15	24	63	56	51	34	23	23	29	38
		4	60	54	45	33	30	27	23	22	64	59	50	38	33	31	29	31	71	66	60	44	36	36	37	41
7		67	61	50	43	45	43	37	30	71	66	56	48	47	44	40	37	78	74	67	51	48	45	43	44	
500	2	53	46	40	22	11	9	7	14	57	51	44	28	16	15	16	25	65	58	53	35	24	25	30	38	
	4	61	54	46	34	31	28	24	23	65	60	51	39	34	32	30	32	73	68	61	45	38	37	38	41	
	7	68	61	51	44	46	44	38	30	73	67	57	48	48	45	41	38	79	76	69	53	49	46	44	44	
600	2	54	46	41	22	12	10	7	14	58	52	45	28	17	16	16	25	66	59	54	36	25	26	30	38	
	4	62	55	47	34	32	29	25	23	66	61	52	40	35	32	30	32	74	69	63	46	38	38	38	41	
	7	69	62	51	44	47	45	39	31	74	68	57	49	49	46	42	38	81	77	70	53	50	47	44	43	
1000	800	2	58	48	44	24	16	14	11	16	62	56	48	31	21	20	19	26	71	63	60	40	28	29	32	37
		4	67	57	50	37	35	33	29	26	71	64	56	43	38	36	33	33	79	73	69	50	42	42	40	40
		7	74	64	54	46	51	49	43	33	78	71	61	52	52	50	44	39	86	81	76	58	53	51	46	43
		10	78	68	57	53	60	59	52	38	82	75	65	58	61	58	51	42	90	87	80	63	60	57	50	44
	1000	2	60	49	45	25	17	15	12	17	63	57	50	32	22	21	20	26	73	65	61	41	29	31	33	37
		4	68	57	50	37	36	34	30	26	72	65	57	44	39	38	34	33	81	75	70	51	43	43	40	40
		7	75	64	55	47	51	50	44	34	79	72	62	53	53	51	45	39	88	83	77	59	54	52	47	43
		10	79	69	58	53	61	60	53	39	84	76	66	59	62	60	52	43	92	88	82	64	62	59	50	44

See page 10 for correction to other widths.

For acoustic data for differential pressure up to 1000 Pa, see on-line design programme "Air terminal units".

Air-regenerated Noise

without secondary silencer

Correction for other widths																										
related to	Width	$\Delta p_g = 100 \text{ Pa}$								$\Delta p_g = 200 \text{ Pa}$								$\Delta p_g = 500 \text{ Pa}$								
		63	125	250	500	1000	2000	4000	8000	63	125	250	500	1000	2000	4000	8000	63	125	250	500	1000	2000	4000	8000	
B = 600	200	-8	-4	-6	-2	-2	-5	-4	-6	-5	-6	-6	-3	-3	-4	-3	-4	-6	-5	-10	-5	-3	-4	-3	-3	
	300	-5	-3	-4	-1	-1	-3	-3	-4	-3	-4	-4	-2	-2	-3	-2	-3	-4	-3	-6	-3	-2	-3	-2	-2	
	400	-3	-2	-2	-1	-1	-2	-2	-2	-2	-2	-2	-1	-1	-2	-1	-1	-2	-2	-4	-2	-1	-2	-1	-1	
	500	-1	-1	-1	0	0	-1	-1	-1	-1	-1	-1	0	0	-1	-1	-1	-1	-1	-1	-2	-1	0	-1	0	-1
	600	0	0	0	0	0	0	0	0	0	0	0	0	0	0	0	0	0	0	0	0	0	0	0	0	0
	700	1	1	1	0	0	1	1	1	1	1	1	1	0	0	1	0	1	1	1	1	1	0	1	0	0
	800	2	1	2	0	1	1	1	2	1	1	2	1	1	1	1	1	1	2	1	3	1	1	1	1	1
	900	3	2	2	1	1	2	2	2	2	2	2	1	1	2	1	1	2	2	4	2	1	2	1	1	1
	1000	4	2	3	1	1	2	2	3	3	3	3	1	1	2	2	2	3	2	4	2	1	2	1	2	2
B = 1000	800	-2	-1	0	-1	-1	-1	-1	-1	-1	-1	-1	-1	-1	-1	-1	-1	-1	-1	-1	-2	-1	-1	-1	-1	
	900	-1	-1	0	-1	0	0	-1	-1	-1	-1	0	0	0	0	0	0	-1	-1	0	-1	0	0	0	0	
	1000	0	0	0	0	0	0	0	0	0	0	0	0	0	0	0	0	0	0	0	0	0	0	0	0	

Air-regenerated noise without secondary silencer																										
B x H	v	$\Delta p_g = 100 \text{ Pa}$								$\Delta p_g = 200 \text{ Pa}$								$\Delta p_g = 500 \text{ Pa}$								
		L_w in dB								L_w in dB								L_w in dB								
		f_m in Hz								f_m in Hz								f_m in Hz								
mm	m/s	63	125	250	500	1000	2000	4000	8000	63	125	250	500	1000	2000	4000	8000	63	125	250	500	1000	2000	4000	8000	
600	100	2	45	46	42	44	46	46	39	32	52	49	46	48	51	53	49	45	57	53	49	53	59	64	63	59
		4	55	56	49	47	49	49	43	37	61	58	53	52	54	56	52	49	65	63	58	59	62	65	64	61
		7	63	63	54	50	51	51	47	41	68	65	58	56	57	58	55	52	72	71	66	63	64	66	65	63
		10	68	68	57	52	53	53	49	43	72	70	62	58	59	59	57	54	76	77	70	66	66	66	66	64
	200	2	51	49	46	45	48	49	41	36	56	53	49	50	52	56	51	47	60	56	55	56	61	66	65	61
		4	60	58	53	48	50	52	46	41	64	61	56	54	56	58	54	51	69	66	64	62	64	67	66	63
		7	68	66	58	51	53	54	50	45	71	69	62	58	59	61	57	54	76	74	72	66	66	68	67	65
		10	73	71	61	53	54	56	52	47	75	73	66	60	61	62	59	56	80	80	76	69	67	69	68	66
	300	2	53	51	48	45	48	51	43	38	58	55	51	51	53	57	52	49	63	58	59	58	62	68	66	62
		4	63	60	55	49	51	54	47	43	66	64	58	55	57	60	56	53	71	68	68	63	64	69	67	65
		7	71	68	60	51	53	56	51	47	73	71	64	59	60	62	59	56	78	76	75	68	67	70	68	66
		10	76	73	63	53	55	58	53	50	77	75	68	61	61	64	60	58	82	81	80	71	68	70	69	68
400	2	56	52	50	46	49	52	44	40	59	56	53	51	54	58	53	50	64	59	61	59	62	69	67	63	
	4	65	61	56	49	52	55	49	45	68	65	60	56	57	61	56	54	73	69	70	65	65	70	68	65	
	7	73	69	62	52	54	57	52	49	75	72	66	59	60	63	59	57	80	77	78	69	68	71	69	67	
	10	78	74	65	53	55	59	55	51	79	77	69	62	62	65	61	59	84	83	82	72	69	71	69	69	
500	2	57	53	51	46	49	53	45	41	60	57	54	52	54	59	53	51	66	60	63	60	63	70	67	64	
	4	67	62	58	49	52	56	49	46	69	66	61	56	58	62	57	55	74	70	72	65	66	71	68	66	
	7	75	70	63	52	54	58	53	50	76	73	67	60	61	64	60	58	81	78	80	70	68	72	69	68	
	10	79	75	66	54	56	60	55	53	80	78	71	62	63	66	62	60	85	84	84	73	70	72	70	69	
600	2	59	53	52	46	50	54	45	42	61	58	55	52	55	60	54	51	67	61	65	61	63	70	68	64	
	4	68	63	59	50	52	57	50	47	70	67	62	57	58	63	58	55	75	71	74	66	66	71	69	67	
	7	76	71	64	52	55	59	54	51	77	74	68	61	61	65	61	58	82	79	81	71	69	72	70	69	
	10	81	75	67	54	56	60	56	54	81	79	72	63	63	66	63	60	86	84	86	73	70	73	70	70	
1000	800	2	64	57	56	47	51	57	49	47	65	62	59	55	57	63	57	54	71	64	72	64	65	73	70	67
		4	74	66	63	51	54	60	53	52	74	71	67	59	60	66	60	58	80	74	81	70	68	75	71	69
		7	82	74	68	53	56	62	57	56	80	79	72	63	63	68	63	61	87	83	88	74	70	75	72	71
		10	87	79	71	55	57	64	59	58	85	83	76	65	65	69	65	63	91	88	93	77	72	76	73	72
1000	2	66	57	58	48	51	58	49	48	66	64	61	55	57	64	57	55	72	65	74	65	66	74	70	68	
	4	76	67	64	51	54	61	54	53	75	72	68	60	61	67	61	59	81	75	83	71	69	75	72	70	
	7	83	75	69	54	56	63	58	57	82	80	73	63	64	69	64	62	88	84	90	75	71	76	73	72	
	10	88	80	73	55	58	65	60	59	86	84	77	66	65	70	66	64	92	89	95	78	72	77	73	73	

For acoustic data for differential pressure up to 1000 Pa, see on-line design programme "Air terminal units".

Case-radiated Noise

Example

Given: $V_{max} = 400 \text{ l/s}$ resp. $1440 \text{ m}^3/\text{h}$, corresponds to 4 m/s
 $\Delta p_g = 500 \text{ Pa}$
 Specified sound pressure level in the room 40 dB(A) .
 See calculation method for further assumptions.

Calculation procedure

Quick selection:
 TVJ 500 x 200

Air-regenerated noise:
 $L_{pA} = 59 - 1 = 58 \text{ dB(A)}$

Specification is not met, so TX secondary silencer required
 TVJ 500 x 200 with TX secondary silencer
 $L_{pA1} = 36 - 1 = 35 \text{ dB(A)}$

Case-radiated noise:
 $L_{pA2} = 50 - 1 = 49 \text{ dB(A)}$
 Specification is not met, so additional acoustic cladding required
 TVJD 500 x 200 with TX secondary silencer
 $L_{pA3} = 40 - 1 = 39 \text{ dB(A)}$

Case-radiated noise calculation method

f_m	63	125	250	500	1000	2000	4000	8000
L_W (page 12, 600 x 200, 4 m/s)	69	66	64	62	64	67	66	63
Correction B = 500 (page 12)	-1	-1	-2	-1	0	-1	0	-1
ΔL_{W1}	7	7	14	21	25	28	28	25
L_{W3}	61	58	48	40	39	38	38	37
Ceiling reduction	4	4	4	4	4	4	4	4
Room attenuation	6	6	5	5	4	4	4	4
A-weighting	-26	-16	-9	-3	0	1	1	-1
Corrected level	25	32	30	28	31	31	31	28

Result: $L_{pA3} = 39 \text{ dB(A)}$

In a variation from the quick selection, different room attenuation values have been assumed. However, the result remains within the requirement.

Correction values for case-radiated noise

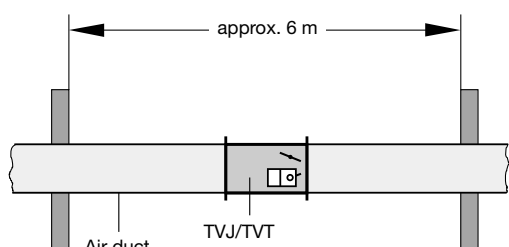
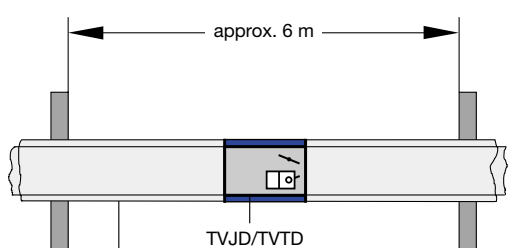
Installation location	$\Delta L_W / \Delta L_{W1}$	$\Delta L_W / \Delta L_{W1}$ in dB, related to f_m in Hz							
		63	125	250	500	1000	2000	4000	8000
TVJ/TVT $L_{W2} = L_W - \Delta L_W$ 	ΔL_W	3	3	6	9	12	14	15	14
TVJD/TVTD $L_{W3} = L_W - \Delta L_{W1}$ 	ΔL_{W1}	7	7	14	21	25	28	28	25

Order Details

Specification text *

Rectangular VAV control unit for variable volume systems, for supply air or extract air, in 39 sizes. Consists of a casing with damper blade, differential pressure sensor, and control components. The position of the damper blade is visible on the shaft from outside of the unit.

Special features:

- Averaging differential pressure sensor with 3 mm measuring holes, totally resistant to contamination
- Factory set up of volume flow or programming. Aerodynamic testing of each unit using a dedicated test rig. Data covering set up is on a test label attached to each case
- The actual value signal related to V_{nom} , allowing easier operation and retrospective volume flow rate adjustment

Casing flanged at both ends, TVT: Closed blade air leakage complies with EN 1751, class 4 (B > 600 class 3), also complies with the requirements of DIN 1946, part 4.

Differential pressure range 20 to 1000 Pa, volume flow range depending on make of controller approximately 5 : 1.

Control:

- Variable volume flow control, electronic controller for the connection of the control signal, actual value signal related to V_{nom} can be read
- Supply voltage 24 VAC
- Signal voltages from 0 to 10 VDC
- Dynamic differential pressure measurement

Materials:

- Casing, spindles and linkage made of galvanized sheet steel
- Blades and differential pressure grid made from aluminium extruded profiles
- Gears made from antistatic plastic (ABS), heat-resistant to 50 °C

Unit variant with:

Additional acoustic cladding, to reduce case-radiated noise. Consists of 40 mm mineral wool and outer cover of galvanised sheet steel. This gives a reduction in case-radiated noise of minimum 6 dB providing the upstream and downstream ducting has a rigid external insulation. Non-retrofitable.

Optionally with:

TX secondary silencer, for the reduction of air regenerated noise, insertion loss approx. 9 dB at 250 Hz. Lining of mineral wool conforming to DIN 4102, building material class A2, with RAL-quality mark RAL-GZ 388, bio-degradable pursuant to TRGS 905 and EU Directive 97/69/EG. Mineral wool faced with fibreglass as protection against erosion, suitable for air velocities up to 20 m/s, inert to fungal and bacterial growth.

* Text for basic construction; for the control components, see the design program or price list

TVJ/TVT Order codes

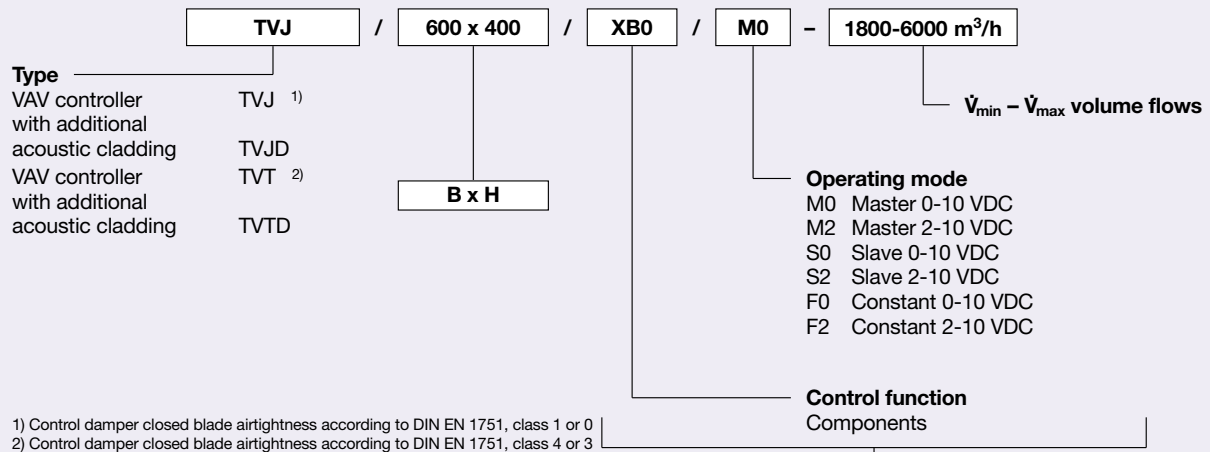

See design program or price list

TX Order codes

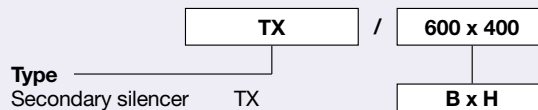

TVJ order example

Make: TROX
Type: TVJ / 600 x 400 / XB0 / M0 - 1800-6000 m³/h

TX order example

Make: TROX
Type: TX / 600 x 400