

Dehumidifier Consorb **CS-5, 5L**



Dehumidifying capacity at 20°C / 60%RH

0.35 - 0.4 kg/h

Dry air flow

65 - 90 m³/h

- Easy to place
- Very low sound-level
- Low weight
- Washable rotor
- No desiccant carry-over
- Stainless steel chassis
- Self-regulating heater
- Easy to maintain
- Long lifetime



Section of a dehumidifier rotor from Seibu Giken. The high number of channels means that moisture is adsorbed with extra efficiency.

World leaders in dehumidification.

TECHNICAL DATA

Dehumidifier model	CS-5	CS-5L
Nominal capacity ¹ (kg/h)	0.35	0.4
Dry air flow ² (m ³ /h)	65	90
at external static pressure (Pa)	50	100
Wet air flow ² (m ³ /h)	30	50
at external static pressure (Pa)	30 ³	30 ³
Heater current ³ [A]	2.8	3.5
Total power (kW)	0.7	0.85
Supply fuse 230V / 50Hz (A)	10	10
Weight (kg)	9	9

- 1 Valid for inlet conditions 20°C / 60%RH.
- 2 Volume flow for density 1.20 kg/m³.
- 3 The design of the PTC heater enables the power to be regulated by controlling the wet air flow.

PRINCIPLE

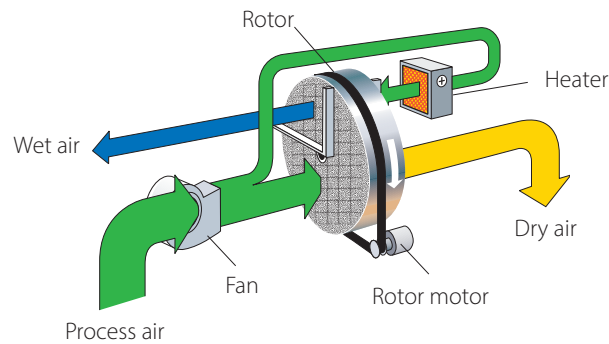

DIMENSIONS

Subject to change without notice. Download installation drawing at www.dst-sg.com

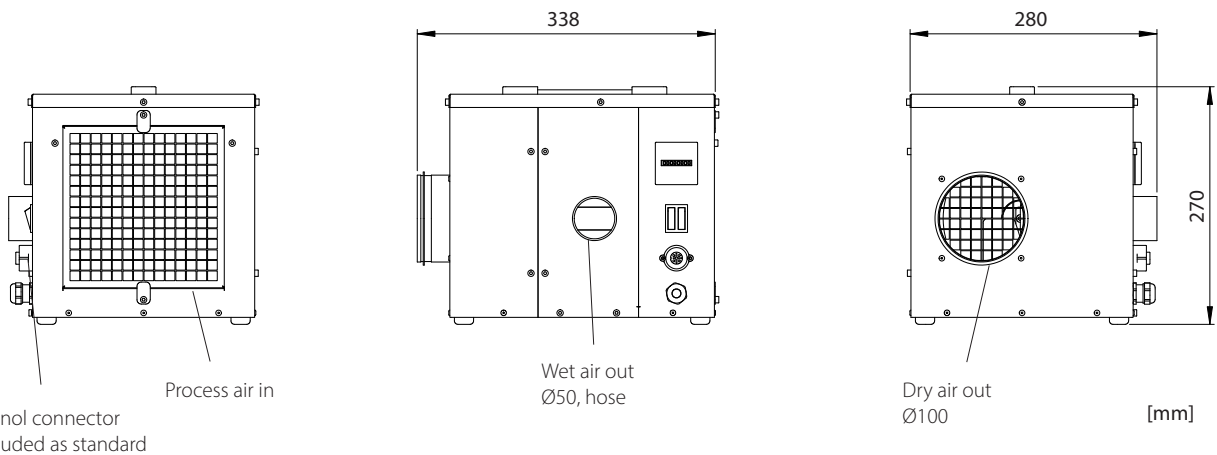

Updated 18.12



Sweden | +46 8 445 77 20
info@dst-sg.com | www.dst-sg.com