

Dehumidifier Consorb DC-10



Dehumidifying capacity at 20°C / 60%RH

0.6 kg/h

Dry air flow

190 m³/h

- Washable rotor
- No desiccant carry-over
- Stainless steel chassis
- Self-regulating heater
- Easy to maintain
- Long lifetime



Section of a dehumidifier rotor from Seibu Giken. The high number of channels means that moisture is adsorbed with extra efficiency.

World leaders in dehumidification.

TECHNICAL DATA

Dehumidifier model	DC-10
Nominal capacity ¹ (kg/h)	0.6
Dry airflow ² (m ³ /h)	190
Normal wet air flow ² (m ³ /h)	60
Heater current ³ (A)	4.5
Maximum electric consumption (kW)	1.3
Supply fuse 230V / 50Hz (A)	10
Weight (kg)	15

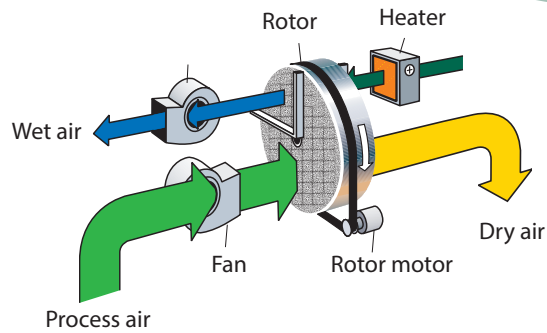

1. Valid for inlet conditions 20°C/60%RH. For other inlet conditions the capacity can be calculated by using the correction factor from the diagram shown below.
2. Volume flow for density 1.20 kg/m³. Free blowing.
3. The design of the PTC heater enables the power to be regulated by controlling the wet air flow.

CORRECTION DIAGRAM

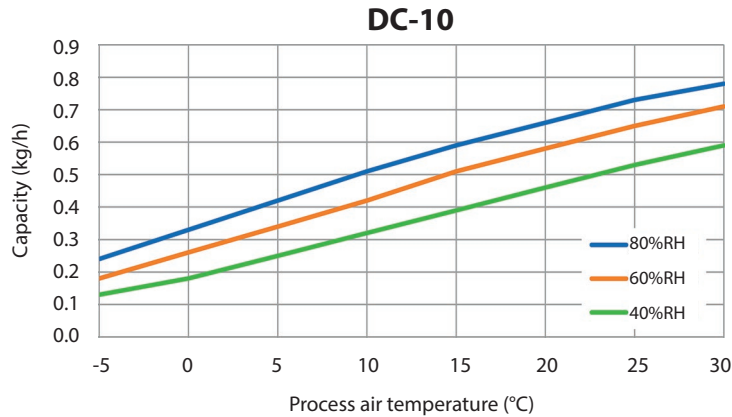

DIMENSIONS

Subject to change without notice. Download installation drawing at www.dst-sg.com

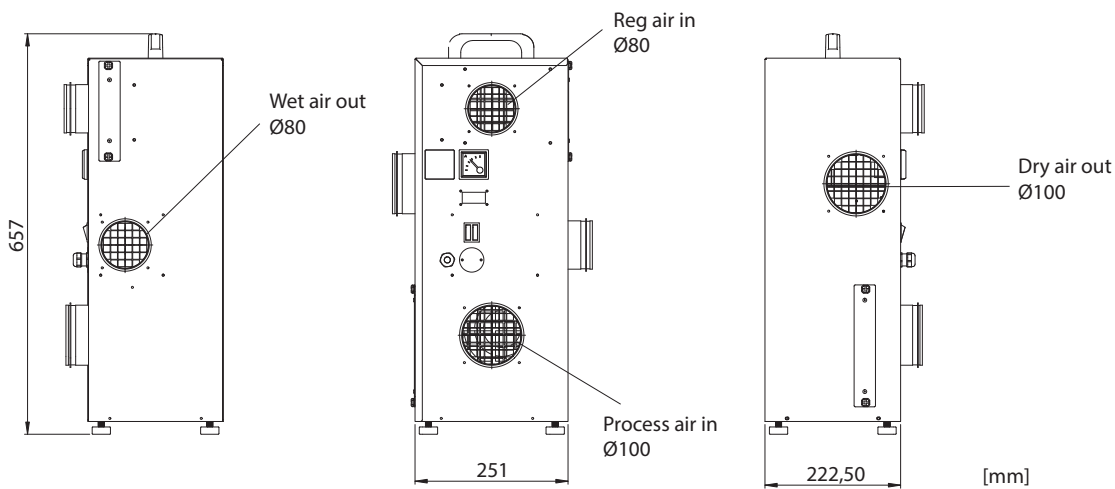

Updated 18.12



Sweden | +46 8 445 77 20
info@dst-sg.com | www.dst-sg.com