

# Dehumidifier Recusorb

# RL-61, -61 ICE, -61L, -61L ICE



*Dehumidifying capacity at 20°C / 60%RH*

**7.5 - 11.5 kg/h**

*Dry air flow*

**1300 - 2100 m<sup>3</sup>/h**

- Excellent performance in all climates
- Built-in heat recovery
- Duct connection
- F7 filter
- Stainless steel chassis and panels
- Highly efficient D-MAX rotor
- Options:
  - Frequency inverter to control airflows
  - Filter guard
  - Linear capacity control
  - Panel mounted humidity / dew point controller
  - Insulated inlets to help prevent condensation



*Section of a dehumidifier rotor from Seibu Giken. The high number of channels means that moisture is adsorbed with extra efficiency.*

*World leaders in dehumidification.*

# TECHNICAL DATA

Dehumidifier model	RL-61	RL-61 ICE	RL-61L	RL-61L ICE
Nominal capacity <sup>1</sup> (kg/h)	7.5	8	11	11.5
Dry air flow <sup>2</sup> (m <sup>3</sup> /h)	1300	1600	1800	2100
Static pressure at disposal (Pa)	200	400	200	300
Wet air flow <sup>2</sup> (m <sup>3</sup> /h)	280	280	420	420
Static pressure at disposal (Pa)	300	300	300	300
Heater power (kW)	9	9	13.5	13.5
Total power (kW)	10.2	10.9	15.6	16.3
Supply fuse 3 x 400V 50Hz (A)	20	20	25	32
Weight (kg)	130	130	132	132

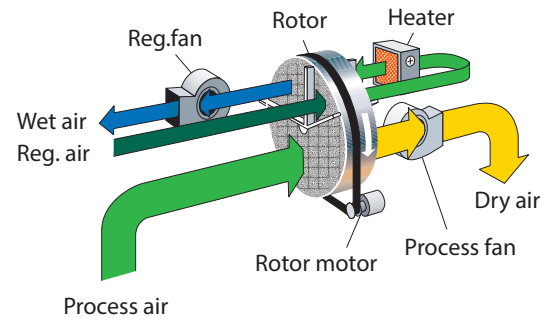

- Valid for inlet conditions 20°C/60%RH. For other inlet conditions the capacity can be calculated by using the correction diagrams shown below.
- Volume flow for density 1.20 kg/m<sup>3</sup>.

# CORRECTION DIAGRAM

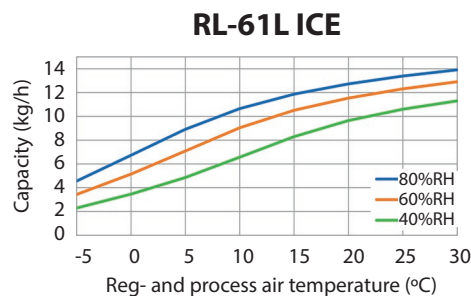
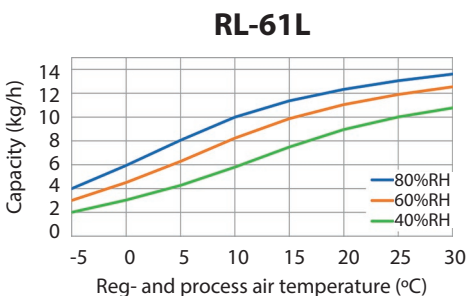
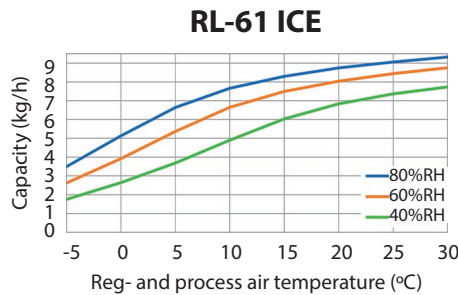
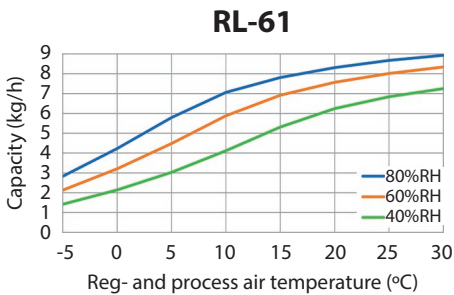

The temperature of the dry air at nominal air flows is calculated by: (Where C is the capacity in kg/h from above diagram).

**RL-61:**

$$T_{out} = T_{in} + C \times 1,6 + 3$$

**RL-61 ICE:**

$$T_{out} = T_{in} + C \times 1,3 + 3$$

**RL-61L:**

$$T_{out} = T_{in} + C \times 1,2 + 3$$

**RL-61L ICE:**

$$T_{out} = T_{in} + C + 3$$

# DIMENSIONS

Subject to change without notice. Download installation drawing at [www.dst-sg.com](http://www.dst-sg.com)

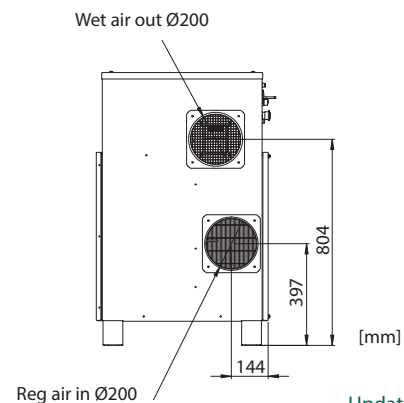
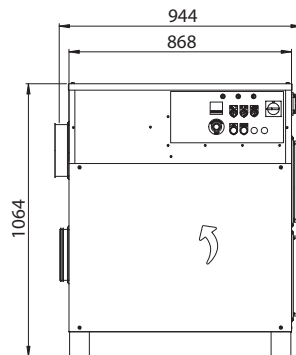
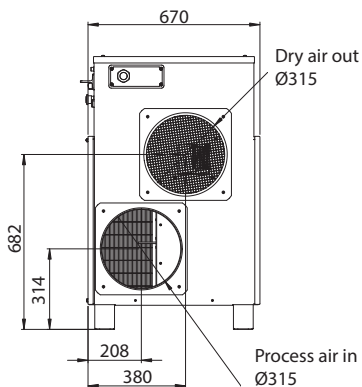

Updated 18.12



Sweden | +46 8 445 77 20  
info@dst-sg.com | www.dst-sg.com