



**ThermoKey®**  
Heat Exchange Solutions

V-Tower

# V-Tower

Evaporative Panel System  
Dry Cooler



## INDUSTRIAL HIGHLIGHTS



### NO AEROSOL

Cooling system similar to the cooling tower one, yet with no aerosol set of problems



### HIGHER SPECIFIC CAPACITY

Adiabatic system with evaporative panels to reach higher specific capacity compared to a traditional Dry Cooler



### COMPLETE CONTROL

Optimisation and complete control of the adiabatic system



### SMART MODULARITY

Smart modularity of the system to obtain maximum simplicity in use and reliability

# The EPS adiabatic system

## ADIABATIC SYSTEM: HOW IT WORKS

The physical principle is the latent heat of evaporation - when evaporating the water absorbs heat from the air entering in the heat exchanger and lowers its temperature.

The adiabatic system applied to dry-coolers and large remote condensers or gas-coolers is activated in order to reduce the air inlet temperature and increase the heat exchange.

ThermoKey has developed different adiabatic systems to be effective and efficient under certain environmental conditions.

## BESPOKE SYSTEM

It is therefore essential to use the most correct system in relation to the installation needs. The most important parameters to take into consideration when choosing the correct adiabatic system are:

- Forecasted working hours per year;
- Obtainable relative humidity gap (efficiency);
- Obtainable saturation; maximum difference of dry bulb temperature between ambient air temperature and suction air temperature after the adiabatic cooling.

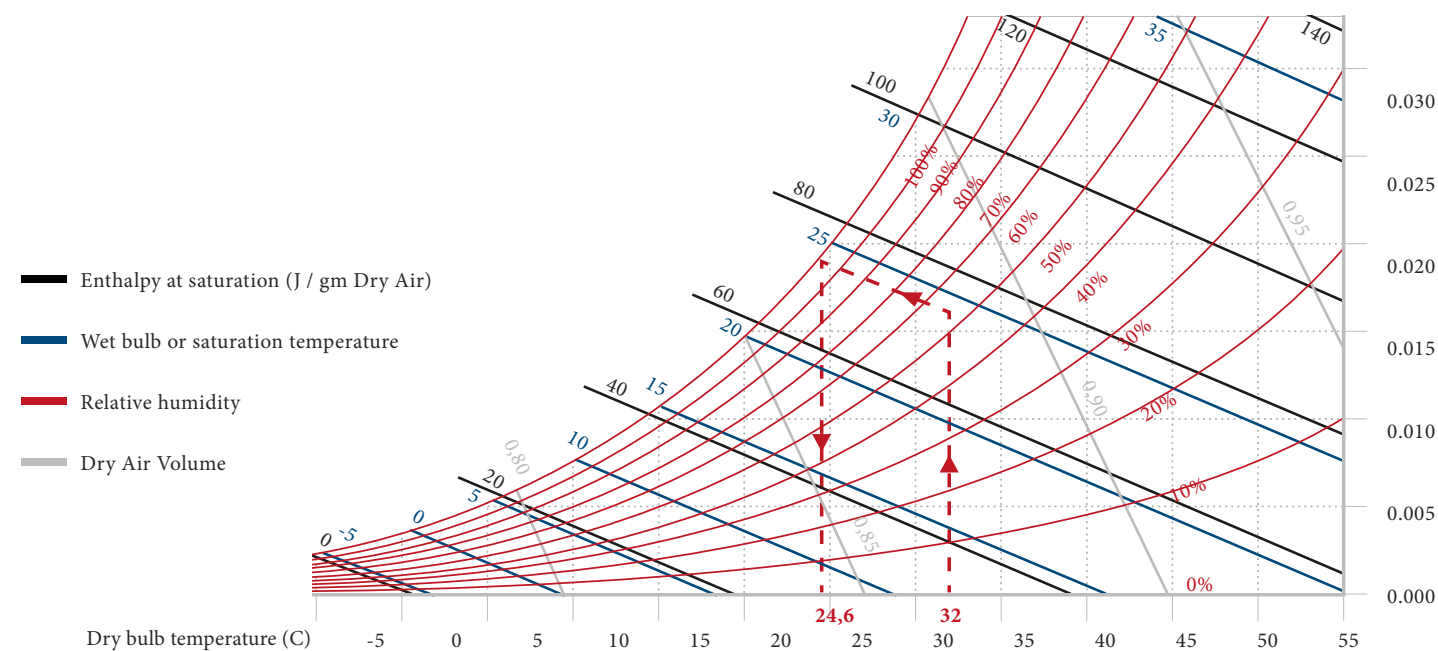

## OPERATING MODES OF THE ADIABATIC SYSTEM

- **Water Saving:** increased specific capacity when using H<sub>2</sub>O - (H<sub>2</sub>O when engine at maximum).
- **Energy Saving:** energy saving to help the fan (H<sub>2</sub>O immediately).

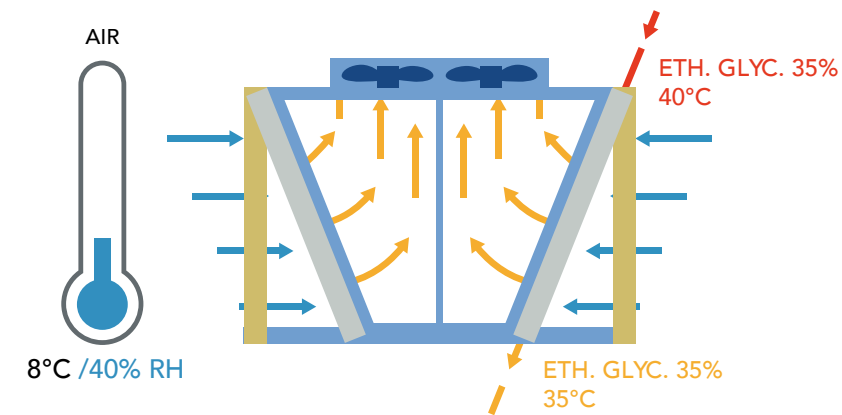

## DRY CONDITION

with low ambient temperature, below the switch-point temperature, with fans at minimum.

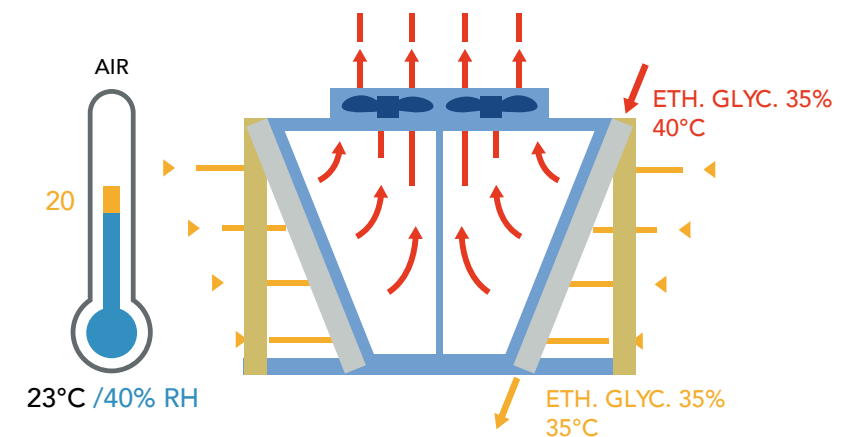

## DRY CONDITION

with high ambient temperature, below the switch-point temperature, with fans at maximum.

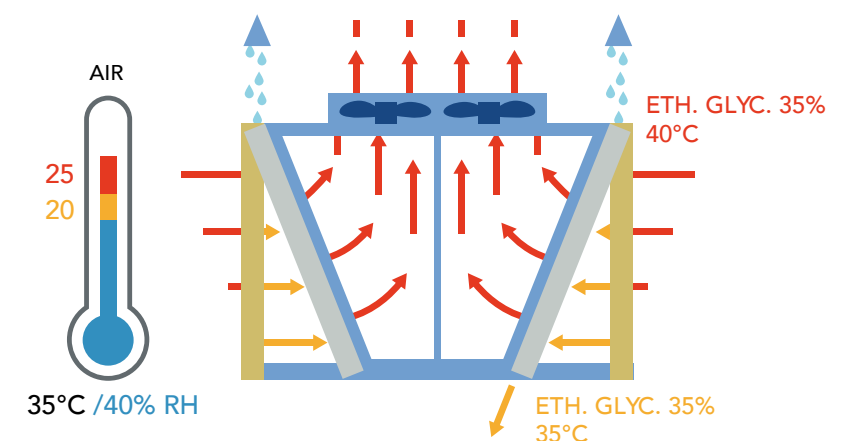

## WET CONDITION

with ambient temperature above the switch-point temperature. Fans at maximum to save water or fans in regulation to save energy.



# Operation and strengths of V-Tower

## NO WATER TREATMENT NEEDED

The water used for the adiabatic system equipped with evaporative panel does not require specific treatments.

## REDUCED WATER AND ENERGY CONSUMPTION

The system works using the minimum amount of water required for the adiabatic cooling, thanks to the high efficiency of the panels, to the water distribution and flow regulation systems. Energy consumption is optimized through the use of low consumption electronically controlled fan motors in combination with the use of the adiabatic system.

## UNLIMITED HOURS PER YEAR

The used panels have no limitation in operation hours.

## LOW TOTAL COST OF OWNERSHIP

The easiness in installation of the modular EPS system, the minimized operating costs, the reduced maintenance and the cost-free panel disposal mean that the cost of the unit's life cycle is limited.

## NO TREATMENT OF THE HEAT EXCHANGER

No treatment of the heat exchanger is necessary because the EPS system does not generate aerosols in the air.

## HEAVY DUTY DESIGN

The adiabatic EPS system has a strong structure and uses materials suitable to last even the most severe environmental conditions.

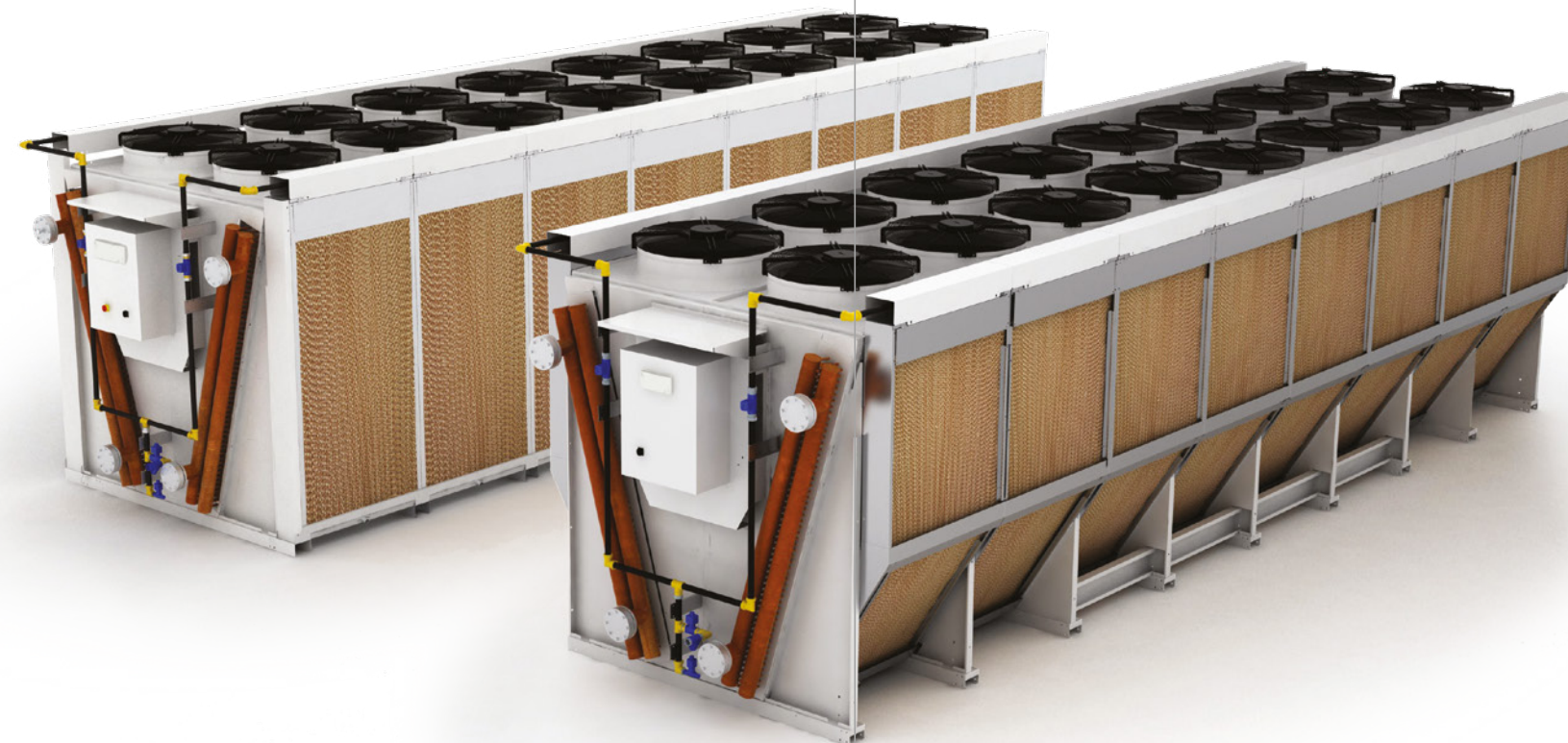

## Benefits

- Easy installation and maintenance
- Energy efficient
- Bespoke solutions
- High corrosion materials resistance
- Minimum capacity/footprint ratio
- Process temperature control
- Two-year product guarantee



## Applications HVAC/R, Energy and process cooling

- Power generation
- Food process cooling industry
- Data centre cooling
- Air conditioning
- Industrial process cooling
- Tooling machines
- Metal processing
- Pharmaceutical
- Plastic
- Textiles

# Technical features

## HIGHLY FUNCTIONAL EVAPORATIVE PANELS

- No water treatment needed
- High quality materials
- Easily removable panels for maintenance and storage, available in two solutions: vertical (JUMBO and SUPER JUMBO) for a better water distribution and sloping (SUPER JUMBO) for the systems where it is necessary to save space, allowing better air recovery as serial large installations.
- No aerosol
- Legionella free
- Dry cooled coil
- No deposits or corrosion
- Reduced disposal costs

## NO WASTE THANKS TO CONTROL

- Reduced water consumption
- EC fans controllers
- Low energy consumption thanks to EC fans
- Phase cut speed controller
- Inverter
- Low water consumption thanks to high level setting of dry/wet control board and regulating devices
- Wired ready to use

## EPS SYSTEM COMPLIANT TO HYGIENE DIRECTIVES

- Hygienic operation
- Plume-free
- No accumulation and stagnation of water
- Automatic draining

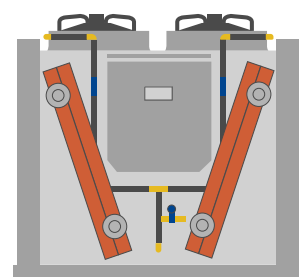

### JUMBO V-TOWER

**Capacity Range** Up to 1400 kW  
Up to 16 fans

**Sizes** 10m

**Weight** 5.000 kg

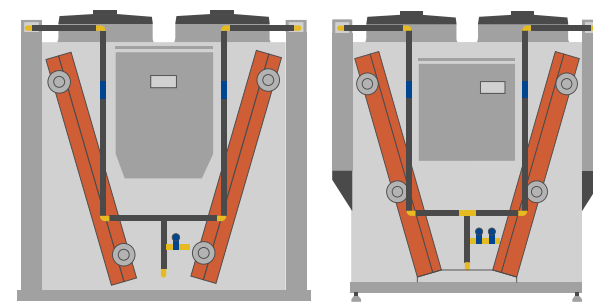

### SUPER JUMBO V-TOWER

**Capacity Range** Up to 2000 kW  
Up to 20 fans

**Sizes** 12m

**Weight** 6300 kg

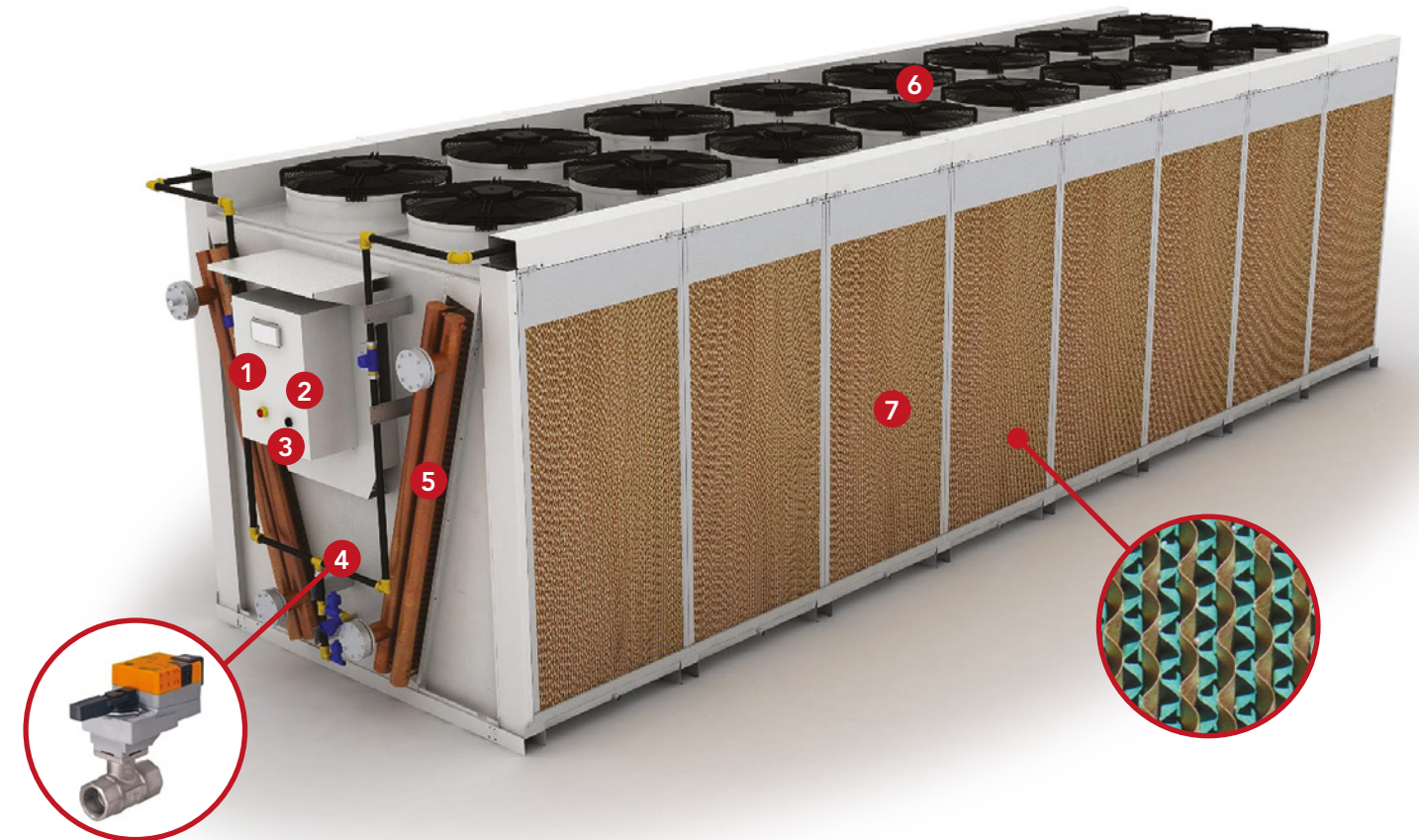

#### 1 ELECTRICAL PANEL

Electrical panel for EC fans with paint coated metal casing, controller mounted inside the box, protected by automatic switches (Circuit breakers) connected to groups of fans, fan regulation control (modbus RS485).

#### 2 SPECIFIC CONTROL BOARD FOR EPS SYSTEM

Controls the water opening and closing valves to optimize their consumption.

#### 3 PIPING NETWORK CONNECTION

HD polyethylene pipe, brass fittings, manual balancing valves, charging solenoid valve, discharge solenoid valve (pre-assembled). Fixing brackets. Stainless steel screws.

#### 4 MOTORIZED MODULATING VALVES

Balanced flow valves with electronic signal control for optimal regulation of the flow rate of each EPS system ramp.

#### 5 WATER DISTRIBUTION PIPING FOR EPS MODULES

HD polyethylene pipe, brass fittings, stainless steel hoses, RAL7035 painted FeZn pipe fixing brackets (pre-assembled). RAL7035 painted FeZn tube protection metal sheets. Stainless steel screws.

#### 6 910 EC FANS

Up to 20 fans  
Fan regulation with Electrical Panel with EC manager control.

#### 7 EPS MODULE KIT

Removable stainless steel modular frame, treated cellulose evaporative panels, water distribution cross with full cone nozzles, modular discharging driptray with piping, resistant to low and high temperatures, resistant to ultraviolet rays and aggressive substances with pre-assembled EPDM lamellar gaskets. Upper covers openable for nozzle cleaning. Nozzles easily disassemblable.



## Comparison

	V-TOWER	COOLING TOWER	DRY COOLER
MOIST AIR SATURATION	90%	100%	/
STANDARD AIR TEMPERATURE REDUCTION	8K	10K	/
WATER CONSUMPTION	LOW	HIGH	/
WATER TREATMENT	NOT NECESSARY	NECESSARY	/
DIRECT ENERGY CONSUMPTION	LOW	LOW	HIGH
ENVIROMENTAL INFLUENCE	LOW	HIGH	LOW
FUNCTIONING HOUR	CONTINUOUS	CONTINUOUS	CONTINUOUS
MAINTENANCE COSTS	LOW	HIGH	/
FOOTPRINT	LOW	MEDIUM	HIGH
HIGH AMBIENT TEMPERATURE	ADAPT	ADAPT	NOT ADAPT

## Industrial vertical V-Tower vs sloping V-Tower

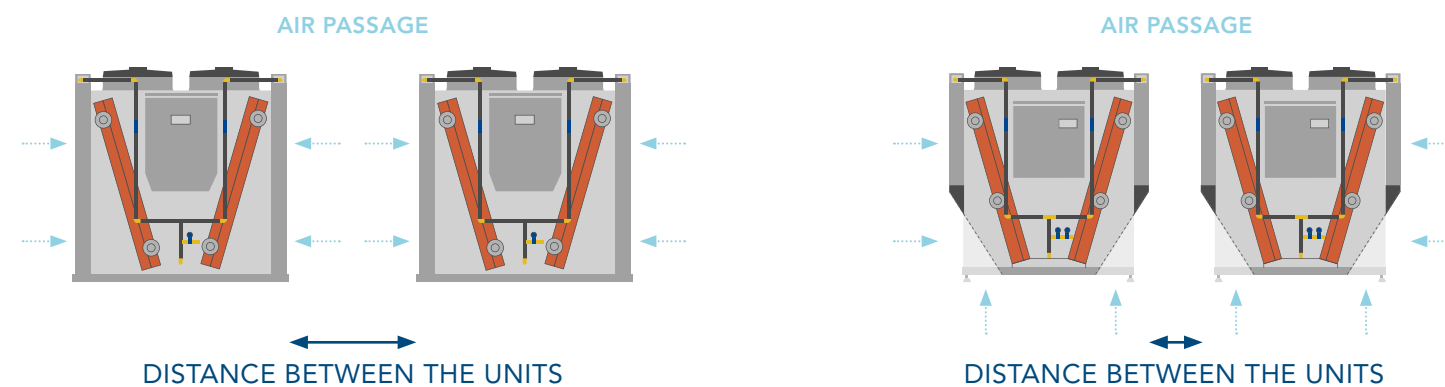

The sloping V-Tower solution saves space when there are more than one unit next to one another without reducing the operating efficiency.

## Construction features

### STANDARD FRAMES

The standard frames have a high structural rigidity in galvanized metal sheets with a high thickness of zinc to guarantee resistance and durability in the most severe environmental conditions. All the visible galvanized metal sheets are also painted with RAL7035 epoxy-polyester powders after the mechanical operations to guarantee the maximum protection possible against corrosion.

### MAXIMUM SECURITY

In addition, to ensure maximum safety in handling and installation operations for the entire life of the product, the lifting and fixing supports are made of hot galvanized structural steel as well as being painted with epoxy-polyester powder, and the internal reinforcement brackets are in stainless steel as well as the all fixing elements (screws, nuts and rivets).

### HEAT EXCHANGER

The finned pack heat exchangers use aluminium alloy plates with deep-drawn holes to avoid damage to copper pipes due to thermal expansion. The high magnesium content alloy gives structural resistance and high resistance to atmospheric agents, guaranteeing the maximum heat exchanger life.

### MATERIALS AND SPECIAL TREATMENTS

Special materials and treatments can be supplied on request both for the frames and for the exchangers with different combinations for the maximum protection possible in particularly aggressive environments.

## Intelligent Control

Control operation becomes fundamental and strategic for an efficient functioning, smart and able to automatically adjust itself to reduce consumption costs. Furthermore, the operating capacity of the single units is optimized, the installation is easy and can be adapted to different types of spaces, the parameters can be comfortably entered to guarantee maximum operating efficiency.

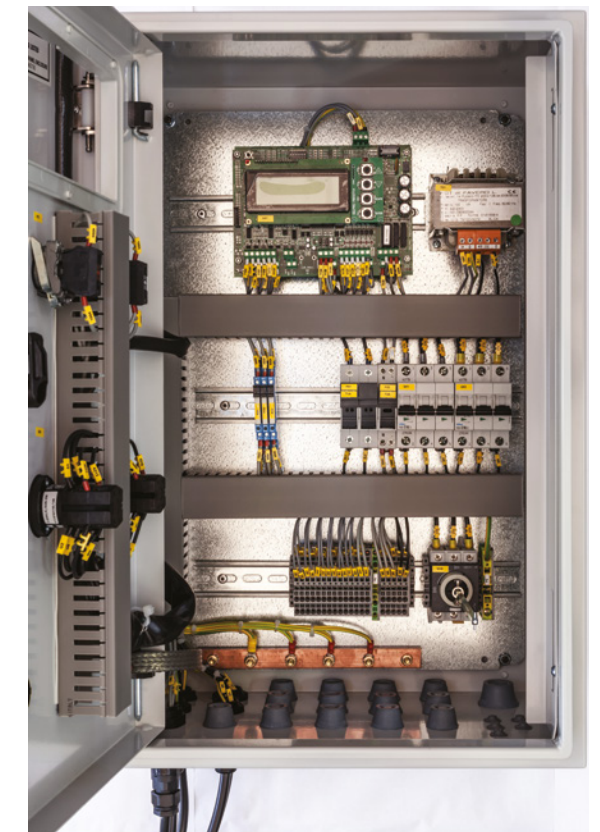

## Optional

### FANMOTORS WITH AXITOP

On request the fan motors can be equipped with diffusers that allow the reduction of the sound level or the increase of efficiency and performance and the increase of the air throw.

### FAST SUITABLE DRAINING HEAT EXCHANGERS

FAST SELF-EMPTYING DRAINABLE SYSTEM ThermoKey has designed a proper self-emptying drainable system during winter time to avoid freezing risk of the finned pack.

### HEAT EXCHANGERS WITH SURFACE TREATMENTS

Fin painting for aggressive environments (e.g. to avoid oxidation).

### STAINLESS STEEL TUBES, FINS AND COIL CASING

ThermoKey can also produce heat exchangers completely in 304 or 316L stainless steel for special applications (particularly aggressive environments) or fluids.

### EC E AC FANMOTORS WITH DEDICATED CONTROL

- R - phase cut speed controller
- SINGLE-PHASE R – phase cut speed controller
- G – step fan speed controller
- Z – inverter speed controller with sinusoidal filters installed
- P – special cut phase fan speed controller (on demand)

### SHOCK ABSORBERS

Shock absorbers can considerably reduce the vibratory disturbance, as well as the noise, since they are installed between the source of vibration and the mechanical anchoring. It is possible to select this standardized accessory or require special dampers for high-seismicity environments.

### ELECTRICAL PANELS FOR REMOTE CONTROL AND READING

The control panels of EC fan motors and EPS system are available on request. The on-board electronics are prepared for modbus signal distribution (RS485).

## Hygienic certification

To guarantee the highest quality and safety of its products, ThermoKey has had its EPS system (Adiabatic Evaporative Panel System) certified by an independent institution.

The hygienic certificate refers to VDI 2047-2 which takes into consideration the requirements set by the law and by industry standards in the main countries of use of the specific product.

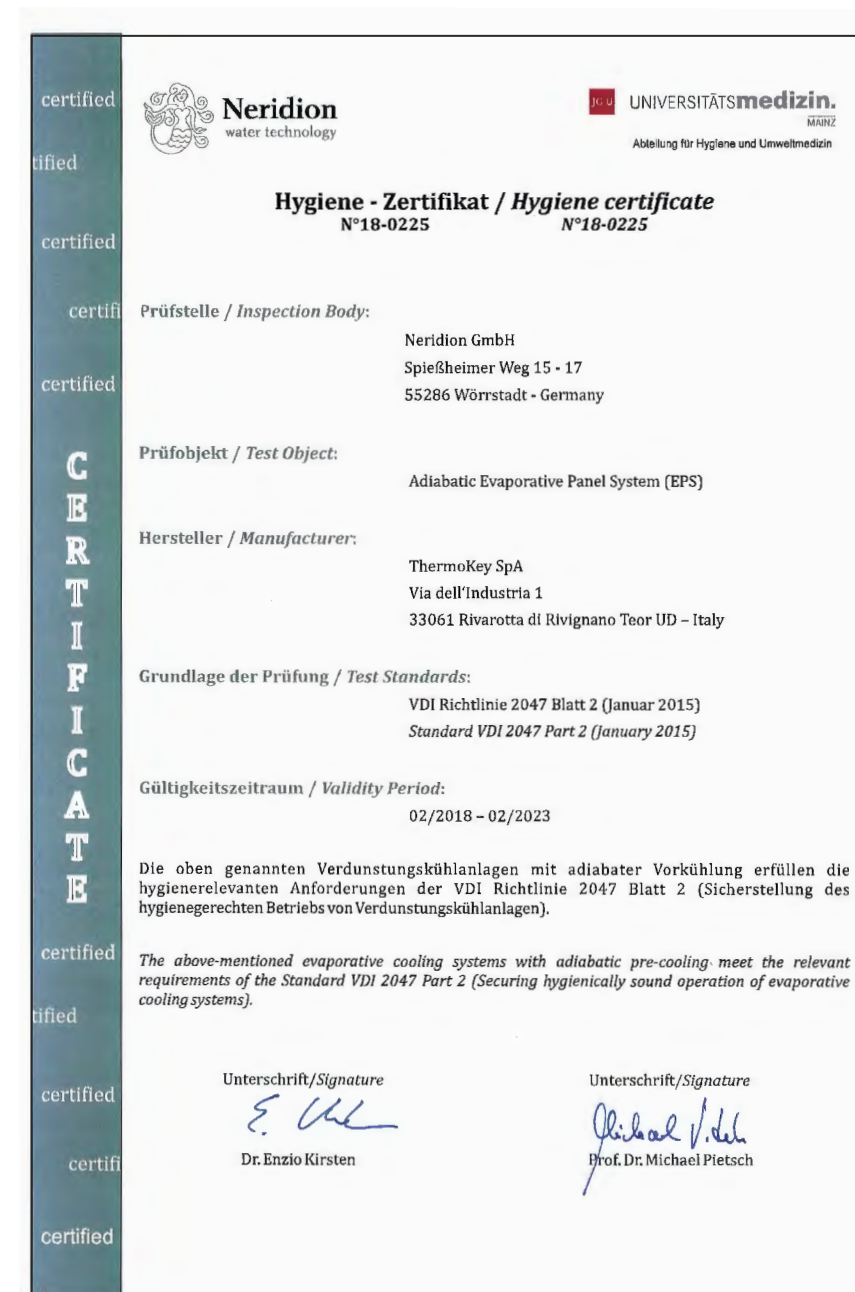



Direction  
Acrobatik  
—  
VT1019EN





# ThermoKey®

Heat Exchange Solutions

**ThermoKey Spa**  
via dell'Industria, 1 - 33061  
Rivarotta di Rivignano Teor (UD) - Italy

T. +39 0432 772300  
F. +39 0432 779734  
info@thermokey.com  
www.thermokey.com

