

---

# INSTALLATION, OPERATION & SERVICE MANUAL

## HORIZONTAL MINI AHU HAHU-EC

---



## INVESTING IN QUALITY, RELIABILITY & PERFORMANCE

### ISO 9001 QUALITY



Management Service

Every product is manufactured to meet the stringent requirements of the internationally recognized ISO 9001 standard for quality assurance in design, development and production.

### World Leading Design and Technology

Equipped with the latest air-conditioning test rooms and manufacturing technology, we produce over 50,000 fan coil units each year, all conforming to the highest international standards of quality and safety.

### CE SAFETY STANDARDS



Product Service

All products conform to the Certificate Europe directives (Machinery Safety, Electromagnetic Compatibility and Low Voltage), as required throughout the European Community, to guarantee correct safety standards.

### The Highest Standards of Manufacturing

In order to guarantee the very highest standards and performance, we manage every stage in the manufacturing of our products. Throughout the production process, we maintain strict control, starting with our extensive resources in research and development through to the design and manufacture of almost every individual component, from moulded plastics to the assembly of units and controllers.

### WEEE MARK



All products conform to the “WEEE” directive to guarantee correct standards of environmental solutions.

### Quality Controlled from Start to Finish

Our highly trained staff and strict quality control methods enable us to produce products with an exceptional reputation for reliability and efficiency, maintained over many years. As well as CE certification and ISO 9001, several products ranges have UL / ETL safety approval in the USA and Canada, Eurovent performance and sound certification, and ROHS compliance for Europe, giving you the confidence to know our company is the right choice when selecting fan coil units.

ALWAYS MAKE SURE THIS MANUAL REMAINS WITH THE UNIT. READ THIS MANUAL BEFORE PERFORMING ANY OPERATION ON THE UNIT.

## TABLE OF CONTENTS

<b>A. TECHNICAL DATA.....</b>	<b>4</b>
A.1. GENERAL DESCRIPTION .....	4
A.2. GENERAL SPECIFICATIONS .....	6
A.3. COIL DATA .....	10
A.4. SOUND DATA .....	11
A.5. DIMENSIONAL DRAWINGS.....	16
<b>B. INSTALLATION .....</b>	<b>18</b>
B.1. SAFETY PRECAUTIONS .....	18
B.2. LOCATION .....	19
B.3. INSTALLATION PROCEDURES .....	20
B.4. INSULATION .....	21
B.5. SERVICE CONNECTION.....	21
B.6. UNIT OPERATION .....	22
<b>C. MAINTENANCE.....</b>	<b>22</b>
C.1. GENERAL MAINTENANCE .....	22
C.2. REGULAR MAINTENANCE .....	22
C.3. FILTER CLEANING .....	22
C.4. FAN MOTOR REPLACEMENT .....	22
<b>D. CONTROL SPECIFICATIONS: INTELLIGENT CONTROL (I TYPE) .....</b>	<b>23</b>
D.1. I/O PORT DEFINITIONS FOR I TYPE .....	23
D.2. WIRING DIAGRAMS FOR I TYPE.....	24
D.3. CONTROL LOGICS FOR I CONTROL .....	26
<i>D.3.1. Control Logics for I Control For EC-S8 (300029=2).....</i>	<i>26</i>
D.4. OPEN MODBUS PROTOCOL .....	33
<i>D.4.1. Open Modbus Protocol For EC-S8.....</i>	<i>33</i>
D.5. MODBUS NETWORK SETUP FOR FCU GROUP.....	37
D.6. LED DISPLAY AND ERROR DESCRIPTION: I-TYPE (OPTIONAL).....	39
<b>E. CONTROL SPECIFICATIONS: FLEXIBLE FUNCTION (W TYPE) .....</b>	<b>40</b>
E.1. I/O PORT DEFINITIONS FOR W TYPE .....	40
E.2. WIRING DIAGRAMS FOR W TYPE.....	41
E.3. CONTROL LOGIC SPECIFICATIONS.....	43
<i>E.3.1. Control Logic Specifications for W4/W5.....</i>	<i>43</i>
E.4. OPEN MODBUS PROTOCOL.....	43
<i>E.4.1. Open Modbus Protocol (For EC-W4/W5 PCB).....</i>	<i>43</i>
<b>F. USER INTERFACE .....</b>	<b>44</b>
F.1. REMOTE HANDSET FOR I-CONTROL .....	44
F.2. WIRED WALL PAD CONTROLLER FOR I-CONTROL.....	45
<i>F.2.1. LED display.....</i>	<i>45</i>
<i>F.2.2. Operation guide .....</i>	<i>46</i>
<i>F.2.3. Error Code List.....</i>	<i>49</i>
<i>F.2.4. Dimensions and installation.....</i>	<i>50</i>
<b>G. SENSOR RESISTANCE R-T CONVERSION TABLE.....</b>	<b>51</b>
<b>H. TROUBLESHOOTING.....</b>	<b>52</b>

## MODEL CODE NOMENCLATURE

<u>1</u>	2	<u>3</u>	4	5	6	7
<u>HAHU</u>	-4R	<u>-200</u>	<u>-V</u>	<u>I</u>	<u>-EC</u>	<u>-RS</u>

Notation		Description
1	<b>HAHU</b>	Horizontal Air Handling Unit
2	<b>4R</b>	4R: 2-pipe 4 rows 6R: 2-pipe 6 rows 4R+2: 4-pipe with 4rows cooling and 2 rows heating
3	<b>200</b>	<b>Unit Size</b> (See General Specification Section A for cooling and heating capacities.)
4	<b>V</b>	V – 2 pipe system P – 4 pipe system
5	<b>I</b>	<b>Control type:</b> I – Intelligent Control W – Flexible function Control
6	<b>EC</b>	EC Motor
7	<b>RS</b>	<b>Connection type:</b> RS – Right LS – Left

## A. Technical Data

### A.1. General Description

HAHU unit is an ideal air handling terminal unit for suspended ceiling installation and suitable for ducted air distribution. It is constructed of sandwich panels to achieve low noise level during operation. HAHU air handling unit is shipped completely assembled and motor wiring is introduced into the control box to reduce on-site installation time and manpower. Every unit is thoroughly inspected and tested to clear up potential problems during startup. The unit contains side panels that provide easy access to fans, motors and filters.

#### FRAMEWORK

A frameless structure is used. The panel is integrated folding steel structure and tested to ensure that there is no air leakage.

#### CASING

Casing is double skinned and basically consists of two panels with internal insulation. Each panel is 1" thick. The inner and outer panels are made of plane galvanized steel and pre-coated galvanized steel. The insulation consists of a high-pressure PU foam sandwiched in between to reinforce the panel.

#### FILTER

Filter is washable, double-layer acrylic nylon with aluminum frame. G4 (Merv 8) or F8 (Merv 14) filter is optional.

#### COIL

Coils are standard Cu/Al 3/8" OD provided with manual Air-Vent valves. The manifolds are made of steel with threaded connections. The aluminum fins are pre-coated for protection by hydrophilic blue fin process. Coils are tested at 35 bar and recommended maximum operation at 20 bar.

#### DRAIN PAN

Drain pan is made of single wall painting steel with 3/16" insulation on outer wall. The drain pan extends the full length and width of the coil and is sloped for positive drainage and includes 3/4" male pipe threaded galvanized drain connector.

#### FAN SECTION

Fans are mainly constructed of housing, impeller, mounting feet, and DC motor. The housing is made of hot-dip galvanized steel. The side panel includes inlet cones whose inlet conditions are designed for optimum aerodynamics. The scroll is fixed on the side panel by spot welding. The wheel is made of hot-dip galvanized steel. The forward curved blades feature an advanced aerodynamic design for maximum efficiency and minimum noise level. The impeller is fixed on the center plate and on the end ring with riveting compression. The impeller is designed for maximum strength and can withstand continuous operation with maximum power. All impellers and motor are fully balanced according to ANSI/AMCA-204 standard. The mounting feet are made of galvanized steel sheet with unique technical to ensure adequate strength. HAHU fans are equipped with YZWWSL external rotor BLDC motor. The motor consists of motor body and BLDC driver, controlled by 0~10VDC or Modbus RS485. This new designed motor significantly reduces motor torque fluctuation, vibration and noise resulting in high efficiency, reliability and long-life operation.

#### CONTROL SYSTEMS

##### 1. Intelligent control (I type)

Intelligent control board is controlled via Infra-red handset and/or Intelligent wired wall pad, is field programmable and easy to be configured through the wired wall pad or open Modbus protocol with VV and VAV control logics, provides variable speed indoor fan control, integrates with Intelligent modulating valves to allow Auto Dynamic Balancing and Intelligent Constant Delta T management systems. It controls 2-pipe, 2-pipe with electric heater, 2-pipe with 6-way valve and 4-pipe systems.

##### 2. Flexible control (W type)

This control options features flexible functionality for external thermostat applications, allowing the independent control of drain pumps (if equipped), offering zone control operations, and limited diagnostics. In products where louvers are required, this control allows the stepping motors to open the louver at maximum position or close them when power of the unit is OFF.

**ACCESSORIES**

Optional accessories can be selected: G4 (Merv 8 ) or F8 (Merv 14) filter module, Mixing and recirculating chamber, 0~10V Modulating 2-way valve kit, On/Off valve kit, Electrical heating module, thermostat, AQI control PCB-S5, Complete function PCB-S6, Wired wall pad, Differential pressure transducer.

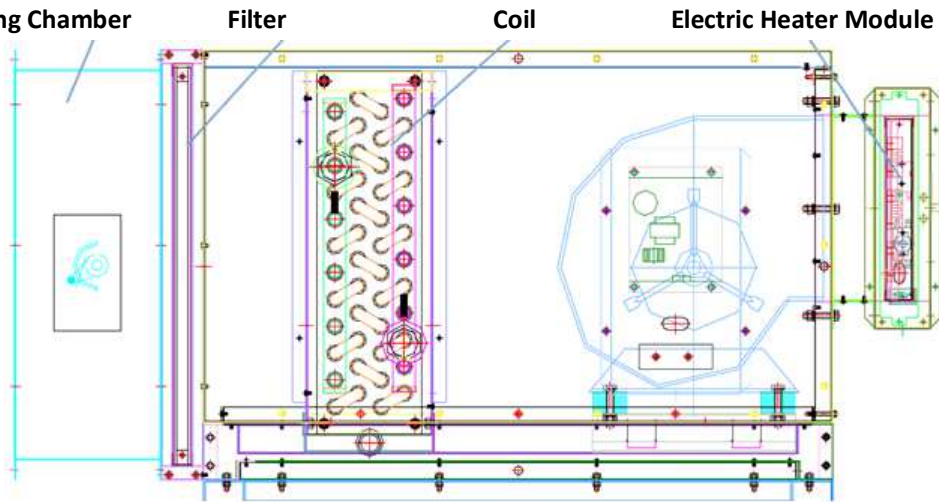
**Mixing &****Recirculating Chamber**

## A.2. General Specifications

**Product range:** HAHU-4R-V-EC 4-row coil 2-pipe with EC motor(s)

HAHU-4R-[Size]-V-EC				200	300	400	600	800	
<b>Unit configuration</b>	Configuration			2 pipes					
	Number of Fan Blowers			1			2		
	Power supply (V/Ph/Hz)			220~240/1/50 or 60					
<b>Performance Data</b>	<b>Air</b>	Air flow	H	m3/hr	2329	3238	4166	6475	8332
			M		1980	2752	3541	5504	7082
			L		1398	1943	2500	3885	4999
	External Static Pressure	H	Pa	120					
		M		120					
		L		120					
	<b>Cooling</b>	Cooling capacity	H	kW	16.3	21.9	28.5	43.1	54.3
			M		14.4	19.4	25.4	38.2	48.3
			L		11.0	14.8	19.1	29.2	36.4
		Sensible cooling capacity	H		11.4	15.5	20.1	30.5	38.5
			M		10.0	13.6	17.6	26.7	33.9
			L		7.6	10.3	13.2	20.1	25.3
<b>Heating</b>	Heating capacity	H	kW	19.5	26.3	34.3	51.8	65.1	
		M		17.3	23.3	30.5	45.8	57.9	
		L		13.2	17.8	23.0	35.0	43.7	
	Max. EH capacity	kW		4.5	6	7.5	9	9	
<b>Sound</b>	Sound Pressure		dB(A)	62	66	72	71	75	
	Sound Power			71	75	81	80	84	
<b>Electrical</b>	Power Input		W	375	501	504	1001	1005	
	Current		A	1.63	2.17	2.17	4.34	4.34	
<b>Hydraulic</b>	Cooling Water Flow Rate	H	L/h	2787	3749	4892	7392	9301	
		M		2467	3321	4351	6548	8272	
		L		1892	2535	3280	4999	6236	
	Cooling Pressure Drop	H	kPa	24	15.1	26.6	61.1	47.3	
		M		19.3	12.1	21.5	49.1	38.3	
		L		12	7.5	13	30.2	23	
	Heating Water Flow Rate		L/h	Same As "Cooling Water Flow Rate"					
	Heating Pressure Drop	H	kPa	21.6	13.6	23.9	55.0	42.6	
M		17.4		10.9	19.4	44.2	34.5		
L		10.8		6.7	11.7	27.2	20.7		
Water content		L	7.38	9.12	10.9	12.6	15.2		
<b>Construction and Packing Data</b>	Water Connections	In	inch	1 1/4"					
		Out							
	Condensate Drainage Connection		inch	1"					
	Dimensions	L	mm	1280	1480	1680	1880	2180	
		W		1120					
H		640							
Net Weight		kg	150	175	186	223	255		

Conditions:

a. Cooling mode:

- Return air temperature: 27C DB/ 19C WB.
- Inlet/ outlet water temperature: 7C/ 12C.

b. Heating mode:

- Return air temperature: 20C.
- Inlet water temperature: 50C.
- Same water flow as cooling mode.

Product range: HAHU-6R-V-EC 6-row coil 2-pipe with EC motor(s)

HAHU-6R-[Size]-V-EC				200	300	400	600	800	
Unit configuration	Configuration			2 pipes					
	Number of Fan Blowers			1			2		
	Power supply (V/Ph/Hz)			220~240/1/50 or 60					
Performance Data	Air	Air flow	H	m <sup>3</sup> /hr	2329	3238	4166	6475	8332
			M		1980	2752	3541	5504	7082
			L		1398	1943	2500	3885	4999
		External Static Pressure	H	Pa	100				
			M		100				
			L		100				
	Cooling	Total Cooling capacity	H	kW	17.8	25.2	32.7	46.4	60.7
			M		15.8	22.3	29.1	41.1	54.0
			L		12.1	17.0	22.0	31.4	40.7
		Sensible cooling capacity	H		12.2	17.3	22.3	32.5	42.3
			M		10.8	15.2	19.6	28.5	37.2
			L		8.1	11.4	14.6	21.5	27.7
	Heating	Heating capacity	H	kW	21.4	30.2	39.3	55.7	72.9
			M		18.9	26.8	35.0	49.3	64.8
			L		14.5	20.5	26.4	37.6	48.9
		Max. EH capacity			kW	4.5	6	7.5	9
	Sound	Sound Pressure		dB(A)	62	66	72	71	75
		Sound Power			71	75	81	80	84
	Electrical	Power Input		W	375	501	505	1001	1005
		Current		A	1.63	2.17	2.17	4.34	4.34
	Hydraulic	Cooling Water Flow Rate	H	L/h	3052	4320	5613	7949	10406
			M		2702	3826	4992	7041	9256
			L		2072	2921	3764	5375	6978
		Cooling Pressure Drop	H	kPa	14.0	28.9	51.0	15.5	28.4
M			11.3		23.2	41.3	12.4	23.0	
L			7.0		14.3	24.8	7.7	13.8	
Heating Water Flow Rate		L/h	Same As "Cooling Water Flow Rate"						
Heating Pressure Drop		H	kPa	12.6	26.0	45.9	13.9	25.5	
		M		10.1	20.9	37.2	11.2	20.7	
		L		6.3	12.9	22.4	6.9	12.4	
Water content		L	11.1	13.7	16.3	18.9	22.8		
Construction and Packing Data	Water Connections	In	Inch	1 1/4"					
		Out							
	Condensate Drainage Connection		inch	1"					
	Dimensions	L	mm	1280	1480	1680	1880	2180	
		W		1120					
H		640							
Net Weight		kg	160	187	202	241	273		

Conditions:

a. Cooling mode:

- Return air temperature: 27C DB/ 19C WB.
- Inlet/ outlet water temperature: 7C/ 12C.

b. Heating mode:

- Return air temperature: 20C.
- Inlet water temperature: 50C.
- Same water flow as cooling mode.



**Product range:** HAHU-4R+1-P-EC 4-row coil for cooling and 1-row coil for heating 4-pipe with EC motor(s)

HAHU-4R+1-[Size]-P-EC				200	300	400	600	800	
Unit configuration		Configuration		4 pipes					
		Number of Fan Blowers		1			2		
		Power supply (V/Ph/Hz)		220~240/1/50 or 60					
Performance Data	Air	Air flow	H	m <sup>3</sup> /hr	2422	3304	4228	6608	8457
			M		2058	2808	3594	5617	7188
			L		1453	1982	2537	3965	5074
		External Static Pressure	H	Pa	100				
			M		100				
			L		100				
	Cooling	Total Cooling capacity	H	kW	16.8	22.2	29	43.7	55.1
			M		14.8	19.7	25.6	38.8	48.7
			L		11.4	15	19.4	29.5	36.8
		Sensible cooling capacity	H		11.8	15.8	20.4	30.9	39.1
			M		10.3	13.9	17.8	27.2	34.2
			L		7.8	10.4	13.3	20.4	25.6
	Heating	Heating capacity	H	kW	13.8	18.2	23	33.5	42
			M		12.3	16.1	20.4	29.7	37.3
			L		9.4	12.3	15.4	22.7	28.2
	Sound	Sound Pressure		dB(A)	62	66	72	71	75
		Sound Power			71	75	81	80	84
	Electrical	Power Input		W	375	501	505	1001	1005
		Current		A	1.63	2.17	2.17	4.34	4.34
	Hydraulic	Cooling Water Flow Rate	H	L/h	2879	3802	4964	7498	9437
M			2542		3374	4389	6654	8344	
L			1954		2566	3322	5060	6316	
Cooling Pressure Drop		H	kPa	25.5	15.5	27.3	62.7	48.6	
		M		20.4	12.5	21.9	50.6	38.9	
		L		12.7	7.6	13.3	30.9	23.6	
Heating Water Flow Rate		H	L/h	1186	1555	1970	2875	3599	
		M		1053	1378	1751	2546	3198	
		L		804	1053	1322	1946	2415	
Heating Pressure Drop		H	kPa	39.6	10.6	18.2	40.2	22	
		M		32	8.5	14.7	32.3	17.8	
		L		19.7	5.2	8.9	19.9	10.7	
Cooling Water Content		L	7.38	9.12	10.85	12.59	15.19		
Heating Water Content			1.845	2.28	2.715	3.15	3.8		
Construction and Packing Data	Cooling Water Connections	In	inch	1 1/4"					
		Out							
	Heating Water Connections	In		1"					
		Out							
	Condensate Drainage Connection		inch	1"					
	Dimensions	L	mm	1280	1480	1680	1880	2180	
W		1120							
H		640							
Net Weight		kg	155	177	195	232	264		

Conditions:

a. Cooling mode:

- Return air temperature: 27C DB/ 19C WB.

- Inlet/ outlet water temperature: 7C/ 12C.

b. Heating mode:

- Air temperature: 20C.

- Water inlet/ outlet temperature: 65/55C.

Product range: HAHU-4R+2-P-EC 4-row coil for cooling and 2-row coil for heating 4-pipe with EC motor(s)

HAHU-4R+2-[Size]-P-EC				200	300	400	600	800	
Unit configuration	Configuration			4 pipes					
	Number of Fan Blowers			1			2		
	Power supply (V/Ph/Hz)			220~240/1/50 or 60					
Performance Data	Air	Air flow	H	m3/hr	2537	3387	4307	6774	8613
			M		2156	2879	3661	5758	7321
			L		1522	2032	2584	4064	5168
		External Static Pressure	H	Pa	100				
			M		100				
			L		100				
	Cooling	Total Cooling capacity	H	kW	17.4	22.7	29.4	44.7	55.9
			M		15.4	20.0	26.0	39.4	49.5
			L		11.8	15.3	19.9	30.2	37.8
		Sensible cooling capacity	H		12.2	16.1	20.7	31.6	39.7
			M		10.7	14.1	18.1	27.7	34.8
			L		8.1	10.7	13.7	20.9	26.3
	Heating	Heating capacity	H	kW	21.8	28.8	36.2	54.0	67.6
			M		19.2	25.4	32.0	47.6	59.7
			L		14.7	19.3	24.2	36.2	45.3
	Sound	Sound Pressure		dB(A)	62	66	72	71	75
		Sound Power			71	75	81	80	84
	Electrical	Power Input		W	375	501	505	1001	1005
Current		A	1.63	2.17	2.17	4.34	4.34		
Hydraulic	Cooling Water Flow Rate	H	L/h	2980	3883	5036	7656	9574	
		M		2636	3428	4461	6759	8481	
		L		2016	2628	3405	5182	6474	
	Cooling Pressure Drop	H	kPa	27.1	16.0	28.0	65.1	49.8	
		M		21.7	12.8	22.5	52.0	40.1	
		L		13.4	8.0	13.9	32.2	24.6	
	Heating Water Flow Rate	H	L/h	1872	2469	3102	4629	5793	
		M		1646	2177	2740	4081	5116	
		L		1262	1655	2077	3104	3879	
	Heating Pressure Drop	H	kPa	26.3	15.8	11.9	27.3	15.0	
		M		20.9	12.6	9.5	21.8	12.0	
		L		12.9	7.7	5.8	13.3	7.3	
Cooling Water Content		L	7.38	9.12	10.85	12.59	15.19		
Heating Water Content			3.69	4.56	5.43	6.3	7.6		
Construction and Packing Data	Cooling Water Connections	In	inch	1 1/4"					
		Out							
	Heating Water Connections	In	inch	1"					
		Out							
	Condensate Drainage Connection		inch	1"					
	Dimensions	L	mm	1280	1480	1680	1880	2180	
W		1120							
H		640							
Net Weight		kg	160	180	202	241	273		

Conditions:

a. Cooling mode:

- Return air temperature: 27C DB/ 19C WB.

- Inlet/ outlet water temperature: 7C/ 12C.

b. Heating mode:

- Air temperature: 20C.

- Water inlet/ outlet temperature: 65/55C.

### A.3. Coil Data

#### 2-Pipe Systems 4 rows coil

Model	Fin height (mm)	Fin Length (mm)	Fins per Inch	No. of Rows	Fin width (mm)	No. of Circuits	Tube Ø (mm)
HAHU-4R-200	456	850	10	4	132	4	15.88
HAHU-4R-300		1050				6	
HAHU-4R-400		1250				6	
HAHU-4R-600		1450				6	
HAHU-4R-800		1750				8	

#### 2-Pipe Systems-6 rows coil

Model	Fin height (mm)	Fin Length (mm)	Fins per Inch	No. of Rows	Fin width (mm)	No. of Circuits	Tube Ø (mm)
HAHU-6R-200	456	850	10	6	198	6	15.88
HAHU-6R-300		1050				6	
HAHU-6R-400		1250				6	
HAHU-6R-600		1450				12	
HAHU-6R-800		1750				12	

#### 4-Pipe Systems (1 row Auxiliary Heating Coil)

Model	Fin height (mm)	Fin Length (mm)	Fins per Inch	No. of Rows	Fin width (mm)	No. of Circuits	Tube Ø (mm)
HAHU-200	456	850	10	1	33	1	15.88
HAHU-300		1050				1	
HAHU-400		1250				2	
HAHU-600		1450				2	
HAHU-800		1750				5	

#### 4-Pipe Systems (2 row Auxiliary Heating Coil)

Model	Fin height (mm)	Fin Length (mm)	Fins per Inch	No. of Rows	Fin width (mm)	No. of Circuits	Tube Ø (mm)
HAHU-200	456	850	10	2	66	1	15.88
HAHU-300		1050				2	
HAHU-400		1250				4	
HAHU-600		1450				4	
HAHU-800		1750				6	

## A.4. Sound Data

Model		HAHU-200-EC							
Speed		800 RPM	900 RPM	1000 RPM	1100 RPM	1200 RPM	1300 RPM	1400 RPM	1500 RPM
Sound Power dB(A)		53.6	57.3	64.4	68.7	71.3	70.7	70.5	71.3
Sound Power in 1/3 Octave-bands under ESP:120Pa (dB)	20 Hz	14.4	9.1	13.0	12.5	23.7	15.0	17.2	14.4
	25 Hz	13.0	12.9	12.5	14.4	19.2	15.4	15.0	16.1
	31.5 Hz	14.0	10.8	21.0	23.1	25.3	19.6	20.4	22.9
	40 Hz	17.3	23.7	21.2	24.6	27.8	25.7	27.4	23.9
	50 Hz	26.9	30.7	32.0	31.0	40.2	33.5	37.5	30.2
	63 Hz	29.8	34.2	38.0	41.2	44.7	40.6	42.6	41.6
	80 Hz	33.2	40.0	40.8	43.5	43.0	45.3	45.3	47.1
	100 Hz	31.2	37.0	39.5	42.8	46.4	45.2	45.0	41.4
	125 Hz	31.1	36.1	42.1	42.6	45.4	45.1	46.1	46.5
	160 Hz	39.7	39.7	45.2	47.5	49.9	50.5	50.0	48.8
	200 Hz	40.5	42.4	50.7	53.7	54.9	54.3	56.5	55.3
	250 Hz	39.1	42.7	50.0	54.8	57.0	57.2	56.0	55.5
	315 Hz	44.7	43.4	51.7	57.6	62.2	60.2	58.2	59.8
	400 Hz	41.3	43.6	49.3	55.2	57.1	55.8	55.2	56.6
	500 Hz	43.8	44.8	49.9	56.1	58.2	56.6	57.3	56.9
	630 Hz	48.4	50.3	55.2	60.5	61.4	61.1	60.9	61.5
	800 Hz	46.2	46.4	53.1	57.7	59.7	59.7	59.5	60.5
	1000 Hz	45.9	46.9	54.4	58.1	61.5	61.1	61.0	61.4
	1250 Hz	44.6	46.2	54.2	57.9	62.1	60.5	60.4	61.9
	1600 Hz	42.6	46.2	54.4	57.5	60.0	59.6	59.2	61.2
2000 Hz	42.6	45.7	53.2	57.1	59.9	59.5	59.0	60.2	
2500 Hz	40.9	44.3	53.7	57.6	60.5	60.0	59.5	60.3	
3150 Hz	37.9	41.9	52.1	56.8	60.0	59.2	59.5	59.5	
4000 Hz	35.1	38.3	48.6	53.9	57.5	56.8	56.8	57.2	
5000 Hz	29.2	32.8	43.5	48.5	52.7	51.8	51.5	53.2	
6300 Hz	26.2	31.6	41.9	46.7	51.0	50.5	50.1	50.9	
8000 Hz	21.6	27.6	36.8	42.5	46.7	46.0	45.9	46.4	
10000 Hz	16.4	23.8	30.8	35.9	39.9	39.2	39.4	39.9	
12500 Hz	12.0	19.7	25.8	29.7	34.2	33.3	33.2	34.1	
16000 Hz	16.7	21.7	19.8	22.6	25.9	25.3	24.9	27.3	

Model		HAHU-300-EC							
Speed		800 RPM	900 RPM	1000 RPM	1100 RPM	1200 RPM	1300 RPM	1350 RPM	1400 RPM
Sound Power dB(A)		56.6	59.9	67.7	72.6	75.2	74.2	74.1	74.3
Sound Power in 1/3 Octave-bands under ESP:120Pa (dB)	20 Hz	18.4	15.1	25.9	27.9	19.2	29.0	32.7	32.7
	25 Hz	9.9	16.8	19.6	19.6	22.0	24.1	23.4	23.4
	31.5 Hz	19.0	17.7	21.8	27.5	24.8	27.9	30.2	30.2
	40 Hz	21.0	23.3	27.2	28.6	31.4	29.7	32.8	32.8
	50 Hz	26.4	33.8	31.1	32.8	32.1	35.4	41.5	41.5
	63 Hz	30.9	32.6	37.7	40.5	41.0	42.1	41.2	41.2
	80 Hz	37.3	39.6	43.9	44.7	47.6	45.2	49.3	49.3
	100 Hz	35.6	41.8	44.0	49.3	52.4	50.9	53.5	53.5
	125 Hz	39.9	42.2	49.8	52.7	54.6	53.4	55.4	55.4
	160 Hz	40.6	44.6	48.6	54.6	57.8	55.6	54.6	54.6
	200 Hz	44.0	45.3	52.5	60.0	59.6	61.1	61.2	61.2
	250 Hz	44.5	49.1	53.5	58.2	59.5	60.3	58.6	58.6
	315 Hz	46.0	50.0	53.9	59.8	61.3	59.8	60.9	60.9
	400 Hz	45.2	48.3	52.8	58.3	59.8	59.8	59.5	59.5
	500 Hz	44.1	47.6	53.3	57.9	59.7	59.3	59.8	59.8
	630 Hz	44.5	48.7	55.7	59.8	62.2	60.9	61.3	61.3
	800 Hz	51.3	50.4	58.6	63.2	66.1	64.0	64.9	64.9
	1000 Hz	45.6	49.3	58.5	62.7	65.8	64.2	64.2	64.2
	1250 Hz	43.7	48.8	58.4	62.5	66.2	64.7	65.0	65.0
	1600Hz	43.9	49.3	57.7	61.9	65.1	64.0	64.0	64.0
2000 Hz	42.4	47.0	56.4	61.0	63.9	62.6	62.8	62.8	
2500 Hz	40.7	45.7	56.3	61.2	63.5	62.6	63.1	63.1	
3150 Hz	39.0	43.9	55.5	59.9	63.9	62.2	62.3	62.3	
4000 Hz	35.7	40.4	53.9	58.7	62.3	60.9	60.8	60.8	
5000 Hz	31.3	36.7	50.2	55.7	59.4	57.7	57.8	57.8	
6300 Hz	25.6	31.4	45.3	51.1	54.7	53.4	53.4	53.4	
8000 Hz	19.9	26.5	40.4	46.9	50.8	49.3	49.1	49.1	
10000 Hz	14.4	20.2	34.6	41.9	46.3	44.2	44.2	44.2	
12500 Hz	10.5	14.0	27.8	35.1	39.9	37.6	37.9	37.9	
16000 Hz	20.2	20.3	22.4	26.9	31.2	29.4	29.3	29.3	

Model		HAHU-400-EC							
Speed		800 RPM	900 RPM	1000 RPM	1100 RPM	1200 RPM	1300 RPM	1350 RPM	1400 RPM
Sound Power dB(A)		62.1	65.4	73.2	78.1	80.7	79.7	79.6	79.8
Sound Power in 1/3 Octave-bands under ESP:120Pa (dB)	20 Hz	23.9	20.6	31.4	33.4	24.7	34.5	38.2	38.2
	25 Hz	15.4	22.3	25.1	25.1	27.5	29.6	28.9	28.9
	31.5 Hz	24.5	23.2	27.3	33.0	30.3	33.4	35.7	35.7
	40 Hz	26.5	28.8	32.7	34.1	36.9	35.2	38.3	38.3
	50 Hz	31.9	39.3	36.6	38.3	37.6	40.9	47.0	47.0
	63 Hz	36.4	38.1	43.2	46.0	46.5	47.6	46.7	46.7
	80 Hz	42.8	45.1	49.4	50.2	53.1	50.7	54.8	54.8
	100 Hz	41.1	47.3	49.5	54.8	57.9	56.4	59.0	59.0
	125 Hz	45.4	47.7	55.3	58.2	60.1	58.9	60.9	60.9
	160 Hz	46.1	50.1	54.1	60.1	63.3	61.1	60.1	60.1
	200 Hz	49.5	50.8	58.0	65.5	65.1	66.6	66.7	66.7
	250 Hz	50.0	54.6	59.0	63.7	65.0	65.8	64.1	64.1
	315 Hz	51.5	55.5	59.4	65.3	66.8	65.3	66.4	66.4
	400 Hz	50.7	53.8	58.3	63.8	65.3	65.3	65.0	65.0
	500 Hz	49.6	53.1	58.8	63.4	65.2	64.8	65.3	65.3
	630 Hz	50.0	54.2	61.2	65.3	67.7	66.4	66.8	66.8
	800 Hz	56.8	55.9	64.1	68.7	71.6	69.5	70.4	70.4
	1000 Hz	51.1	54.8	64.0	68.2	71.3	69.7	69.7	69.7
	1250 Hz	49.2	54.3	63.9	68.0	71.7	70.2	70.5	70.5
	1600Hz	49.4	54.8	63.2	67.4	70.6	69.5	69.5	69.5
2000 Hz	47.9	52.5	61.9	66.5	69.4	68.1	68.3	68.3	
2500 Hz	46.2	51.2	61.8	66.7	69.0	68.1	68.6	68.6	
3150 Hz	44.5	49.4	61.0	65.4	69.4	67.7	67.8	67.8	
4000 Hz	41.2	45.9	59.4	64.2	67.8	66.4	66.3	66.3	
5000 Hz	36.8	42.2	55.7	61.2	64.9	63.2	63.3	63.3	
6300 Hz	31.1	36.9	50.8	56.6	60.2	58.9	58.9	58.9	
8000 Hz	25.4	32.0	45.9	52.4	56.3	54.8	54.6	54.6	
10000 Hz	19.9	25.7	40.1	47.4	51.8	49.7	49.7	49.7	
12500 Hz	16.0	19.5	33.3	40.6	45.4	43.1	43.4	43.4	
16000 Hz	25.7	25.8	27.9	32.4	36.7	34.9	34.8	34.8	

Model		HAHU-600-EC							
Speed		800 RPM	900 RPM	1000 RPM	1100 RPM	1200 RPM	1300 RPM	1350 RPM	1400 RPM
Sound Power dB(A)		60.6	63.9	71.7	76.6	79.2	78.2	78.1	78.3
Sound Power in 1/3 Octave-bands under ESP:120Pa (dB)	20 Hz	22.4	19.1	29.9	31.9	23.2	33.0	36.7	36.7
	25 Hz	13.9	20.8	23.6	23.6	26.0	28.1	27.4	27.4
	31.5 Hz	23.0	21.7	25.8	31.5	28.8	31.9	34.2	34.2
	40 Hz	25.0	27.3	31.2	32.6	35.4	33.7	36.8	36.8
	50 Hz	30.4	37.8	35.1	36.8	36.1	39.4	45.5	45.5
	63 Hz	34.9	36.6	41.7	44.5	45.0	46.1	45.2	45.2
	80 Hz	41.3	43.6	47.9	48.7	51.6	49.2	53.3	53.3
	100 Hz	39.6	45.8	48.0	53.3	56.4	54.9	57.5	57.5
	125 Hz	43.9	46.2	53.8	56.7	58.6	57.4	59.4	59.4
	160 Hz	44.6	48.6	52.6	58.6	61.8	59.6	58.6	58.6
	200 Hz	48.0	49.3	56.5	64.0	63.6	65.1	65.2	65.2
	250 Hz	48.5	53.1	57.5	62.2	63.5	64.3	62.6	62.6
	315 Hz	50.0	54.0	57.9	63.8	65.3	63.8	64.9	64.9
	400 Hz	49.2	52.3	56.8	62.3	63.8	63.8	63.5	63.5
	500 Hz	48.1	51.6	57.3	61.9	63.7	63.3	63.8	63.8
	630 Hz	48.5	52.7	59.7	63.8	66.2	64.9	65.3	65.3
	800 Hz	55.3	54.4	62.6	67.2	70.1	68.0	68.9	68.9
	1000 Hz	49.6	53.3	62.5	66.7	69.8	68.2	68.2	68.2
	1250 Hz	47.7	52.8	62.4	66.5	70.2	68.7	69.0	69.0
	1600Hz	47.9	53.3	61.7	65.9	69.1	68.0	68.0	68.0
	2000 Hz	46.4	51.0	60.4	65.0	67.9	66.6	66.8	66.8
2500 Hz	44.7	49.7	60.3	65.2	67.5	66.6	67.1	67.1	
3150 Hz	43.0	47.9	59.5	63.9	67.9	66.2	66.3	66.3	
4000 Hz	39.7	44.4	57.9	62.7	66.3	64.9	64.8	64.8	
5000 Hz	35.3	40.7	54.2	59.7	63.4	61.7	61.8	61.8	
6300 Hz	29.6	35.4	49.3	55.1	58.7	57.4	57.4	57.4	
8000 Hz	23.9	30.5	44.4	50.9	54.8	53.3	53.1	53.1	
10000 Hz	18.4	24.2	38.6	45.9	50.3	48.2	48.2	48.2	
12500 Hz	14.5	18.0	31.8	39.1	43.9	41.6	41.9	41.9	
16000 Hz	24.2	24.3	26.4	30.9	35.2	33.4	33.3	33.3	

Model		HAHU-800-EC							
Speed		800RPM	900RPM	1000RPM	1100RPM	1200RPM	1300RPM	1350RPM	1400RPM
Sound Power dB(A)		65.1	68.4	76.2	81.1	83.7	82.7	82.6	82.8
Sound Power in 1/3 Octave-bands under ESP:120Pa (dB)	20 Hz	26.9	23.6	34.4	36.4	27.7	37.5	41.2	41.2
	25 Hz	18.4	25.3	28.1	28.1	30.5	32.6	31.9	31.9
	31.5 Hz	27.5	26.2	30.3	36.0	33.3	36.4	38.7	38.7
	40 Hz	29.5	31.8	35.7	37.1	39.9	38.2	41.3	41.3
	50 Hz	34.9	42.3	39.6	41.3	40.6	43.9	50.0	50.0
	63 Hz	39.4	41.1	46.2	49.0	49.5	50.6	49.7	49.7
	80 Hz	45.8	48.1	52.4	53.2	56.1	53.7	57.8	57.8
	100 Hz	44.1	50.3	52.5	57.8	60.9	59.4	62.0	62.0
	125 Hz	48.4	50.7	58.3	61.2	63.1	61.9	63.9	63.9
	160 Hz	49.1	53.1	57.1	63.1	66.3	64.1	63.1	63.1
	200 Hz	52.5	53.8	61.0	68.5	68.1	69.6	69.7	69.7
	250 Hz	53.0	57.6	62.0	66.7	68.0	68.8	67.1	67.1
	315 Hz	54.5	58.5	62.4	68.3	69.8	68.3	69.4	69.4
	400 Hz	53.7	56.8	61.3	66.8	68.3	68.3	68.0	68.0
	500 Hz	52.6	56.1	61.8	66.4	68.2	67.8	68.3	68.3
	630 Hz	53.0	57.2	64.2	68.3	70.7	69.4	69.8	69.8
	800 Hz	59.8	58.9	67.1	71.7	74.6	72.5	73.4	73.4
	1000 Hz	54.1	57.8	67.0	71.2	74.3	72.7	72.7	72.7
	1250 Hz	52.2	57.3	66.9	71.0	74.7	73.2	73.5	73.5
	1600Hz	52.4	57.8	66.2	70.4	73.6	72.5	72.5	72.5
	2000 Hz	50.9	55.5	64.9	69.5	72.4	71.1	71.3	71.3
	2500 Hz	49.2	54.2	64.8	69.7	72.0	71.1	71.6	71.6
	3150 Hz	47.5	52.4	64.0	68.4	72.4	70.7	70.8	70.8
	4000 Hz	44.2	48.9	62.4	67.2	70.8	69.4	69.3	69.3
5000 Hz	39.8	45.2	58.7	64.2	67.9	66.2	66.3	66.3	
6300 Hz	34.1	39.9	53.8	59.6	63.2	61.9	61.9	61.9	
8000 Hz	28.4	35.0	48.9	55.4	59.3	57.8	57.6	57.6	
10000 Hz	22.9	28.7	43.1	50.4	54.8	52.7	52.7	52.7	
12500 Hz	19.0	22.5	36.3	43.6	48.4	46.1	46.4	46.4	
16000 Hz	28.7	28.8	30.9	35.4	39.7	37.9	37.8	37.8	



### A.5. Dimensional Drawings

2 Pipe

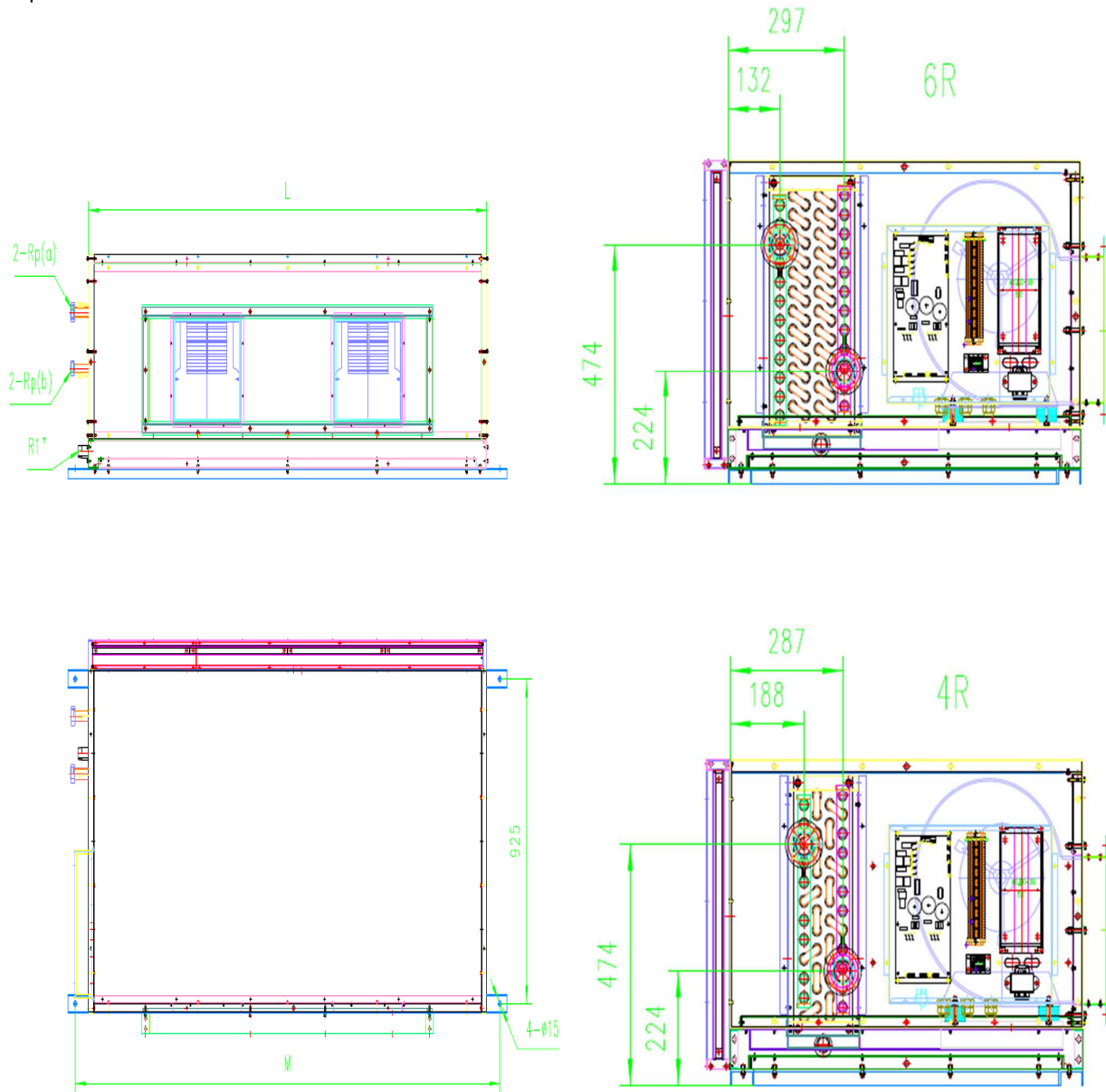

Model	L	M	Water Connection
HAHU-200	1080	1210	1-1/4"
HAHU-300	1280	1410	
HAHU-400	1480	1610	
HAHU-600	1680	1810	
HAHU-800	1980	2110	

All dimensions are in mm.

4 Pipe

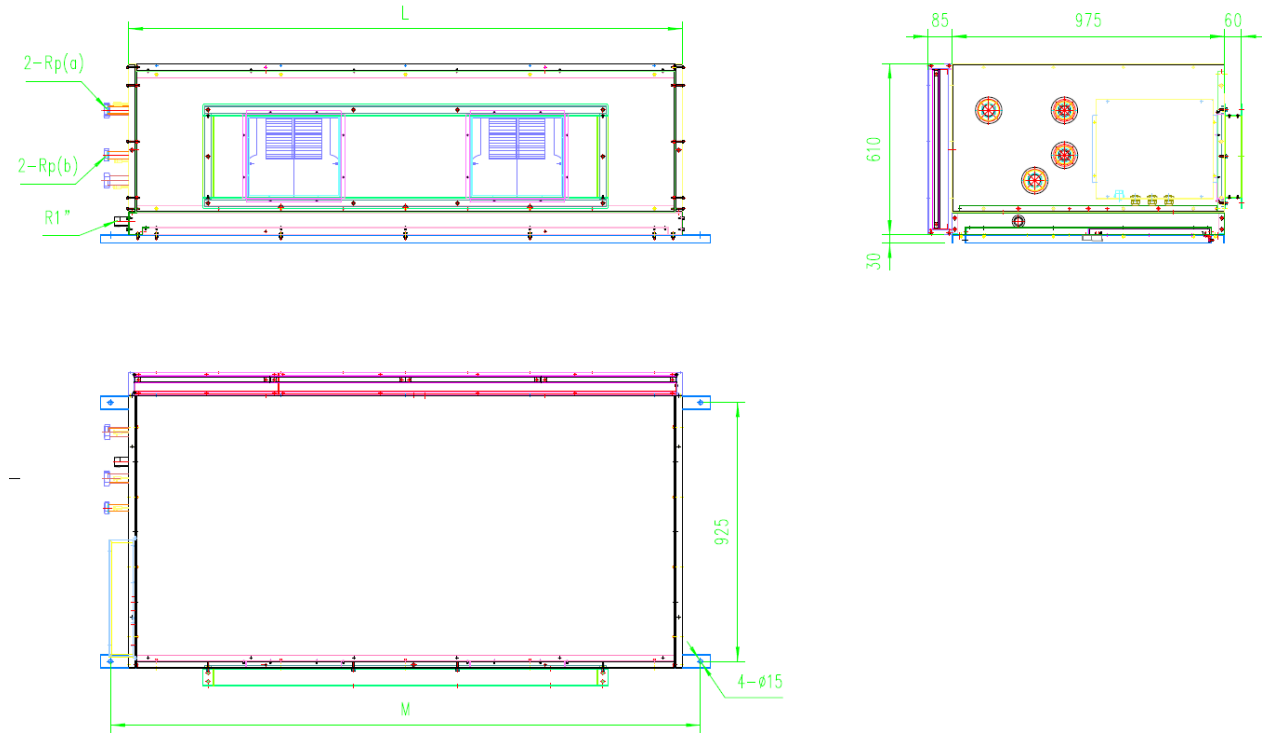

Model	L	M	Water Connection
HAHU-200	1080	1210	Cooling : 1-1/4\" Heating : 1\"
HAHU-300	1280	1410	
HAHU-400	1480	1610	
HAHU-600	1680	1810	
HAHU-800	1980	2110	

All dimensions are in mm.

## B. Installation

### B.1. Safety Precautions

- When installing, performing maintenance or servicing Polar Air fan coil units observe the precautions stated in this manual as well as those stated on the labels attached to the unit.
- Ensure all local and national safety codes, laws, regulations, as well as general electrical and mechanical safety guidelines are followed for installation, maintenance and service.
- The appliance is for indoor use only.
- Ensure the correct power supply is provided.
- If the power supply cord is damaged, it must be replaced by qualified personnel.
- Installing and servicing fan coil unit should be performed by qualified service personnel only.
- This appliance is not intended for use by persons (including children) with reduced physical, sensory or mental capabilities, or persons lacking in experience and knowledge of the appliance, unless they have been given supervision or instruction concerning it.
- User of this appliance is responsible for his/her own safety.
- Warranty shall be voided if installation instructions and safety precaution stated in this manual are not observed.
- Never cut off the mains supply when unit is under operation. The unit should only be switched off by using the ON-OFF button on the control interface.
- During connections, select pipe pliers according to pipe diameter to avoid damaging units over forced.
- Untreated frozen water and cooling water may cause dirt accumulation and corrosion. Suggest using treated water. Suggested working water pressure is below 1.6 Mpa.
- When units are in cooling mode, suggested freezing water degree is  $\geq 7^{\circ}\text{C}$ ; When units are in heating mode, suggested hot water degree is  $\leq 60^{\circ}\text{C}$ .
- Condensate water pipe, water connection pipe, water connectors and solenoid valve body must remain heat to avoid condensation.

#### **CAUTIONS**

*Before any service or maintenance operations turn off the mains electrical supply.*

*DO NOT turn OFF the main power supply when the unit is operating. Turn off the unit BEFORE turning off the main power*

## B.2. Location

Before installing and running the unit, please check the following:

1. There must be enough space for unit installation and maintenance. Please refer to below figure for the unit's outlines and dimensions and for the minimum distance between the unit and the obstacle/ any obstructions/ its surroundings.
2. Please ensure there is enough space for piping connections and electrical wiring.
3. Check whether the hanging rods can support the weight of the unit (see specification table for weight of the unit).
4. The unit must be installed horizontally to ensure proper operation and condensate draining.
5. The external static pressure of the ducting must be within the unit's static pressure range.
6. Confirm that the unit has been switched OFF before installing or servicing the unit.

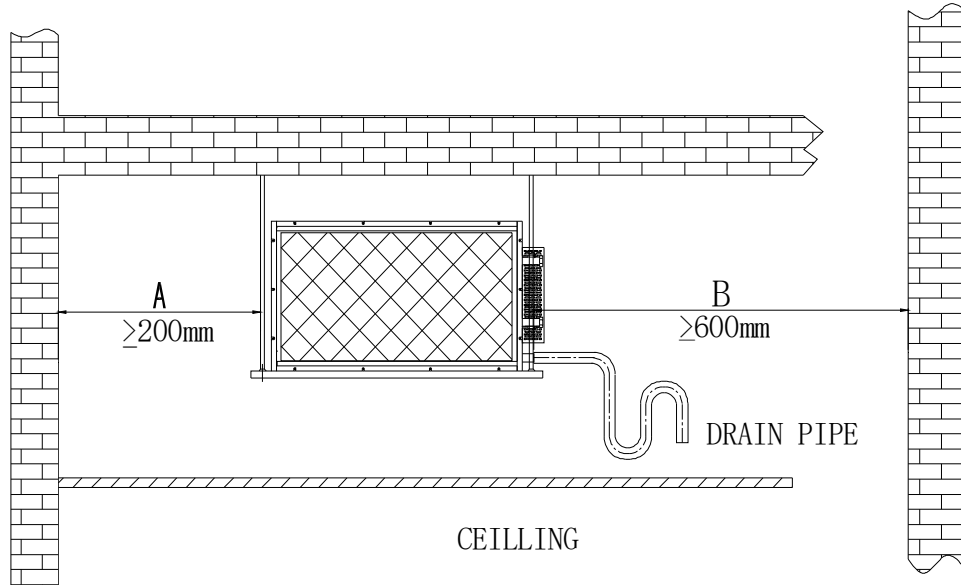

### B.3. Installation Procedures

1. The unit is designed to be installed in a concealed ceiling. Installation and maintenance should be performed by qualified personnel who are familiar with local codes and regulations, and are experienced with this type of appliance.
2. Please refer to the pictures below for installation procedure.

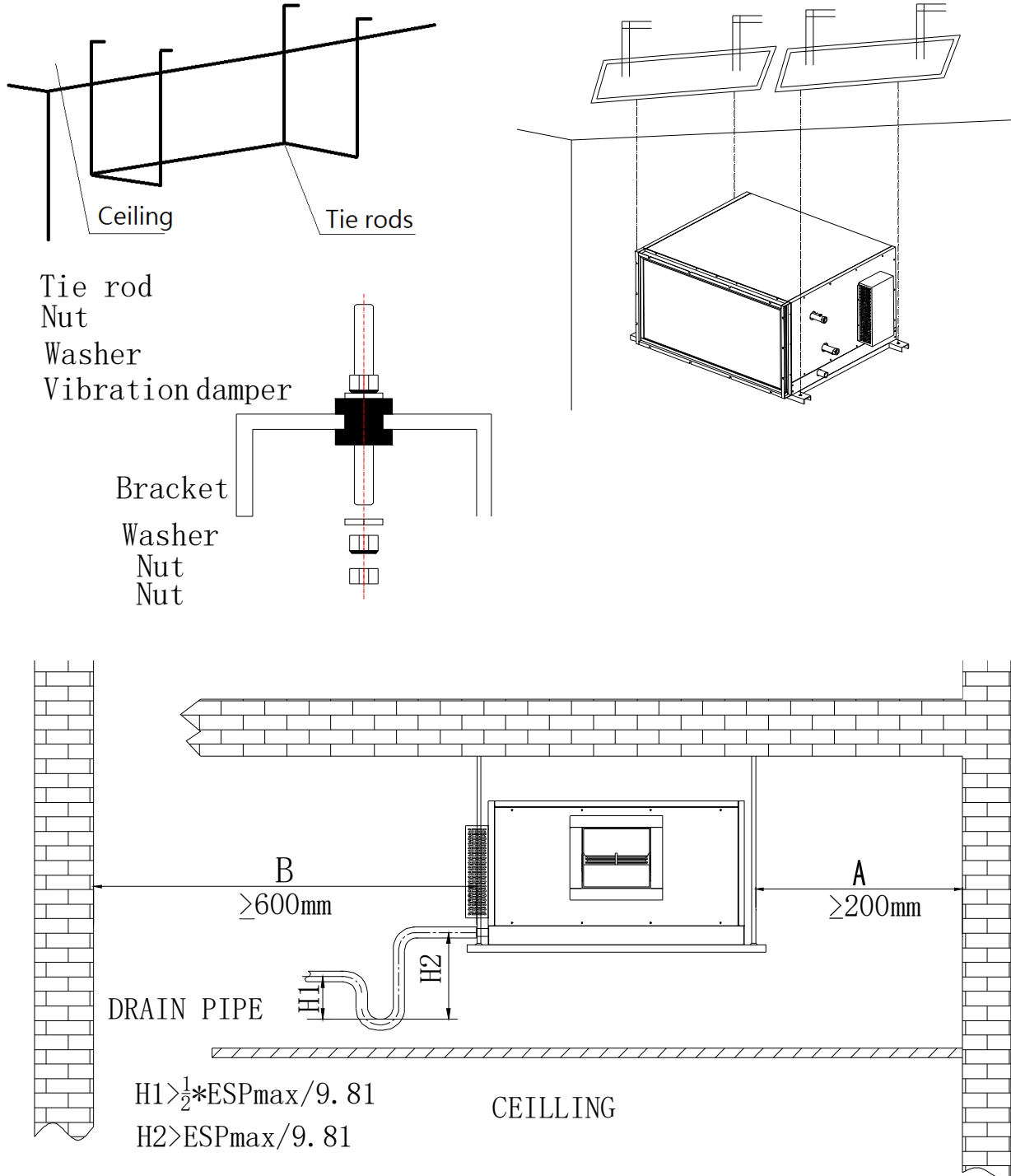

**CAUTIONS**

*Make sure the top of the unit is level after installation. The drain pan is designed with a slight gradient to facilitate drainage.*

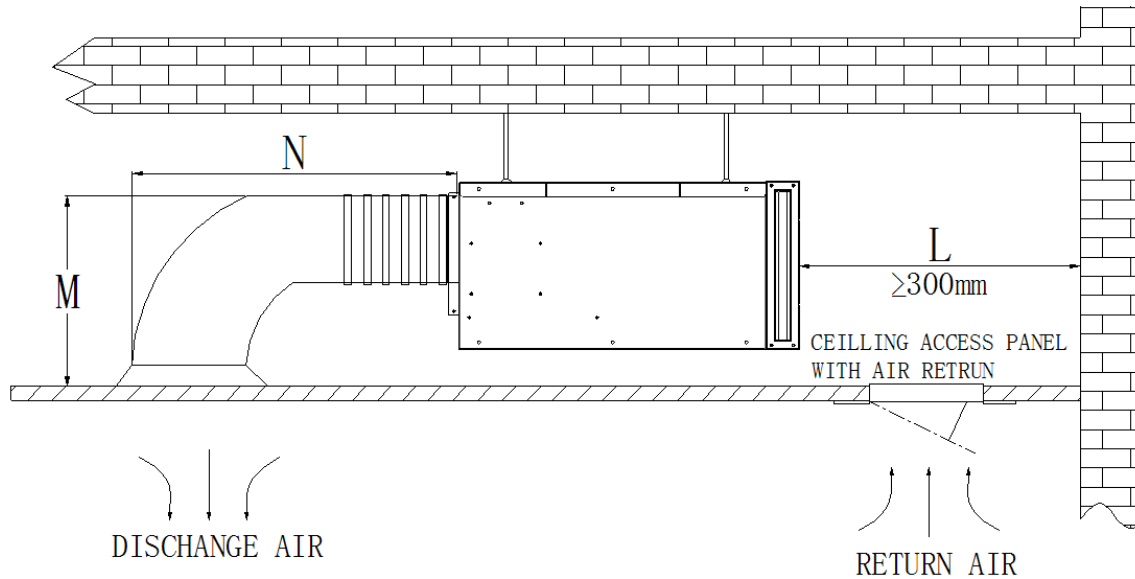

### CAUTIONS

*Dimension M and N are determined by air duct design.*

*Air duct should be fire-proof. Please refer to concerned country national and local regulation.*

*Circulatory air pressure drop should be approximately equal to the External Static Pressure.*

### B.4. Insulation

1. Confirm the Chilled water pipes and all parts on the pipes should be insulated.
2. Confirm insulation is installed on the supply air duct.

### B.5. Service Connection

1. Confirm duct connections are sealed.
2. Confirm water piping INLET is at the BOTTOM, water OUTLET is at the TOP.
3. Confirm no water leakage is observed at the piping and condensate drain connections.
4. Confirm drain pipe slope is minimum 1:50.

### CAUTIONS

*When connecting pipe to fan coil unit, do not bend or reposition the coil header for alignment purposes. This could cause a tubing fracture resulting in a water leak when water pressure is applied to the system.*

## B.6. Unit Operation

1. Confirm air has been properly bled from and there is waterflow through the coil.
2. Confirm fan wheel is rotating and air is discharged at unit supply opening.
3. Confirm power voltage between Terminals L1 and N.
4. Confirm thermostat voltage (24V or 12V).
5. Verify desired fan speed is receiving power from the thermostat.
6. Check functionality of motor with a call for heating or cooling.
7. Confirm system ESP is per schedule.
8. Confirm control valve(s) functionality.

## C. Maintenance

### C.1. General Maintenance

1. Installation and maintenance should be performed by qualified personnel who are familiar with local codes and regulations, and are also experienced with this type of appliance.
2. Confirm that the unit has been switched OFF before installing or servicing the unit.
3. A good general maintenance plan will prevent damage to and unexpected shutting down of the equipment.
4. Dirty filters reduce air flow as well as unit performance. Therefore, changing or cleaning the filters is important. Check the cleanliness of the filter and replace or clean as required monthly.
5. Coils should be cleaned with compressed air or water to remove dust, dirt or lint. They can be brushed with a soft brush or vacuumed with a vacuum cleaner.
6. If the water coil is not being used during the winter season it should be drained, or an anti-freezing solution should be added to the water circuit to avoid freezing.

### C.2. Regular Maintenance

1. Inspect and clean the condensate drain pan to avoid any clogging of the drain by dirt, dust, etc. Inspect drainage piping to ensure the proper condensate flow.
2. Check and clean the coil. Clean the coils with a low-pressure water jet or low-pressure air.
3. Clean and tighten all the wiring connections.
4. Drain out the water system and check for buildup of mineral deposits.

### C.3. Filter Cleaning

1. Remove the filter from the bottom
2. Clean the filter with a brush, or with water jet.
3. Reinstall the filter by sliding it back into the groove.

### C.4. Fan Motor Replacement

1. Remove the screws from the bottom panel.
2. Remove the fixing nuts of the fan blower.
3. Replace the fan
4. Reinstall the bottom panel with screws.

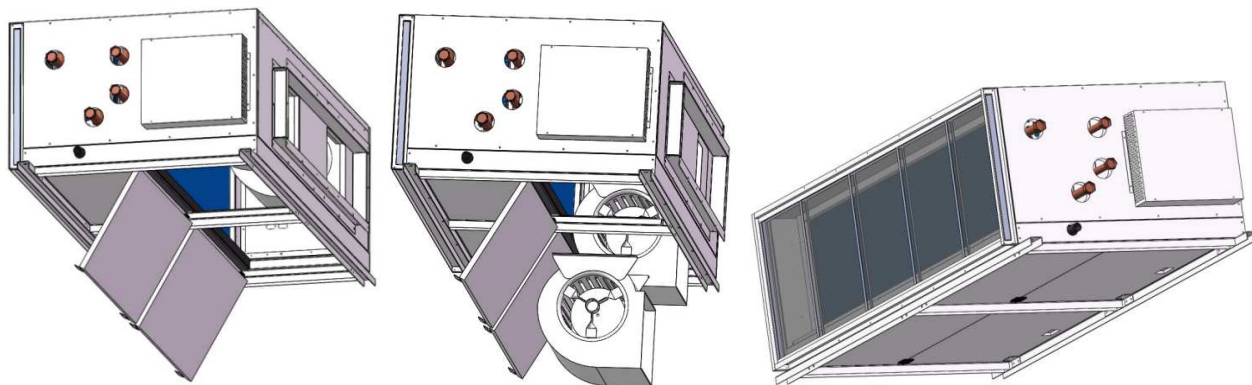

## D. Control Specifications: Intelligent Control (I Type)

### D.1. I/O Port Definitions for I type

I/O		Code	2-Pipe	4-Pipe
Analogue Input	Air Temperature Sensor	AL0	Room air temperature sensor (Tr)	
	Chilled water inlet sensor (Ti1)	AI1	Water inlet temperature sensor (Ti1)	Chilled water inlet temperature sensor (Ti1)
	Chilled water outlet sensor (Ti2)	AI2	Water outlet temperature sensor(Ti2)	Chilled water outlet temperature sensor(Ti2)
	Hot water inlet sensor (Ti3)	AI3	Air inlet temperature sensor (Ti3)	Hot water inlet temperature sensor (Ti3)
	Hot water outlet sensor (Ti4)	AI4	Air outlet temperature sensor (Ti4)	Hot water outlet temperature sensor (Ti4)
	Transducer signal input	0-10VDC		0-10VDC signal input
4-20mA1			4-20mA signal input1	
4-20mA2			4-20mA signal input2	
User interface	IR receiver	X-DIS 1	Digital communication port to LED / IR receiver board.	
	Wired wall pad	TTL1	Digital communication port to Wired wall pad board.	
Digital input	Occupancy contact	PRO1	The unit is ON. When occupancy contact is closed for 60s, the unit is turned OFF. When occupancy contact is open for 10s, the unit is turned ON.	
	Float switch	Float	NC signal for condensate water float switch.	
	EH protection	EH	NC signal for EH protection switch.	
Power supply	Working power supply	L	240VAC or 24VDC	
	GND	GND	Grounding	
Digital input	High speed	HF	High speed: Free of voltage contact	
	Medium speed	MF	Medium speed: Free of voltage contact	
	Low speed	LF	Low speed: Free of voltage contact	
	Motorized valve 1	MTV1	ON/OFF motorizes valve	Chilled water valve
	Motorized valve 2	MTV2	Reserved	Hot water valve
	Condensate water pump	WP	Condensate water pump: Free of voltage contact	
	Electrical heater	EH	EH: Free of voltage contact	
	BUS port	A1/B1	Communication with EC fan driver	
	BUS port	A/B	Modbus network serial connection	
	EC fan control signal	DA1	EC fan control signal 0-10VDC	
	Modulating valve 1	DA2	Modulating valve	Chilled water modulating valve
	Modulating valve 2	DA3	Modulating EH control signal	Hot water modulating valve



## D.2. Wiring Diagrams for I type

Intelligent Control Wiring Diagram for HAHU-200~400-EC

# EC-W4+S8 Wiring Diagram

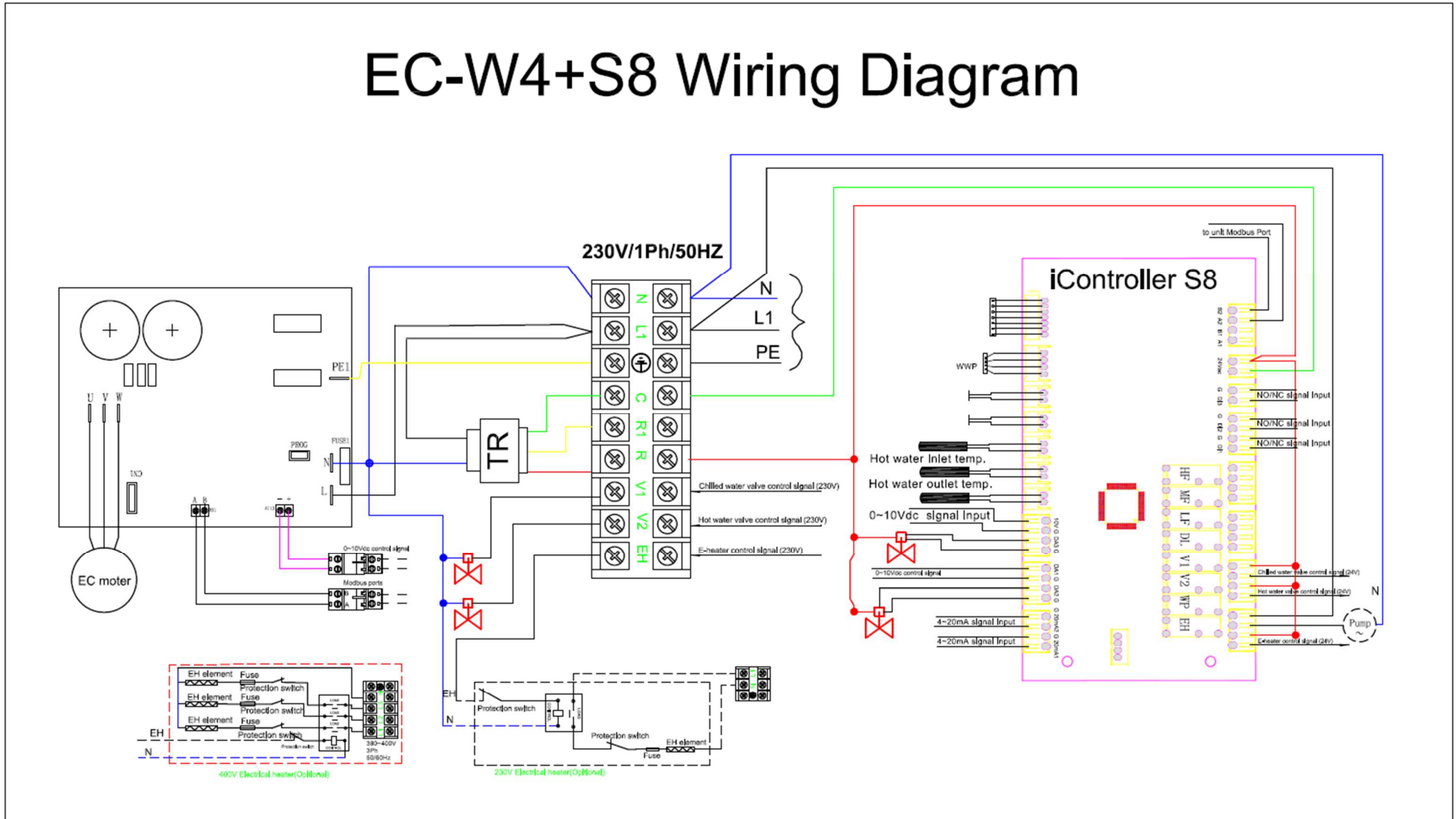

# EC-W5+S8 Wiring Diagram

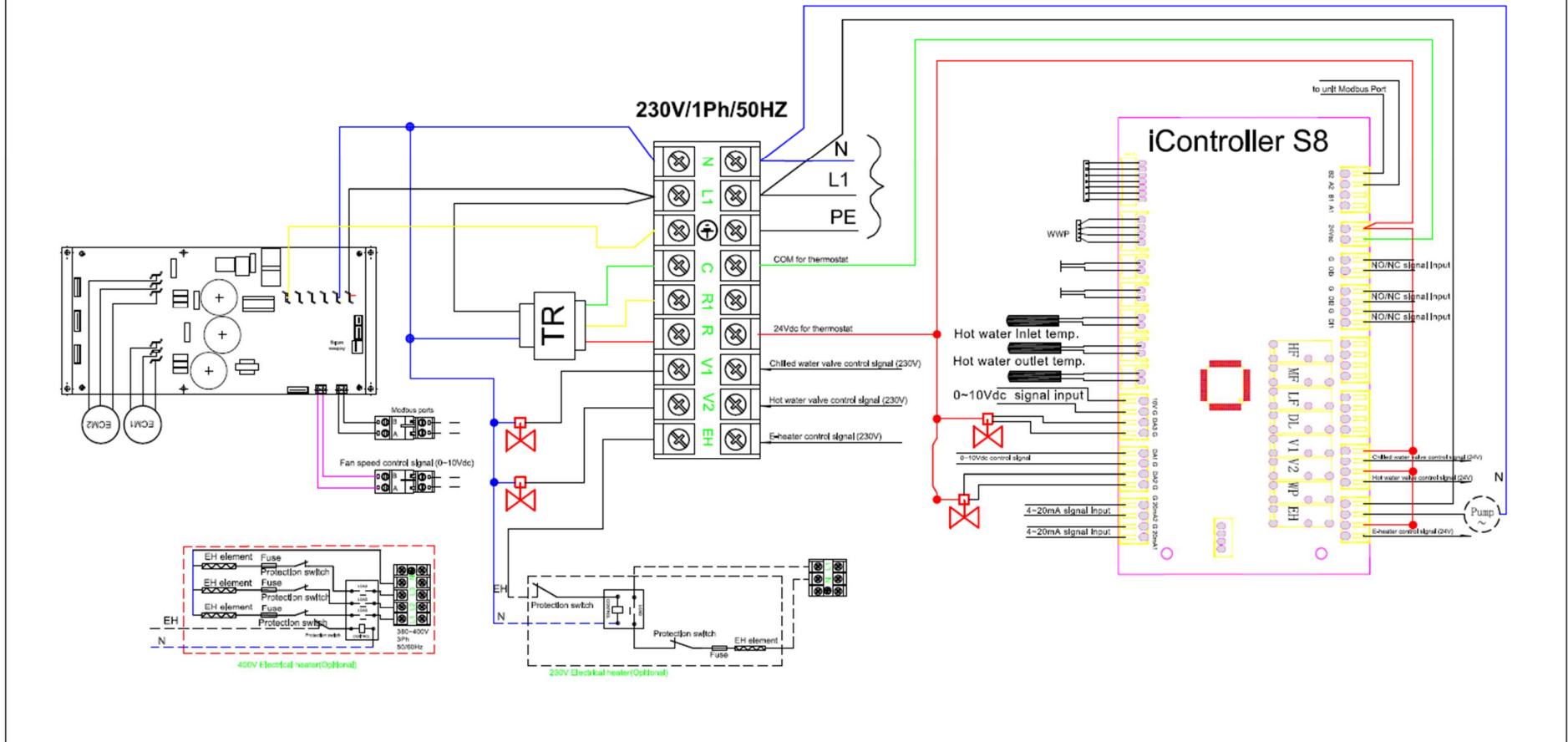

## D.3. Control Logics for I Control

### D.3.1. Control Logics for I Control For EC-S8 (300029=2)

#### 2-pipe with modulating valve for EC-S8 (300046=0)

##### **COOL MODE**

1) If  $Tr \geq Ts + 1$  °C, then cool operation is activated, MTV1 is turned on. Indoor fan runs at set speed. DA2 is open at 10Vdc for 2 min. Then check Ti1,

##### **MS300080=0,**

When  $Ti1 \leq 8$ °C, DA2 output is based on water temperature difference (Ti1/Ti2) and Modbus parameter 300027 setting PID calculation. The output is minimum output (Modbus300015 setting)-10VDC;

When  $8 < Ti1 \leq 10$ °C, DA2 output is based on water temperature difference (Ti1/Ti2) and Modbus parameter 300027 setting minus 1 PID calculation. The output is minimum output (Modbus300015 setting)-10VDC;

When  $10 < Ti1 \leq 12$ °C, DA2 output is based on water temperature difference (Ti1/Ti2) and Modbus parameter 300027 setting minus 2 PID calculation. The output is minimum output (Modbus300015 setting)-10VDC;

When  $12 < Ti1 \leq 15$ °C, DA2 output is based on water temperature difference (Ti1/Ti2) and Modbus parameter 300027 setting minus 3 PID calculation. The output is minimum output (Modbus300015 setting)-10VDC;

When  $15 < Ti1 \leq 28$ °C (Modbus 300017 setting), DA2 output is kept at 10Vdc;

When  $Ti1 > 28$ °C (Modbus 300017 setting), DA2 output is at minimum (Modbus300016 setting); and report pre-heat alarm

##### **MS300080=1,**

DA2 output is based on cooling water flow reading and setting PID calculation. The output is minimum output (Modbus300015 setting)-10VDC;

##### **MS300080=2,**

DA2 output is based on cooling pressure difference setting (MS300084) and 4-20mA input2 reading (MS400007) PID calculation. The output is minimum output (Modbus300015 setting)-10VDC;

2) If  $Tr < Ts - 1$  °C, then cool operation is terminated and MTV1 is turned off. DA2 is 0VDC. Indoor fan runs at set speed.

3) The range of Ts is 16 - 30 °C or fixed according to Parameter 4 setting.

4) Indoor fan speed can be adjusted for low, medium, high and auto.

##### **LOW TEMPERATURE PROTECTION OF INDOOR COIL**

a) If  $Ti1 \leq 2$  °C for 2 minutes, then MTV1 is turned off; DA2=0VDC; If indoor fan is set for low speed, then it will run at medium speed. If it is set at medium or high speed, then it will keep running at the same speed.

b) If  $Ti1 \geq 5$ °C for 2 minutes, then MTV1 is turned on. DA2 is calculated by delta T; Indoor fan runs at set speed.

##### **FAN MODE**

a) Indoor fan runs at the set speed while heater, MTV1, MTV2 are turned off.

b) Indoor fan speed can be adjusted to low, medium and high.

##### **HEAT MODE**

##### **Heat mode without electrical heater (300047=0)**

a) If  $Tr \leq Ts - 1$  °C, then heat operation is activated and MTV1 and MTV2 are turned on.

DA2 is open at 10Vdc for 2 min. Then check Ti1,

##### **MS300080=0,**

If  $Ti1 \leq 28$ °C (300017 setting), fan is turned on at low speed; DA2 is on at 10VDC;

If  $28^{\circ}\text{C}$  (300017 setting)  $< \text{Ti1} < 28$  (3000017 setting)  $+ 4^{\circ}\text{C}$ , fan and DA2 are kept original state;

If  $\text{Ti1} \geq 28$  (3000017 setting)  $+ 4^{\circ}\text{C}$ , fan runs at set speed. DA2 output is from minimum setting (300016 setting) - 10Vdc based on Delta Ti and setting; if Ti sensor is damaged, Fan runs at set speed.

**MS300080=1,**

DA2 output is based on heating water flow reading and setting PID calculation. The output is minimum output (Modbus300015 setting)-10VDC;

**MS300080=2,**

DA2 output is based on heating pressure difference setting (MS300085) and 4-20mA input2 reading (MS400007) PID calculation. The output is minimum output (Modbus300015 setting)-10VDC;

b) If  $\text{Tr} > \text{Ts} + 1^{\circ}\text{C}$ , then heat operation is terminated and MTV1 is turned off. DA2 is 0VDC. Indoor fan is turned OFF.

c) The range of Ts is 16 - 30°C or fixed according to Parameter 4 setting.

d) Indoor fan speed can be adjusted to low, medium, high and auto.

**Heat mode with electrical heater as booster (300047=1)**

a) If  $\text{Tr} \leq \text{Ts} - 1^{\circ}\text{C}$ , then heat operation is activated and MTV1 and MTV2 are turned on. Indoor fan runs at the set speed.

DA3 output is from minimum setting (300016 setting) - 10Vdc based on Delta T3/T4 and setting; DA2 is open at 10VDC for 2 min. Then check Ti1;

**MS300080=0,**

If  $\text{Ti1} \leq 28^{\circ}\text{C}$  (300017 setting), EH is closed; DA2 output is 10Vdc; DA3 output is from 0 - 10Vdc based on Delta Ti3/Ti4 and setting;

If  $28^{\circ}\text{C}$  (300017 setting)  $< \text{Ti1} \leq 28^{\circ}\text{C}$  (300017 setting)  $+ 4^{\circ}\text{C}$ , EH and DA2 output are kept original state;

If  $\text{Ti1} > 28^{\circ}\text{C}$  (300017 setting)  $+ 4^{\circ}\text{C}$ , EH is opened; DA3 is 0Vdc; DA2 output is from minimum setting (300016 setting) - 10Vdc based on Delta Ti1/Ti2 and setting;

**MS300080=1**

DA2 output is based on heating water flow reading and setting PID calculation. The output is minimum output (Modbus300015 setting)-10VDC;

If  $\text{Ti1} \leq 28^{\circ}\text{C}$  (300017 setting), EH is closed;

If  $28^{\circ}\text{C}$  (300017 setting)  $< \text{Ti1} \leq 28^{\circ}\text{C}$  (300017 setting)  $+ 4^{\circ}\text{C}$ , EH is kept original state;

If  $\text{Ti1} > 28^{\circ}\text{C}$  (300017 setting)  $+ 4^{\circ}\text{C}$ , EH is opened;

**MS300080=2**

DA2 output is based on heating pressure difference setting (MS300085) and 4-20mA input2 reading (MS400007) PID calculation. The output is minimum output (Modbus300015 setting)-10VDC;

If  $\text{Ti1} \leq 28^{\circ}\text{C}$  (300017 setting), EH is closed;

If  $28^{\circ}\text{C}$  (300017 setting)  $< \text{Ti1} \leq 28^{\circ}\text{C}$  (300017 setting)  $+ 4^{\circ}\text{C}$ , EH is kept original state;

If  $\text{Ti1} > 28^{\circ}\text{C}$  (300017 setting)  $+ 4^{\circ}\text{C}$ , EH is opened;

b) If  $\text{Tr} > \text{Ts} + 1^{\circ}\text{C}$ , then heat operation is terminated and MTV1 and MTV2 are turned off. DA2 is 0VDC. Indoor fan runs at auto speed;

c) The range of Ts is 16 - 30°C or fixed according to Parameter 4 setting;

d) Indoor fan speed can be adjusted for low, medium, high and auto.

**Heat mode with electrical heater as primary heat source (300047=2)**

a) If  $\text{Ti2} \leq 35^{\circ}\text{C}$  (or Ti2 is damaged or disconnected), and if  $\text{Tr} \leq \text{Ts} - 1^{\circ}\text{C}$  (or  $-4^{\circ}\text{C}$  if economy contact is closed), heat operation is

activated, Indoor fan runs at set speed. EH is turned on. DA3 output is from minimum setting(300016setting) - 10Vdc based on Delta T3 /T4 and setting;

- b) If  $T_r > T_s + 1$  °C then heat operation is terminated, Electrical heater is OFF. Indoor fan is turn OFF after 120S.
- c) The range of  $T_s$  is 16-30 °C or fixed according to Parameter 4 setting.
- d) Indoor fan speed can be adjusted for low, medium, high and auto.

#### OVER-HEAT PROTECTION OF INDOOR COIL IN HEAT MODE

- a) If  $T_{i1} \geq 75$  °C, then MTV1, DA2, MTV2 and EH are turned off, indoor fan runs at high speed, even in standby mode.
  - b) If  $T_{i1} < 70$  °C, then unit will maintain its original state.
- If  $T_{i1}$  temperature sensor is damaged, the protection mode will be override.

#### DEHUMIDIFICATION MODE

- a)  $T_s = 24$ °C;
- b) If  $T_r \geq 25$ °C for 30S, then MTV1 will be ON for 3 minutes, and then OFF for 4 minutes. DA2 is turned on 3times of minimum opening. Fan is running at auto speed.
- c) If  $16$ °C  $\leq T_r < 25$ °C, then MTV1 will be ON for 3 minutes, and then OFF for 6 minutes. DA2 is turned on 2 times of minimum opening. Fan is running at auto speed.
- d) If  $T_r < 16$ °C, then MTV1 will be turned ON for 4 minutes and then OFF for 10 minutes. DA2 is turned on minimum opening. Fan is running at auto speed.

#### AUTOMODE

Fan is turned on at medium speed. Check  $T_r$  and  $T_s$  in 30S;

if  $T_s > T_r + 3$ °C for 30S, the unit is turned on in heat mode;

if  $T_r - 3$  °C  $< T_s < T_r + 3$  °C for 30S, the unit is turned on in fan mode;

If  $T_s < T_r - 3$  °C, , the unit is turned on in cool mode;

If the unit working mode is confirmed, it cannot change. After unit is turned OFF for 2 hours, then working mode is reset again.

#### 4-pipe with modulating valve for EC-S8 (300046=1)

##### COOL MODE

- 1) If  $T_r \geq T_s + 1$  °C, then cool operation is activated, MTV1 is turned on. Indoor fan runs at set speed.  
DA2 is open at 10Vdc for 2 min. Then check  $T_{i1}$ ,

##### MS300080=0,

When  $T_{i1} \leq 8$ °C, DA2 output is based on water temperature difference ( $T_{i1}/T_{i2}$ ) and Modbus parameter 300027 setting PID calculation. The output is minimum output (Modbus300015 setting)-10VDC;

When  $8 < T_{i1} \leq 10$ °C, DA2 output is based on water temperature difference ( $T_{i1}/T_{i2}$ ) and Modbus parameter 300027 setting minus 1 PID calculation. The output is minimum output (Modbus300015 setting)-10VDC;

When  $10 < T_{i1} \leq 12$ °C, DA2 output is based on water temperature difference ( $T_{i1}/T_{i2}$ ) and Modbus parameter 300027 setting minus 2 PID calculation. The output is minimum output (Modbus300015 setting)-10VDC;

When  $12 < T_{i1} \leq 15$ °C, DA2 output is based on water temperature difference ( $T_{i1}/T_{i2}$ ) and Modbus parameter 300027 setting minus 3 PID calculation. The output is minimum output (Modbus300015 setting)-10VDC;

When  $15 < T_{i1} \leq 28$ °C (Modbus 300017 setting), DA2 output is kept at 10Vdc;

When  $T_{i1} > 28$ °C (Modbus 300017 setting), DA2 output is at minimum (Modbus300016 setting); and report pre-heat alarm;

##### MS300080=1

DA2 output is based on cooling water flow reading and setting PID calculation. The output is minimum output (Modbus300015 setting)-10VDC;

##### MS300080=2

DA2 output is based on cooling pressure difference setting (MS300084) and 4-20mA input2 reading (MS400007) PID calculation. The output is minimum output (Modbus300015 setting)-10VDC;

- 2) If  $T_r < T_s - 1$ °C, then cool operation is terminated and MTV1 and AUX1 are turned off. DA2 is 0VDC. Indoor fan runs at set

speed.

3) The range of  $T_s$  is 16 - 30 °C.

4) Indoor fan speed can be adjusted for low, medium, high and auto.

#### LOW TEMPERATURE PROTECTION OF INDOOR COIL

a) If  $T_{i1} \leq 2$  °C for 2 minutes, then MTV1 is turned off. DA2=0VDC. If indoor fan is set for low speed, then it will run at medium speed. If it is set at medium or high speed, then it will keep running at the same speed.

a) If  $T_{i1} \geq 5$ °C for 2 minutes, then MTV1 is turned on. DA2 is calculated by delta T. Indoor fan runs at set speed.

#### FAN MODE

a) Indoor fan runs at the set speed while heater, MTV1, MTV2, AUX1 and AUX1 are turned off.

b) Indoor fan speed can be adjusted to low, medium and high.

#### HEAT MODE

##### Heat mode without electrical heater (300047=0)

a) If  $T_r \leq T_s - 1$  °C, then heat operation is activated and MTV2 is turned on.

DA3 is open at 10Vdc for 2 min. Then check  $T_{i3}$ ,

##### **MS300080=0,**

If  $T_{i3} \leq 28$ °C (300017 setting), fan is turned on at low speed; DA3 is on at 10VDC;

If  $28$ °C (300017 setting)  $< T_{i3} < 28$  (3000017 setting) +4°C, fan and DA3 are kept original state;

If  $T_{i3} \geq 28$  (3000017 setting) +4°C, fan runs at set speed. DA3 output is from minimum setting(300016setting) - 10Vdc based on Delta T3 and T4 and setting; if  $T_{i1}$  sensor is damaged, Fan runs at set speed.

##### **MS300080=1**

DA3 output is based on heating water flow reading and setting PID calculation. The output is minimum output (Modbus300015 setting)-10VDC;

##### **MS300080=2**

DA3 output is based on heating pressure difference setting (MS300085) and 4-20mA input 3 reading (MS400008) PID calculation. The output is minimum output (Modbus300015 setting)-10VDC;

b) If  $T_r > T_s + 1$  °C then heat operation is terminated and MTV2 is turned off. DA3 is 0VDC. Indoor fan is turned on low speed;

c) The range of  $T_s$  is 16 - 30°C.

d) Indoor fan speed can be adjusted to low, medium, high and auto.

#### OVER-HEAT PROTECTION OF INDOOR COIL IN HEAT MODE

a) If  $T_{i3} \geq 75$  °C, then MTV2, DA3, AUX2 and EH are turned off, indoor fan runs at high speed, even in standby mode.

b) If  $T_{i3} < 70$  °C, then unit will maintain its original state.

c) If  $T_{i3}$  temperature sensor is damaged, the protection mode will be overridden

#### DEHUMIDIFICATION MODE

a)  $T_s = 24$ °C;

b) If  $T_r \geq 25$ °C for 30S, then MTV1 will be ON for 3 minutes, and then OFF for 4 minutes. DA2 is turned on 3 times of minimum opening. Fan is running at auto speed.

c) If  $16$ °C  $\leq T_r < 25$ °C, then MTV1 will be ON for 3 minutes, and then OFF for 6 minutes. DA2 is turned on 2 times of minimum opening. Fan is running at auto speed.

d) If  $T_r < 16$ °C, then MTV1 will be turned ON for 4 minutes and then OFF for 10 minutes. DA2 is turned on minimum opening. Fan is running at auto speed.

#### AUTOMODE

Fan is turned on at medium speed. Check  $T_r$  and  $T_s$  in 30S;

if  $T_s > T_r + 3$ °C for 30S, the unit is turned on in heat mode;

if  $T_r - 3$  °C  $< T_s < T_r + 3$  °C for 30S, the unit is turned on in fan mode;

If  $T_s < T_r - 3$  °C, , the unit is turned on in cool mode;

If unit is working at heat mode or Fan mode, if  $T_r - T_s > 3.0$ °C, MTV2 , MTV1 and DA3 are OFF more than 3 minutes, working mode will be changed to cooling mode;

If unit is working at cool mode or Fan mode, if  $T_s - T_r > 3.0^\circ\text{C}$ , MTV2, MTV1 and DA2 are OFF more than 3 minutes, working mode will be changed to heating mode;

#### 2-pipe with 6-way valve unit for EC-S8 (300046=2)

##### **COOL MODE**

1) If  $T_r \geq T_s + 1^\circ\text{C}$ , then cool operation is activated, MTV1 is turned on. Indoor fan runs at set speed.

DA2 is open at 0Vdc for 2 min. Then check Ti1,

##### **MS300080=0,**

When  $T_{i1} \leq 8^\circ\text{C}$ , DA2 output is based on water temperature difference ( $T_{i1}/T_{i2}$ ) and Modbus parameter 300027 setting PID calculation. The output is 4-0Vdc;

When  $8 < T_{i1} \leq 10^\circ\text{C}$ , DA2 output is based on water temperature difference ( $T_{i1}/T_{i2}$ ) and Modbus parameter 300027 setting minus 1 PID calculation. The output is 4-0Vdc;

When  $10 < T_{i1} \leq 12^\circ\text{C}$ , DA2 output is based on water temperature difference ( $T_{i1}/T_{i2}$ ) and Modbus parameter 300027 setting minus 2 PID calculation. The output is 4-0Vdc;

When  $12 < T_{i1} \leq 15^\circ\text{C}$ , DA2 output is based on water temperature difference ( $T_{i1}/T_{i2}$ ) and Modbus parameter 300027 setting minus 3 PID calculation. The output is 4-0Vdc;

When  $15 < T_{i1} \leq 28^\circ\text{C}$  (Modbus 300017 setting), DA2 output is kept at 0Vdc;

When  $T_{i1} > 28^\circ\text{C}$  (Modbus 300017 setting), DA2 output is 4Vdc; and report pre-heat alarm;

##### **MS300080=1**

DA2 output is based on cooling water flow reading and setting PID calculation. The output is minimum output The output is 4-0Vdc;

##### **MS300080=2**

DA2 output is based on cooling pressure difference setting (MS300084) and 4-20mA input2 reading (MS400007) PID calculation. The output is 4-0Vdc.

2) If  $T_r < T_s - 1^\circ\text{C}$ , then cool operation is terminated and MTV1 is turned off. DA2 is 5VDC. Indoor fan runs at set speed.

3) The range of  $T_s$  is 16 - 30  $^\circ\text{C}$ .

4) Indoor fan speed can be adjusted for low, medium, high and auto.

##### **LOW TEMPERATURE PROTECTION OF INDOOR COIL**

a) If  $T_{i1} \leq 2^\circ\text{C}$  for 2 minutes, then MTV1 is turned off. DA2=5VDC; If indoor fan is set for low speed, then it will run at medium speed. If it is set at medium or high speed, then it will keep running at the same speed.

b) If  $T_{i1} \geq 5^\circ\text{C}$  for 2 minutes, then MTV1 is turned on. DA2 is calculated by Delta T; Indoor fan runs at set speed.

##### **FAN MODE**

a. Indoor fan runs at the set speed while heater, MTV1, MTV2 are turned off.

b. Indoor fan speed can be adjusted to low, medium and high.

##### **HEAT MODE**

##### **Heat mode without electrical heater (300047=0)**

b) If  $T_r \leq T_s - 1^\circ\text{C}$ , then heat operation is activated and MTV2 is turned on. DA2 is open at 10Vdc for 2 min. Then check Ti1.

##### **MS300080=0,**

If  $T_{i1} \leq 28^\circ\text{C}$  (300017 setting), fan is turned on at low speed; DA2 is on at 10VDC;

If  $28^\circ\text{C}$  (300017 setting)  $< T_{i1} < 28$  (3000017 setting)  $+ 4^\circ\text{C}$ , fan and DA2 are kept original state;

If  $T_{i1} \geq 28$  (3000017 setting)  $+ 4^\circ\text{C}$ , fan runs at set speed. DA2 output is from 6 - 10Vdc based on Delta  $T_{i1}/T_{i2}$  and setting; if Ti sensor is damaged, Fan runs at set speed.

##### **MS300080=1**

DA2 output is based on heating water flow reading and setting PID calculation. The output is from 6-10Vdc;

##### **MS300080=2**

DA2 output is based on heating pressure difference setting (MS300085) and 4-20mA input2 reading (MS400007) PID calculation. The output is from 6-10Vdc;

b) If  $T_r > T_s + 1^\circ\text{C}$ , then heat operation is terminated and MTV1 is turned off. DA2 is 5VDC. Indoor fan is turned OFF.

- c) The range of Ts is 16 - 30°C.
- d) Indoor fan speed can be adjusted to low, medium, high and auto.

#### DEHUMIDIFICATION MODE

- a) MTV1 is turned on; Ts=24°C;
- b) If Tr ≥ 25°C for 30S, DA2 is 1.5Vdc. Fan is running at auto speed.
- c) If 16°C ≤ Tr < 25°C, DA2 is 2.5Vdc. Fan is running at auto speed.
- d) If Tr < 16°C, DA2 is 3.5Vdc. Fan is running at auto speed.

#### AUTOMODE

Fan is turned on at medium speed. Check Tr and Ts in 30S;

if Ts > Tr + 3°C for 30S, the unit is turned on in heat mode;

if Tr - 3 °C < Ts < Tr + 3 °C for 30S, the unit is turned on in fan mode;

If Ts < Tr - 3 °C, the unit is turned on in cool mode;

If the unit working mode is confirmed, it cannot change.

#### FOR 2-PIPE AND 4-PIPE SYSTEMS

##### PRO (N/O signal input)

##### When Modbus 100004=0;

The unit is on:

PRO input is closed for 60S, the unit is turned off.

PRO input is open for 60S, the unit is turned on.

##### When Modbus 100004=1;

1) The unit is on or standby, PRO input is open or closed, the unit is kept original state;

2) The unit is off,

PRO input is closed for 30S, MTV1 is turned on, DA2 is open at double of minimum setting (Modbus 300027 setting), Fan is turn on at low speed;

PRO input is opened for 30S, MTV1 is off, DA2 is 0Vdc, Fan is turn off.

3) In period of PRO closed time, if unit receives instruction from remote handset, wired wall pad or Modbus, the unit will work according to the instruction at once.

#### SLEEP MODE

SLEEP mode can only be set when the unit is in COOL or HEAT mode.

In COOL mode, after SLEEP mode is set, the indoor fan will run at auto speed and Ts will increase by 0.5 °C for every 30mins.

In HEAT mode, after SLEEP mode is set, the indoor fan will run at auto speed and Ts will decrease by 0.5 °C for every 30 minutes.

Sleep mode is turned off, the setting temperature resumes and Fan is changed to setting speed.

#### DA1 0-10vdc control signals

DA1 output is set by 300022 when fan is set at high speed

DA1 output is set by 300021 when fan is set at medium speed;

DA1 output is set by 300020 when fan is set at low speed;

When fan is set auto mode, if 300048=0, DA1 output is calculated by Tr/Ts PID calculation. If 300048=1, DA1 output is calculated by ESP PID calculation.

#### DRAIN PUMP (IF INSTALLED)

In cooling mode, if MTV1 is turned ON, WP is turned ON. If MTV1 is turned OFF or unit working mode is changed, WP will be turned OFF after 5 minutes.

If the system is turned off at the circuit breaker (or main power supply), the drain pump function is off.

#### FLOAT SWITCH (IF INSTALLED)



If the float switch (N/C) is opened before the unit is turned on and if running at COOL mode, then MTV1 is turned off. The drain pump will be turned on and indoor fan will keep running. After float switch is closed, MTV1 is turned on.

If the unit is turned on in COOL mode and the float switch is opened continuously  $\geq 5$  seconds, then the drain pump will be turned on and MTV1 will remain off. After the float switch is closed, the drain pump will run for an additional 5 minutes. If the float switch is opened for 10 minutes continuously, then MTV1 will remain off and the indoor fan runs at set speed and the system will report an error signal.

If the unit is off and the float switch is opened, then the drain pump will be turned on. After the float switch is closed, the drain pump will run for an additional 5 minutes. If the float switch is opened for 10 minutes continuously, then the system will report an error signal.

#### **EH PROTECTION SWITCH**

1. If EH protection switch is closed for 30s and Fan is ON, then EH is ON.
2. When EH is ON, EH protection is open for 1s, or Fan is OFF, EH will be turned OFF at once and report alarm.
3. When EH protection switch is closed for 180s, EH will be turned ON again.
4. If EH protection switch is opened 3 times in 1 hour, EH will not be turned ON again except main power reset.

#### **LOW TEMPERATURE PROTECTION OF INDOOR COIL IN WINTER**

This is frost protection when the unit is off to prevent water from freezing in the coil.

If a 2-pipe system is in Standby Mode, when  $Tr \leq 2$  °C for 2 minutes, MTV1 is turned on. AUX2 is on. DA2 is 5VDC. If  $Ti1 < 5$ °C for 2 minutes, EH (if installed) is switched on. Indoor fan is turned on at low speed. If  $Tr \geq 5$ °C for 2 minutes, MTV2 is turned off. AUX2 is off. DA2 is 0VDC. EH (if installed) is turned off. Indoor fan is switched off.

If a 4-pipe system (or 2-pipe unit with 6-way valve) is in Standby Mode, when  $Tr \leq 2$  °C for 2 minutes, MTV2 is turned on. AUX2 is on. DA3 is 5VDC (DA2 is 8VDC if using 6-way valve). If  $Ti1 < 5$ °C for 2 minutes EH (if installed) is switched on. Indoor fan is turned on at low speed. If  $Tr \geq 5$ °C for 2 minutes, MTV2 is turned off. AUX2 is off. DA3 is 0VDC (DA2 is 5VDC if using 6-way valve). EH (if installed) is turned off. Indoor fan is switched off.

## D.4. Open Modbus Protocol

### D.4.1. Open Modbus Protocol For EC-S8

Transfer Mode: RTU, BAUD Rate: 9600bps, 8 data bit, 1 stop bit, None parity bit

The communications require a delay of 80ms between reading an answer and sending the next command. All temperatures are equal to reading data\*10 accuracy: 0.1 degree C.

Supported Functions:

Function Code	Function Description
01(01H)	Read Coils
02(02H)	Read Discrete Inputs
03(03H)	Read Holding Registers
04(04H)	Read Input Registers
05(05H)	Write Single Coil
06(06H)	Write Single Register
15(0FH)	Write Multiple Coils
16(10H)	Write Multiple Registers
255(FFH)	Extended Commands which are used to test unit

Valid Error code table:

Error code	Description	Definition
01 (01H)	Invalid commands	Received commands beyond valid commands
02 (02H)	Invalid data address	Data addresses beyond valid data address
03 (03H)	Invalid data	Data beyond definition range
04 (04H)	Write data not successful	Write data did not succeed

Coils table:

Description	Address	Type*	Remark
ON/OFF	100000	R/W	
Sleeping mode	100001	R/W	
Louver swings	100002	R/W	
Energy Saving Mode	100003	R/W	
PRO function	100004	R/W	

Discrete table:

Description	Address	Type*	Remark
MTV1	200000	R	
MTV2	200001	R	
Reserved	200002	R	
Reserved	200003	R	
Condensate pump	200004	R	
Electrical heater	200005	R	
Wired wall pad	200006	R	
PR-O1	200007	R	
Float switch	200008	R	
Reserved	200009	R	
EH safety switch	200010	R	
Internal test	200011	R	Testing purpose only.
Reserved	200012	R	
Reserved	200013	R	
Reserved	200014	R	
Reserved	200015	R	
Reserved	200016	R	
Reserved	200017	R	
Reserved	200018	R	
Reserved	200019	R	

\* R = read only, W = write only, R/W = read and write.

Holding Register table:

Description	Address	Type*	Remark
Mode setting	300000	R/W	Cooling mode = 01(H) Humidify mode = 02(H) Fan mode = 04(H) Heating mode = 08(H) Auto mode = 10(H)
Fan speed setting	300001	R/W	Low speed = 04(H) Medium speed = 02(H) High speed = 01(H) Auto fan speed = 07(H)
Louver swing setting	300002	R/W	Position 1=01(H)
			Position2=02(H)
			Position3=03(H)
			Position4=04(H)
			Auto=0F(H)
Stop=00(H)			
Setting temperature	300003	R/W	16-30 (actual*10 format)
Address setting	300004	R/W	1-255
Reset	300005	W	=0x33 reset error
Week	300006	W	
Hour	300007	W	
Minute	300008	W	
Second	300009	W	
Hours in Timer on	300010	R/W	Timer ON
Minute in Timer on	300011	R/W	Timer ON
Hours in Timer off	300012	R/W	Timer OFF
Minute in Timer off	300013	R/W	Timer OFF
Icon of Timer ON or OFF	300014	R/W	BIT0 = Icon of Timer ON BIT1 = Icon of Timer OFF 1 = enable 0 = disable
Minimum outputDA1	300015	R/W	Default 25% (2.5vdc)
Minimum output DA2\DA3	300016	R/W	Default 25% (2.5vdc)
Pre-heat temperature setting	300017	R/W	25-35, default: 28
0-10vdc signal input setting	300018	R/W	Default: 40% (4VDC) or (10.4mA)
Super low speed rpm	300019	R/W	0-10V, default:2VDC
Low speed rpm	300020	R/W	1-10VDC, default: 3VDC
Medium speed rpm	300021	R/W	1-10VDC, default: 6VDC
High speed rpm	300022	R/W	1-10VDC, default: 8.5VDC
Signal output setting	300023	R/W	1-10VDC (used to test, 0 = disable)
Temperature sampling time	300024	R/W	2-100, default: 5S
Factor of auto fan speed	300025	R/W	2-150, default:20
Factor of modulating valve	300026	R/W	2-250, default:150
Ti1 and Ti2 difference setting	300027	R/W	3-15, default:5
Ti3 and Ti4 difference setting	300028	R/W	3-15 default:10
Controller Hardware type setting	300029	R/W	0=air cleaner (S5) 1=FCU (S1/S2/S3, SWC-S) 2=FCU (S8) or (S8+W5) Default:2
Degree unit setting	300030	R/W	0=degree C 1=degree F
Temperature display setting	300031	R/W	0=Room temperature display on LED 1=Setting temperature display on LED
Setting temperature range	300032	R/W	0=setting temperature range is from 16-30 1=Setting temperature range is fixed. Cooling=24oC Heating=21oC
Temperature band setting	300033	R/W	1-9, default:1
Software type	300046	R/W	0=2-pipe with valve 1=4-pipe with std valve 2=4-pipe with 6-way valve

EH type	300047	R/W	0=without EH, 1=EH as booster; 2=EH as primary
DA1 control signal mode	300048	R/W	0=Tr/Ts 1=ESP
EC motor input ports	300049	R/W	0=CN4 working; 1=CN5 working 2=CN4+CN5 working default:0
PRO1 input type	300050	R/W	0=NO; 1=NC
Tr sensor setting	300051	R/W	0=sensor on the wired wall pad; 1=sensor on the main PCB; default:0
Reserved	300052	R/W	0-120, default:80
Reserved	300053	R/W	200-999 default:0;
E-heater	300054	R/W	unit:KW*10
Room temp. factor	300055	R/W	90-120, default:103
Water inlet temp. factor	300056	R/W	90-120, default:103
Delt T factor	300057	R/W	90-120, default:102
Product type	300058	R/W	00-99; default:00
Product model	300059	R/W	000-999; default:000
Ex-works data	300060	R/W	0000—9999
Software version	300061	R	10-99 default:10
Hardware version	300062	R	10-99 default:10
EC motor1 Low RPM setting	300063	R/W	200rpm-1500rpm default:500
EC motor1 Maxi RPM setting	300064	R/W	200rpm-1500rpm default:1200
EC motor2 Low RPM setting	300065	R/W	200rpm-1500rpm default:500
EC motor2 Maxi RPM setting	300066	R/W	200rpm-1500rpm default:1200
EC motor qty setting	300067	R/W	0=EC motor1 working 1=EC motor2 working 2=EC motor 1/2 working default:2
In auto mode, temp. Band setting	300068	R/W	1-15, default:5
Reserved	300069	R/W	
Reserved	300070	R/W	
Unit power input at High speed	300071	R/W	W*10
Unit power input at Med. speed	300072	R/W	W*10
Unit power input at Low speed	300073	R/W	W*10
Unit heat capacity at High speed	300074	R/W	KW*10
Unit heat capacity at Med. speed	300075	R/W	KW*10
Unit heat capacity at Low speed	300076	R/W	KW*10
Unit cool capacity at High speed	300077	R/W	KW*10
Unit cool capacity at Med. speed	300078	R/W	KW*10
Unit cool capacity at Low speed	300079	R/W	KW*10
DA2 control mode	300080	R/W	0=based on delta T; 1=based on water flow; 2=based on signal input2
DA2 Chilled water flow setting	300081	R/W	0-4000L/h; default: 1020
DA2/DA3 heating water flow setting	300082	R/W	0-4000L/h; default: 1020
DA3 control signal mode	300083	R/W	0=based on delta T; 1=based on water flow; 2=based on signal input3;
DA2 4-20mA input 2	300084	R/W	0-100, Default: 40%
DA2/DA3 4-20mA input 3	300085	R/W	0-100, Default: 40%

Input Register table:

Description	Address	Type*	Remark
Tr temperature sensor	400000	R	
Ti1 temperature sensor	400001	R	
Ti2 temperature sensor	400002	R	
Ti3 temperature sensor	400003	R	
Ti4 temperature sensor	400004	R	
Error code	400005	R	Bit0 = Room temperature sensor error Bit1 = Ti1 temperature sensor error Bit2 = Ti2 temperature sensor error Bit3 = Float switch error Bit4 = Indoor coil low temperature protection Bit5 = Indoor coil over-heat protection Bit6 = Filter switch Bit7 = Electrical heater failure Bit8 = Motor1 Error Bit9 = Motor2 Error Bit10 = System parameters error Bit11 = Anti-frozen error Bit12 = Ti3 temperature sensor error Bit13 = Ti4 temperature sensor error Bit14 = PM2.5 sensor Bit15 = AQI Error
Fan speed status	400006	R	Low = 04(H) Medium = 02(H) High = 01(H)
0-10VDC signal1	400007	R	
4-20mA signal2	400008	R	
EH	400009	R	0= disable, 1=booster, 2=primary
Unit type	400010	R	
DA1	400011	R	
DA2	400012	R	
DA3	400013	R	
Unit status	400017	R	Cooling mode = 01(H) Humidify mode = 02(H) Fan mode = 04(H) Heating mode = 08(H) Unit OFF=32(H)
Temperature in wall pad	400018	R	
Motor running time	400019	R	
Motor running terms	400020	R	0-100,
Cooling Capacity	400021	R	Unit: KWh
Cooling capacity terms	400022	R	0-100,
Heating capacity	400023	R	Unit: KWh
Heating capacity terms	400024	R	0-100,
EC motor1 actual RPM	400036	R	
EC motor2 actual RPM	400037	R	
EC motor1 error	400038	R	
EC motor2 error	400039	R	
Input signal ( 0-10Vdc)	400040	R	
Driver Temperature sensor	400041	R	
address	400042	R	
Reserved	400043	R	
water flow1	400044	R	m3/h
Water flow2	400045	R	m3/h
Cooling capacity	400046	R	
Heating capacity	400047	R	
4-20mA signal input3	400048	R	

\* R = read only, W = write only, R/W = read and write

## D.5. Modbus Network Setup for FCU group

### Network Setup

1. Disconnect the communication plug from the control box



2. Communication plug  
A, B, A, B is printed on the main PCB. When you connect the wires, please ensure connection of A to A and B to B.
3. Connection wire
  - 3.1. If the total length of wire is more than 1000m, please use shielded wire in order to protect the signal transmission.
  - 3.2. Complete wire connection

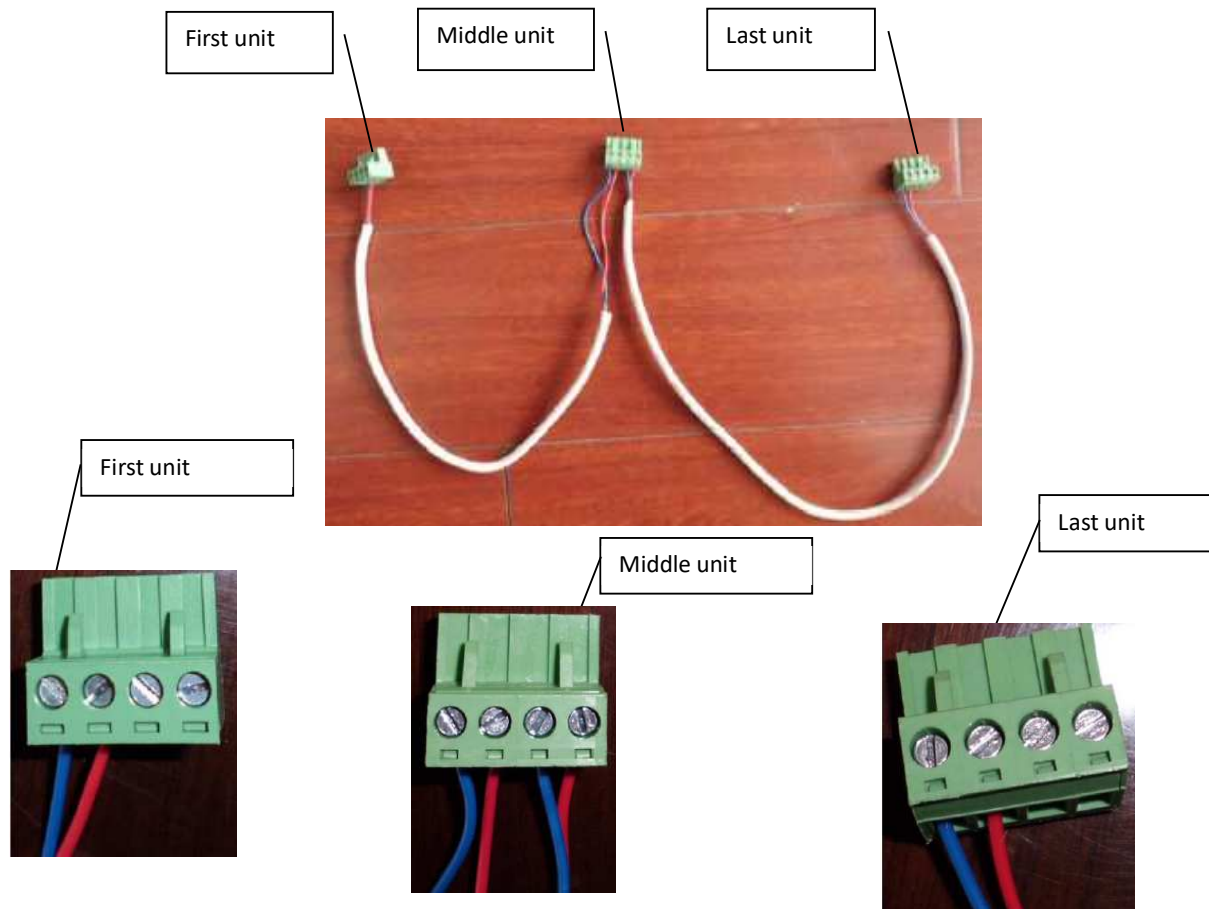

- 3.3. Wire connection check
  - 3.3.1. After the wire connection is completed, please check that the wire colours correspond.
  - 3.3.2. Check the wire contact by using a multimeter.

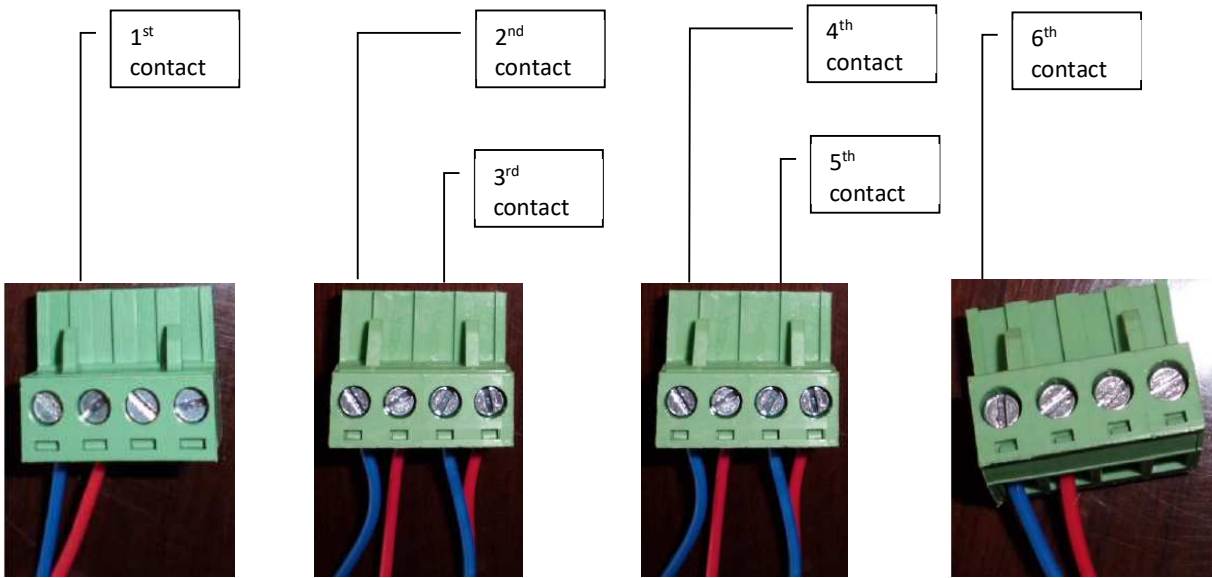

3.3.3. Check 1 and 2, 3 and 4, 5 and 6 to be sure connections are correct.

3.3.4. If the resistance between two wire contacts is too high, please check and reconnect the wire contacts.

4. Reconnect the communication plug to control box
5. Using wired wall pad or Modbus to set each unit address.

## D.6. LED Display and Error Description: I-Type (optional)

LED receiver in ABS housing with 0.5m or 1.8m pre-wiring



Complete Function PCB – I Type Control		
Fan speed setting	LED Display	Condition
High speed	Red LED On	Normal
Medium speed	Yellow LED On	Normal
Low speed	Green LED On	Normal

For all units - Green LED			
Error Description	Blink	Reason	Remedy
Return air sensor failure	Green LED blinks 1 times, stops for 3s	Room sensor unplugged or damaged.	1. Check if Tr plug is connected or not. 2. Check if sensor's resistance is correct or not.
Indoor coil sensor 1 failure	Green LED blinks 2 times, stops for 3s	Ti1 sensor unplugged or damaged.	1. Check if Ti1 plug is connected or not. 2. Check if sensor's resistance is correct or not.
Indoor coil sensor 2 failure	Green LED blinks 3 times, stops for 3s	Ti2 sensor unplugged or damaged.	1. Check if Ti2 plug is connected or not. 2. Check if sensor's resistance is correct or not.
Water pump failure	Green LED blinks 4 times, stops for 3s	Float switch is opened.	1. Check if the condensate water pipe is connected or not. 2. Check if the pump is functioning or not.
Indoor coil low temperature protection	Green LED blinks 5 times, stops for 3s	Water temperature is lower than 3 °C.	Check the water temperature.
Indoor coil over-heat protection	Green LED blinks 6 times, stops for 3s	Water temperature is higher than 70 °C.	Check the water temperature
Filter Switch (S8 PCB)	Green LED blinks 7 times, stops for 3s	Filter switch is opened.	1. Check if filter block or not 2. replace the new filter
Electric Heater failure	Green LED blinks 8 times, stops for 3s	Only for unit with EH. EH safety switch is opened.	1. Change fan speed to high. 2. Replace the damaged EH safety switch.
EC motor failure (CN4)	Green LED blinks 9 times, stops 3s	No EC motor feedback	1. Check Modbus setting. 2. Check the EC motor.
EC motor failure (CN5)	Green LED blinks 10 times, stops 3s	No EC motor feedback	1. Check Modbus setting. 2. Check the EC motor.
Anti-frozen protection	Green LED blinks 12 times, stops for 3s	When unit is standby, Tr<2°C.	1. Turn on unit to keep Tr high than 5°C



## E. Control Specifications: Flexible Function (W Type)

### E.1. I/O Port Definitions for W type

I/O Port Definitions For W

I/O		Code	
Voltage input	Phase	L1	External 230VAC power supply connection to the PCB
	Neutral	N1	
	Earth	GND	
Signal Input	Modulating signal1	+/-	Low voltage modulating signal input (0-10Vdc)
Voltage output	DC motor 1	U, V, W	3-wire connection for DC motor1
	DC motor 2	U1, V1, W1	3-wire connection for DC motor2 only for W5
Communication port	Modbus Port	A, B	Modbus Protocol

## E.2. Wiring Diagrams for W type

Flexible Function PCB W4 for HAHU-200~400-EC

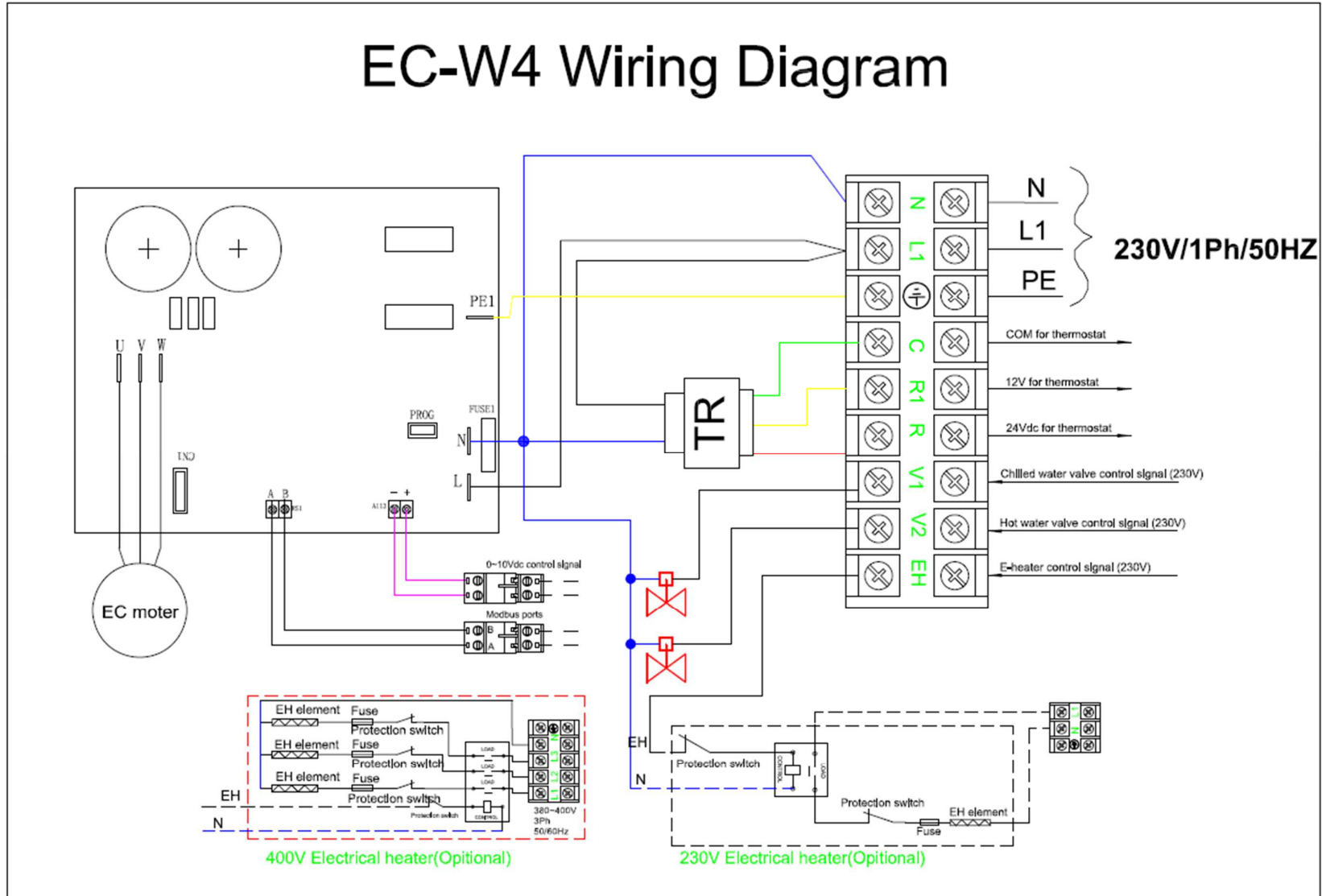

Flexible Function PCB: EC-W5 for HAHU-600~800-EC

# EC-W5 Wiring Diagram

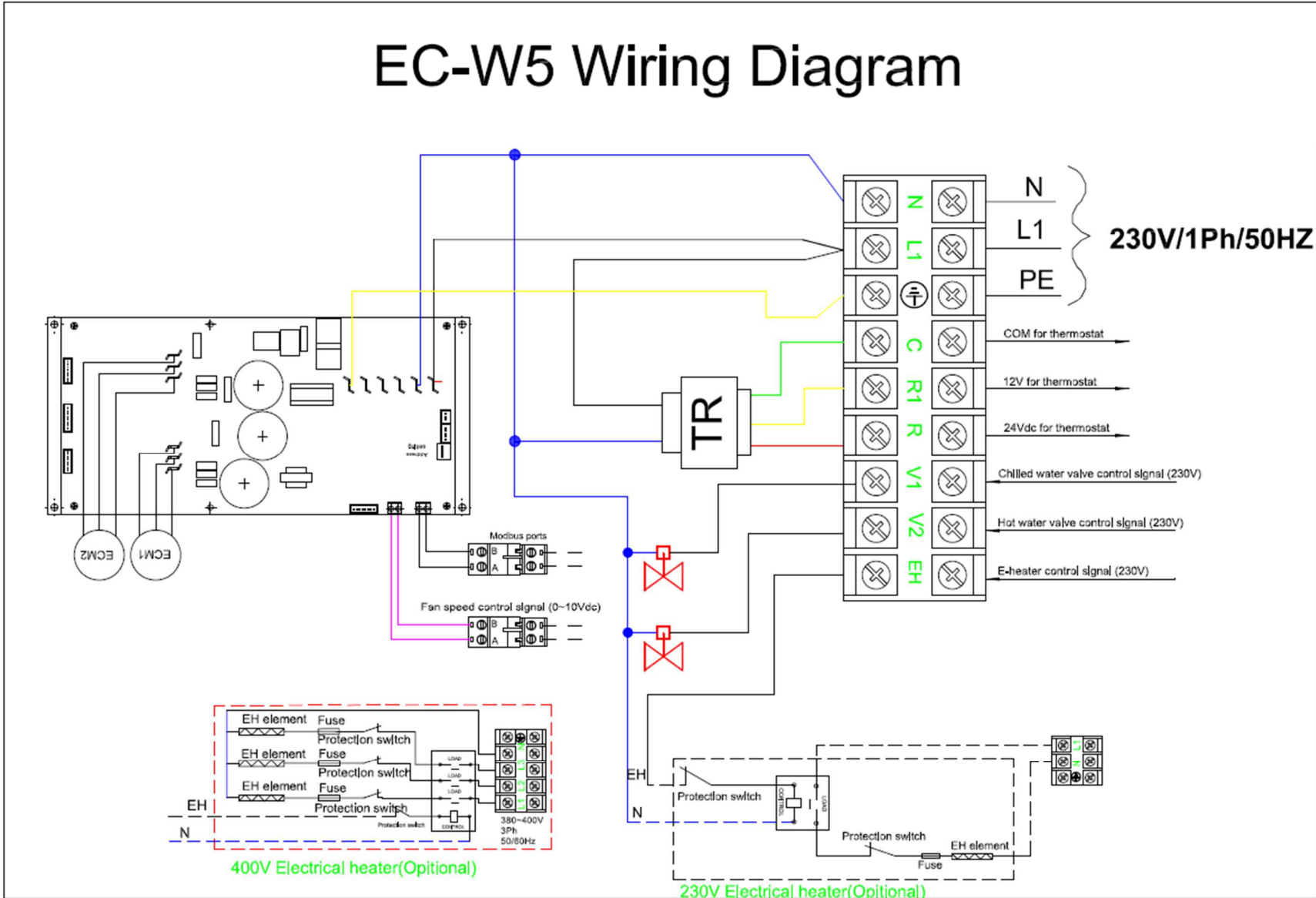

PG2021 Global HAHU-VP-ECM-005

## E.3. Control Logic Specifications

### E.3.1. Control Logic Specifications for W4/W5

The unit is turned ON when modulating signal input is more than 2.0VDC or Modbus 300006 and 300007 settings;

The unit is turned OFF when modulating signal input is less than 2.0VDC and Modbus 300006 and 300007 settings.

## E.4. Open Modbus Protocol

### E.4.1. Open Modbus Protocol (For EC-W4/W5 PCB)

Transfer Mode: RTU, BAUD Rate: 9600bps, 8 data bit, 1 stop bit, None parity bit

The communications require a delay between reading an answer and sending the next command of 80ms. All temperature is equal to reading data\*10 accuracy: 0.1 degree C.

#### Holding Register table:

Description	Address	Type*	Remark
EC1 Minimum RPM	300001	R/W	200rpm-1500rpm
EC1 Maximum RPM	300002	R/W	200rpm-1500rpm
EC2 Minimum RPM	300003	R/W	200rpm-1500rpm
EC2 Maximum RPM	300004	R/W	200rpm-1500rpm
Motor qty setting	30004	R/W	0=EC motor1 working 1=EC motor2 working 2=EC motor 1/2 working W4-only set 0; W5/W6 default:=2
Signal inputs setting for W6	30005	R/W	0=Signal input 1 works; Motor 1/2 works based on signal input1. 1=Signal input2 works; Motor 1 works based on signal input1. Motor 2 works based on signal input2. Default:0
Motor1 RPM writing	30006	R/W	MS30006=0-200, Motor1 works according to signal input1; MS30006=above 200, Motor1 RPM is according to RPM writing.
Motor2 RPM writing	30007	R/W	MS30007=0-200, Motor2 works according to signal input2; MS30007=above 200, Motor2 RPM is according to RPM writing.
Unit Address setting	30008	R	1-15; Set by Dip-switch Default: 55

#### Input Register table:

Description	Address	Type*	Remark
EC motor1 actual RPM	40000	R	
EC motor2 actual RPM	40001	R	
EC motor1 error	40002	R	
EC motor2 error	40003	R	
Input signal1 ( 0-10Vdc)	40004	R	
Input signal2 ( 0-10Vdc)	40005	R	
Software Version	40017	R	

\* R = read only, W = write only, R/W = read and write

## F. User Interface

### F.1. Remote Handset for I-control

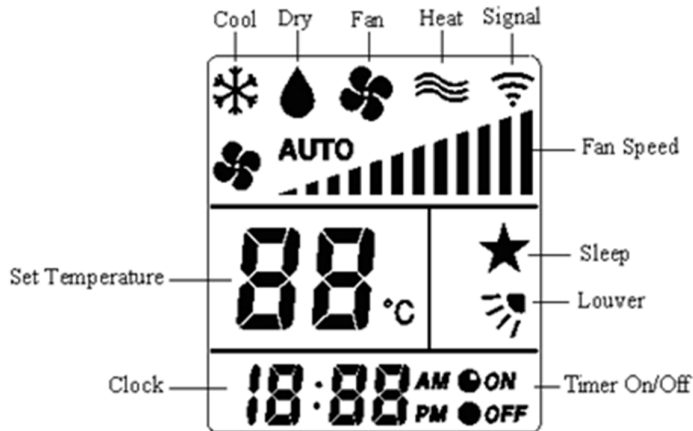
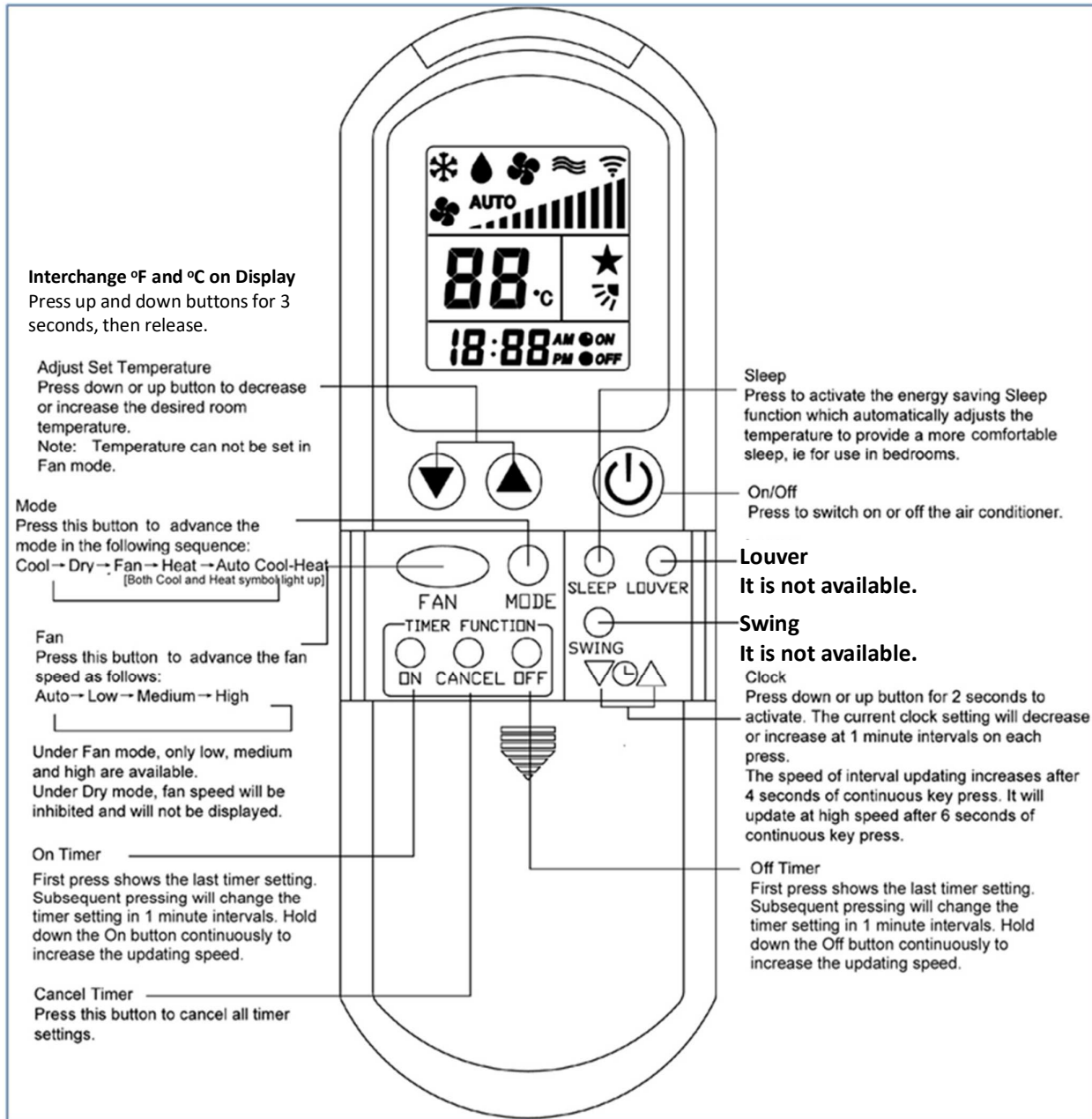

**Attention:**

When unit with handset is master, settings are automatically sent to slaves;  
Auto Cool-Heat operation will be applicable in 4-pipe system only.  
Use "Swing" and "Louver" are not applicable.  
\*European version only uses degree C setting.



























## F.2. Wired Wall Pad Controller for I-Control



### F.2.1. LED display

Code	Legend	Code	Legend	Code	Legend
S1	Monday	S14	Heating Mode	S27	Fahrenheit degree
S2	Tuesday	S15	Ventilation Mode	S28	Celsius degree
S3	Wednesday	S16	Auto Mode	S29	Fan
S4	Thursday	S17	Sleep mode	S30	0-Auto; 1-Low;2-Medium; 3-High
S5	Friday	S18	Swing mode	S31	Unit address
S6	Saturday	S19	LED lock	S32	Unit No. / Error code
S7	Sunday	S20	Setting Temperature	S33	Weekly timer
S8	Timer-ON	S21	Room Temperature	S34	C-cooling
S9	Timer-ON time Normally: Real time	S22	RH (if need)	S35	H-heating
S10	Timer-OFF	S23	CO2 density (if need)	S36	Energy consumption
S11	Timer-OFF time	S24	PM2.5 density (if need)	S37	Energy consumption cycle
S12	Cooling Mode	S25	Data Display		
S13	Dehumidification	S26	RH percentage		
S38	On/Off Button	S40	Fan speed setting	S42	Up
S39	Mode setting	S41	Parameter setting	S43	Down

F.2.2. Operation guide

S38	On/OFF Button	Press  to turn on. Press it again to turn off.
S39	Mode button	With wall pad on, p  to select Cooling, Dehumidification, Heating, Ventilation or Auto sequentially.or Auto sequentially.
S40	Fan Speed Button	Press  to change from 0 to3. 0=Auto speed, 1=Low speed, 2=Medium speed, 3=High speed.
S41	Parameter Setting Button	Long press  for 5 seconds to set today's day of week. Press  or  to change from Monday to Sunday.
		Long press  for 5 seconds then short press it once to set current time. Press  or  to change current time.
		Long press  for 5 seconds then short press it twice to set Timer ON. Press  to set day of week from Monday to Sunday. Press  or  to change Timer ON time. Press  to turn Timer ON on or off and S8 appears or disappears.
		Long press  for 5 seconds then short press it 3 times to set Timer OFF time. Press  to set day of week from Monday to Sunday. Press  or  to change Timer OFF time. Press  to turn Timer OFF on or off and S10 appears or disappears.
		Long press  for 5 seconds then short press it 4 times to set group control and U31 appears. The function is reserved.
		Long press  for 5 seconds then short press it 5 times to set unit address and U32 appears. Press  or  to change unit address.
		<p>*** For MODBUS user only</p> <p>Long press  for 5 seconds then short press it 6 times to set unit parameters. Press  to change the parameter type. Press  or  to change parameter setting value.</p> <p>S31/S32 displays "U001", which is used to set unit type.          0=iAIR ..... Mode: Ventilation T,RH, CO2, PM2.5 are displayed.          1=iFCU ..... Mode: S12, S13, S14, S15, S16, S21 or S20 is displayed.          2=iAHU ..... Mode: S12, S13, S14, S15, S16, S21 or S20 is displayed.          3=iAHU with air cleaner ..... Mode: S12, S13, S14, S15, S16, T, RH, CO2, PM2.5 are displayed.</p> <p>S31/S32 displays "U002", which is used to set unit of temperature degree.          0=Celsius degree.</p>

1=Fahrenheit degree.

S31/S32 displays "U003", which is used to select display temperature on LCD.

1=Setting temperature.

0=Room temperature.

S31/S32 displays "U004", which is used to set setting temperature range.

0=Setting temperature is from 16~30°C.

1=Cooling setting temperature 24°C, Heating setting temperature 21°C.

S31/S32 displays "U005", which is used to set setting temperature band.

1~9°C.

S31/S32 displays "U006-U009", which are reserved to set parameters with optional accessory to measure PM2.5 and CO2 values.

S31/S32 displays "U010~U011", which are reserved.

S31/S32 displays "U012", which is used to set setting RH point.

30~70, default: 50

S31/S32 displays "U013", which is used to set setting RH band.

10~30, default: 10

S31/S32 displays "U014", which is used to set unit address.

1~255, default: 1

S31/S32 displays "U015", which is used to set unit ESP.

0~100%, default: 40%

S31/S32 displays "U016", which is reserved.

S31/S32 displays "U017", which is used to set software. (please refer to different PCB)

0=2-pipe with valve

1=2-pipe without valve

2=4-pipe with std valve

3=4-pipe with 6-way

valve

S31/S32 displays "U018", which is reserved.

S31/S32 displays "U019", which is used to set DA1 function

When U001=2,3

U019=0, fan control signal is based on Tr, Ts PID calculation

U019=1, fan control signal is based on ESP PID calculation

S31/S32 displays "U020", which is used to calibrate the sensor on the wired wall pad.

-5~5, default: -3

S31/S32 displays "U021", which is used to set EH function

U021= 0, without EH.

U021= 1, EH as booster.

U021=2, EH as primary.







S31/S32 displays "U022", which is used to select Tr sensor.

0=the sensor in the WWP.

1=the sensor in the PCB.

S31/S32 displays "U023", which is used to display cooling and heating energy consumption.



		<p>0=S34/S35/S36/S37 disappears          1=S34/S35/S36/S37 appears          In cooling and dehumidification mode, cooling energy consumption is shown.          In heating mode, heating energy consumption is shown.          2=Motor running time is shown.</p> <p>S31/S32 displays “U024”, which is used to set low speed RPM or control signal.</p> <p>S31/S32 displays “U025”, which is used to set medium speed RPM or control signal.</p> <p>S31/S32 displays “U026”, which is used to set high speed RPM or control signal.</p> <p>S31/S32 displays “U027”, which is used to set Delta T OF Ti1/Ti2.</p> <p>S31/S32 displays “U028”, which is used to set Delta T OF Ti3/Ti4.</p> <p>S31/S32 displays “U029”, which is used to read unit type.</p> <p>S31/S32 displays “U030”, which is used to read unit model.</p> <p>S31/S32 displays “U031”, which is used to read unit manufacturing date.</p>
S32	Error code	<p>S32 : E** blinks</p> <p>Bit0 = Room temperature sensor error          Bit1 = Ti1 temperature sensor error          Bit2 = Ti2 temperature sensor error          Bit3 = Float switch error          Bit4 = Indoor coil low temperature protection          Bit5 = Indoor coil overheat protection          Bit6 =Filter switch          Bit7 = Electrical heater failure          Bit8 = Motor1 Error          Bit9 =Motor2 Error          Bit10 = System parameters error          Bit11 = Anti-frozen error          Bit12 = Ti3 temperature sensor error          Bit13 = Ti4 temperature sensor error          Bit14 =PM2.5 sensor error          Bit15 =AQI Error</p>
Combination Button Function		<p>Screen Lock Function</p> <p>Long press  for 5 seconds, S19 appears and screen is locked.</p> <p>Long press  for 5 seconds again, S19 disappears and screen is unlocked.</p> <hr/> <p>Swings Function</p> <p>Long press  for 5 seconds, S18 appears and swings is ON.</p> <p>Long press  for 5 seconds again, S18 disappears and swings is OFF.</p> <hr/> <p>Sleep Mode</p> <p>Long press  for 5 seconds, S17 appears and sleep mode is ON.</p> <p>Long press  for 5 seconds again, S17 disappears and sleep mode is OFF.</p>

## F.2.3. Error Code List

Error Description	Code	Reason	Remedy
Room temperature sensor error	E1	Room sensor unplugged or damaged.	1. Check if Tr plug is connected or not. 2. Check if sensor's resistance is correct or not.
Indoor coil sensor 1 failure	E2	Ti1 sensor unplugged or damaged.	1. Check if Ti1 plug is connected or not. 2. Check if sensor's resistance is correct or not.
Indoor coil sensor 2 failure	E3	Ti2 sensor unplugged or damaged.	1. Check if Ti2 plug is connected or not. 2. Check if sensor's resistance is correct or not.
Float switch error	E4	Float switch is opened.	1. Check if the condensate water pipe is connected or not. 2. Check if the pump is functioning or not.
Indoor coil low temperature protection	E5	Water temperature is lower than 3 °C.	Check the water temperature.
Indoor coil over-heat protection	E6	Water temperature is higher than 70 °C.	Check the water temperature
Filter switch protection	E7	Filter Switch is open.	Replace or clean filter.
Electric Heater failure	E8	Only for unit with EH.	1. Change fan speed to high.
		EH safety switch is opened.	2. Replace the damaged EH safety switch.
EC motor failure(CN4)	E9	No EC motor feedback	1. Check Modbus setting. 2. Check the EC motor.
EC motor failure(CN5)	E10	No EC motor feedback	1. Check Modbus setting. 2. Check the EC motor.
Motor qty setting error (S6 PCB)	E11	Motor Qty setting error	1: check Modbus setting
Anti-frozen protection	E12	When unit is standby, Tr<2°C.	1. Turn on unit to keep Tr high than 5°C
Indoor coil sensor 3 failure (S6 PCB)	E13	Ti3 sensor unplugged or damaged.	1. Check if Ti3 plug is connected or not. 2. Check if sensor's resistance is correct or not.
Indoor coil sensor 4 failure (S6 PCB)	E14	Ti4 sensor unplugged or damaged.	1. Check if Ti4 plug is connected or not. 2. Check if sensor's resistance is correct or not.
PM2.5 sensor failure (S6 PCB)	E15	PM2.5 sensor unplugged or damaged.	1. Check if PM2.5 plug is connected or not. 2. Check if sensor's resistance is correct or not.
AQI sensor failure (S6 PCB)	E16	AQI sensor unplugged or damaged.	1. Check if AQI plug is connected or not. 2. Check if sensor's resistance is correct or not.
Wired Wall Pad failure	E17	WWP unplugged or not well	Check plugs

## F.2.4. Dimensions and installation

### Dimensions

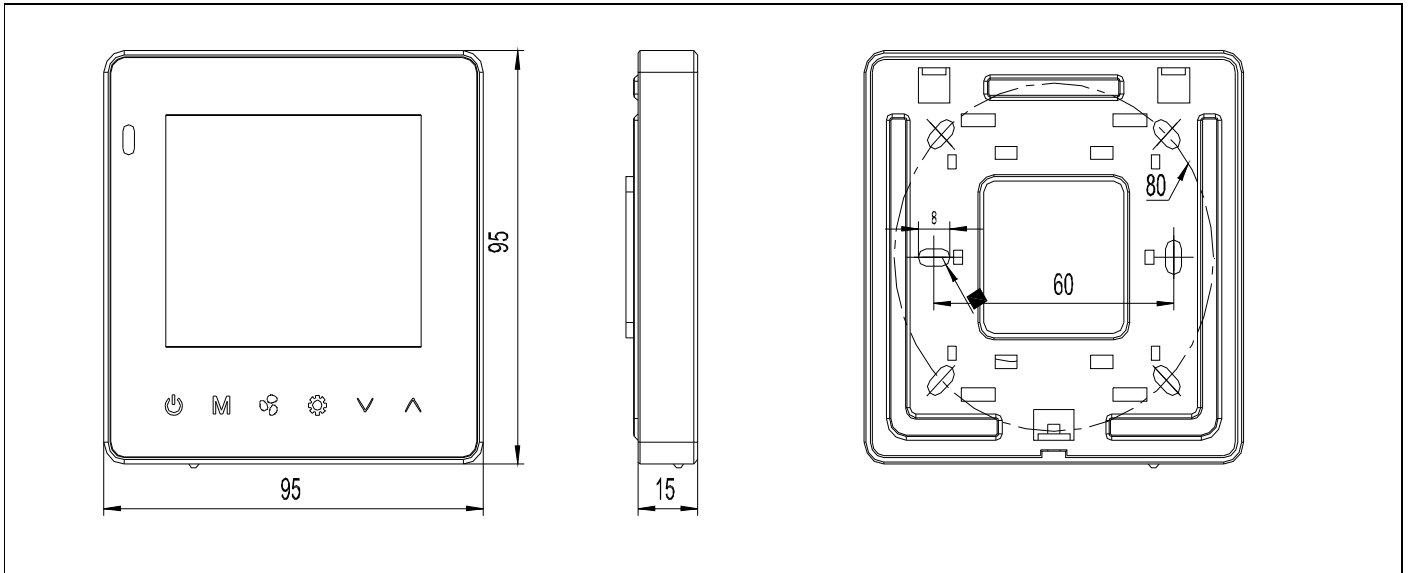

### Installation

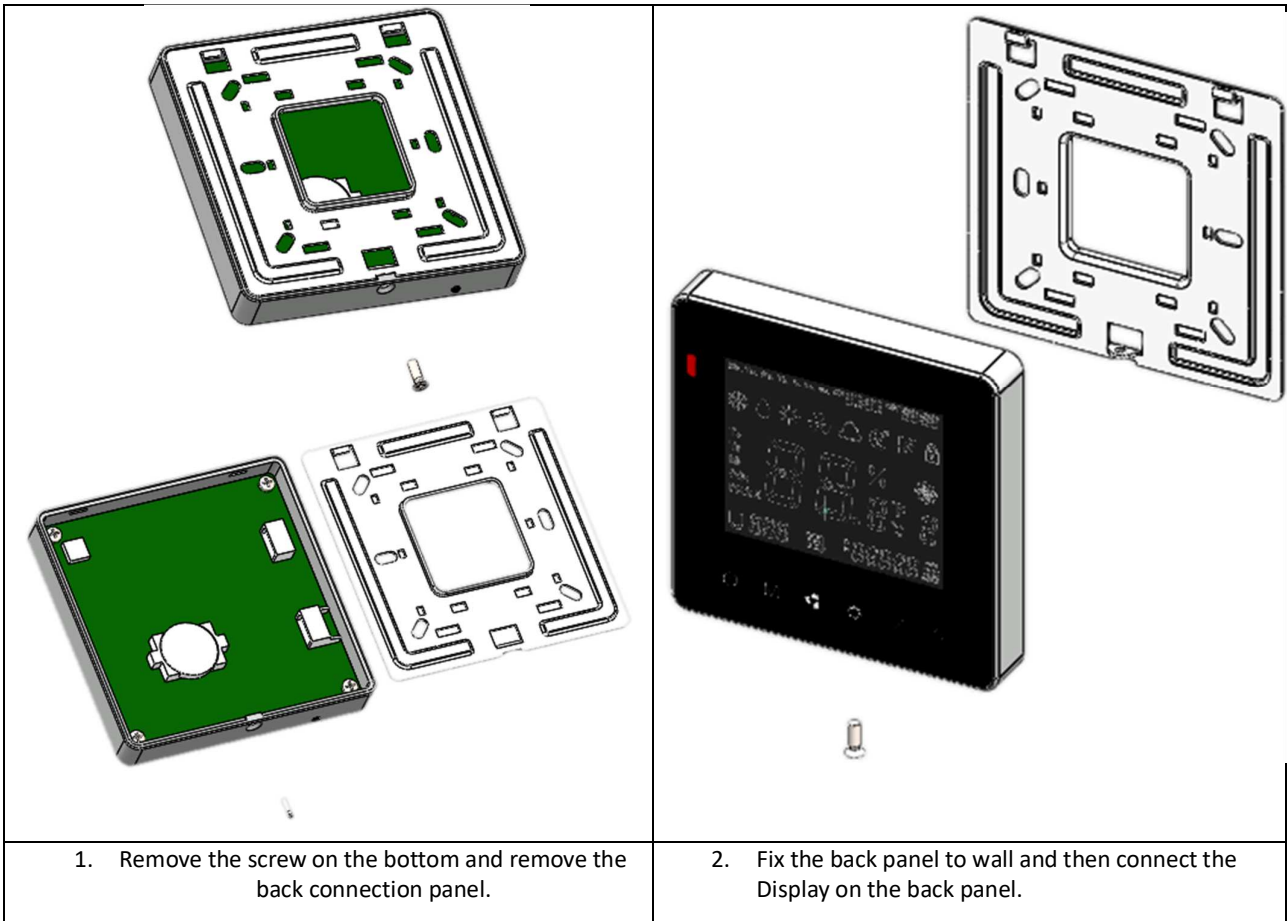

## G. Sensor Resistance R-T Conversion Table

Resistance: R (25°C) = 10KΩ ± 1%      Beta Constant: B (25/85) = 3950 ± 1%

Temp. (deg. C)	Rmax (k Ohms)	Rnor (k Ohms)	Rmin (k Ohms)	Temp. (deg. C)	Rmax (k Ohms)	Rnor (k Ohms)	Rmin (k Ohms)
-30	186.3613	179.2666	172.4247	5	25.9521	25.4562	24.9672
-29	174.9608	168.4053	162.0793	6	24.6872	24.2274	23.7738
-28	164.3317	158.2726	152.4218	7	23.4912	23.0650	22.6443
-27	154.4170	148.8151	143.4022	8	22.3599	21.9650	21.5750
-26	145.1643	139.9837	134.9746	9	21.2897	20.9239	20.5622
-25	136.5254	131.7332	127.0964	10	20.2768	19.9380	19.6028
-24	128.4558	124.0216	119.7285	11	19.3178	19.0041	18.6937
-23	120.9146	116.8107	112.8348	12	18.4096	18.1193	17.8318
-22	113.8640	110.0648	106.3818	13	17.5493	17.2807	17.0146
-21	107.2691	103.7512	100.3387	14	16.7340	16.4857	16.2394
-20	101.0977	97.8396	94.6771	15	15.9612	15.7317	15.5040
-19	95.3201	92.3020	89.3705	16	15.2284	15.0164	14.8059
-18	89.9088	87.1124	84.3946	17	14.5333	14.3376	14.1432
-17	84.8385	82.2471	79.7268	18	13.8738	13.6933	13.5139
-16	80.0856	77.6837	75.3463	19	13.2479	13.0816	12.9160
-15	75.6284	73.4018	71.2336	20	12.6537	12.5005	12.3479
-14	71.4468	69.3823	67.3708	21	12.0895	11.9485	11.8080
-13	67.5220	65.6077	63.7412	22	11.5535	11.4239	11.2946
-12	63.8370	62.0616	60.3295	23	11.0442	10.9252	10.8064
-11	60.3755	58.7288	57.1212	24	10.5602	10.4510	10.3419
-10	57.1228	55.5953	54.1032	25	10.1000	10.0000	9.9000
-9	54.0651	52.6480	51.2629	26	9.6709	9.5709	9.4710
-8	51.1895	49.8747	48.5889	27	9.2623	9.1626	9.0630
-7	48.4842	47.2643	46.0705	28	8.8732	8.7738	8.6747
-6	45.9381	44.8062	43.6978	29	8.5025	8.4037	8.3052
-5	43.5409	42.4906	41.4615	30	8.1494	8.0512	7.9534
-4	41.2831	40.3086	39.3531	31	7.8128	7.7154	7.6184
-3	39.1559	38.2516	37.3644	32	7.4919	7.3953	7.2993
-2	37.1508	36.3117	35.4880	33	7.1859	7.0903	6.9953
-1	35.2603	34.4817	33.7169	34	6.8940	6.7995	6.7056
0	33.4771	32.7547	32.0447	35	6.6156	6.5221	6.4294
1	31.7945	31.1243	30.4652	36	6.3498	6.2576	6.1660
2	30.2064	29.5847	28.9728	37	6.0962	6.0051	5.9148
3	28.7068	28.1301	27.5623	38	5.8540	5.7642	5.6752
4	27.2904	26.7556	26.2286	39	5.6227	5.5342	5.4465

Temp. (deg. C)	Rmax (k Ohms)	Rnor (k Ohms)	Rmin (k Ohms)	Temp. (deg. C)	Rmax (k Ohms)	Rnor (k Ohms)	Rmin (k Ohms)
40	5.4018	5.3146	5.2283	77	1.4137	1.3722	1.3317
41	5.1907	5.1049	5.0199	78	1.3681	1.3275	1.2880
42	4.9890	4.9045	4.8210	79	1.3243	1.2845	1.2458
43	4.7961	4.7130	4.6309	80	1.2820	1.2431	1.2053
44	4.6117	4.5300	4.4494	81	1.2413	1.2033	1.1663
45	4.4354	4.3551	4.2759	82	1.2021	1.1649	1.1287
46	4.2667	4.1878	4.1100	83	1.1644	1.1279	1.0926
47	4.1053	4.0278	3.9515	84	1.1279	1.0923	1.0577
48	3.9508	3.8748	3.7999	85	1.0928	1.0580	1.0241
49	3.8030	3.7283	3.6548	86	1.0590	1.0249	0.9918
50	3.6614	3.5882	3.5161	87	1.0264	0.9930	0.9606
51	3.5258	3.4540	3.3833	88	0.9949	0.9623	0.9306
52	3.3960	3.3255	3.2562	89	0.9646	0.9326	0.9016
53	3.2715	3.2025	3.1346	90	0.9353	0.9040	0.8737
54	3.1523	3.0846	3.0181	91	0.9070	0.8764	0.8468
55	3.0380	2.9717	2.9065	92	0.8797	0.8498	0.8208
56	2.9285	2.8635	2.7996	93	0.8534	0.8241	0.7958
57	2.8234	2.7597	2.6972	94	0.8280	0.7994	0.7716
58	2.7227	2.6603	2.5990	95	0.8035	0.7754	0.7483
59	2.6260	2.5649	2.5049	96	0.7798	0.7523	0.7258
60	2.5333	2.4734	2.4147	97	0.7569	0.7300	0.7041
61	2.4443	2.3856	2.3282	98	0.7348	0.7085	0.6831
62	2.3589	2.3014	2.2452	99	0.7134	0.6877	0.6628
63	2.2768	2.2206	2.1656	100	0.6928	0.6676	0.6433
64	2.1981	2.1431	2.0892	101	0.6728	0.6482	0.6244
65	2.1224	2.0686	2.0159	102	0.6536	0.6295	0.6062
66	2.0498	1.9970	1.9455	103	0.6349	0.6113	0.5885
67	1.9800	1.9283	1.8779	104	0.6169	0.5938	0.5715
68	1.9129	1.8623	1.8130	105	0.5995	0.5769	0.5550
69	1.8484	1.7989	1.7507	106	0.5826	0.5605	0.5391
70	1.7864	1.7380	1.6908	107	0.5663	0.5447	0.5237
71	1.7267	1.6794	1.6332	108	0.5506	0.5293	0.5089
72	1.6694	1.6231	1.5779	109	0.5353	0.5145	0.4945
73	1.6142	1.5689	1.5247	110	0.5206	0.5002	0.4806
74	1.5612	1.5168	1.4736	111	0.5063	0.4863	0.4671
75	1.5101	1.4667	1.4245	112	0.4924	0.4729	0.4541
76	1.4610	1.4185	1.3772	113	0.4791	0.4599	0.4415

## H. Troubleshooting

Symptoms	Cause	Remedy
The fan coil does not start up	No voltage	Check for presence of voltage Check fuse on board
	Mains switch in the "OFF" position	Place in the "ON" position
	Faulty room control	Check the room control
	Faulty fan	Check fan motor
Insufficient output	Filter clogged	Clean the filter
	Air flow obstructed	Remove obstacles
	Room control regulation	Check the room air sensor
	Incorrect water temperature	Check the water source
Noise and vibrations	Air present	Check the air vent
	Contact between metal parts	Check for loosening parts
	Loose screws	Tighten screws



Note: All the information or data in this manual may be changed without notice.

#### EUROPE

C / Rio Jucar, Nave 6 P.I El Saladar  
Lorquí; Murcia, Spain 30564  
Ph: (+34) 968 046 262

#### ASIA

6 On Ping St, R.6 - Block A, 9th Floor,  
New Trade Plaza, Shatin, Hong Kong  
Ph: (+852) 2648 8887

[www.pghvac.com](http://www.pghvac.com)

[contact@pghvac.com](mailto:contact@pghvac.com)