INSTALLATION, OPERATION & SERVICE MANUAL

DOUBLE SKIN MEDIUM STATIC DUCTED PDWD-EC



INVESTING IN QUALITY, RELIABILITY & PERFORMANCE

ISO 9001 QUALITY



Management Service

Every product is manufactured to meet the stringent requirements of the internationally recognized ISO 9001 standard for quality assurance in design, development and production.

World Leading Design and Technology

Equipped with the latest air-conditioning test rooms and manufacturing technology, we produce over 50,000 fan coil units each year, all conforming to the highest international standards of quality and safety.

CE SAFETY STANDARDS



Product Service

All products conform to the Certificate Europe directives (Machinery Safety, Electromagnetic Compatibility and Low Voltage), as required throughout the European Community, to guarantee correct standards of safety.

The Highest Standards of Manufacturing

In order to guarantee the very highest standards and performance, we manage every stage in the manufacturing of our products. Throughout the production process we maintain strict control, starting with our extensive resources in research and development through to the design and manufacture of almost every individual component, from molded plastics to the assembly of units and controllers.

WEEE MARK



All products conform to the "WEEE" directive to guarantee correct standards of environmental solutions.

Quality Controlled from Start to Finish

Our highly trained staff and strict quality control methods enable us to produce products with an exceptional reputation for reliability and efficiency, maintained over many years. As well as CE certification and ISO 9001, several products ranges have UL / ETL safety approval in the USA and Canada, Eurovent performance and sound certification as well as ROHS compliance for Europe, giving you the confidence of knowing our company is the right choice when selecting fan coil units.

ALWAYS MAKE SURE THIS MANUAL REMAINS WITH THE UNIT. READ THIS MANUAL BEFORE PERFORMING ANY OPERATION ON THE UNIT.

Table of Contents

A. Technical Data	3
A.1. General Description	3
A.2. General Specifications.....	4
A.2.1. 2-pipe Systems.....	4
A.2.2. 4-pipe Systems.....	7
A.3. Sound Data.....	9
A.4. Coil Data.....	14
A.5. Dimension Drawings.....	15
B. Installation.....	18
B.1. Safety Precautions	18
B.2. Location.....	19
B.3. Installation Procedures.....	19
B.4. Insulation	21
B.5. Air Duct Connection	21
B.6. Service Connection.....	21
B.7. Unit Operation.....	21
C. Maintenance.....	22
C.1. General Maintenance.....	22
C.2. Regular Maintenance.....	22
C.3. Filter Cleaning.....	22
C.4. Coil and Fan Motor Assembly Maintenance.....	23
C.5. EH Installation and Maintenance.....	23
D. Control Specifications: Intelligent Control (I TYPE).....	24
D.1. I/O Port Definitions for I TYPE.....	24
D.2. Wiring Diagram for I Type.....	25
D.3. Control Logic for I control.....	28
D.3.1. Control Logics for I Control for EC-S3 (300029=1).....	28
D.3.2. Control Logics for I Control for EC-S8 (300029=2).....	32
D.4. Open Modbus Protocol for I-control	38
D.4.1. Open Modbus Protocol for EC-S3	38
D.4.2. Open Modbus Protocol For EC-S8.....	42
D.5. Modbus Network Setup for FCU group	46
D.6. LED Indication and Error Description: I-Type (optional)	48
E. Control Specifications: Flexible Function (W TYPE).....	49
E.1. I/O Port Definitions for W type	49
E.1.1. I/O Port Definitions for W3	49
E.1.2. I/O Port Definitions for EC-W4/W5	49
E.2. Wiring Diagram for W Type.....	50
E.3. Control Logic Specification for W Control.....	53
E.3.1. Control Logic Specification for W3 Control	53
E.3.2. Control Logic Specification for W4/5 Control.....	53
E.4. Open Modbus Protocol.....	54
E.4.1. Open Modbus Protocol for W3	54
E.4.2. Open Modbus Protocol for W4/W5	55
F. User Interface.....	56
F.1. Remote Handset for I Type Control.....	56
F.2. Wired Wall Pad Controller for I-Control	57
F.2.1. LED display	57
F.2.2. Operation guide.....	58
F.2.3. Error Code List	61
F.2.4. Dimensions and installation	62
G. Sensor Resistance R-T Conversion Table	63
H. Troubleshooting	64

MODEL CODE NOMENCLATURE

<u>1</u>	2	<u>3</u>	4	5	6	7
<u>PDWD</u>	<u>-3R</u>	<u>-400</u>	<u>-V</u>	<u>I</u>	<u>-EC</u>	<u>-RS</u>

Notation		Description
1	PDWD	Intelligent Air Handling Double Skins
2	3R	3R: 2-pipe 3-row 4R: 2-pipe 4-row 3R+1: 4-pipe 3-row for cooling and 1 row for heating
3	400	Unit Size (See General Specification Section A for cooling and heating capacities.)
4	V	V – 2 pipe system P – 4 pipe system
5	I	Control type: I – Intelligent Control W – Flexible function Control
6	EC	EC Motor
7	RS	Connection type: RS – Right LS – Left

A. Technical Data

A.1. General Description

STRUCTURE

Casing is double skin with inner wall and outer wall coated steel panels in RAL 9010 colour with high pressure PU foam insulation sandwiched in between. The unit contains a gravity drain pan inside the casing with 3/4" outlet for drain pipe connection. The unit has a bottom access panel, providing easy access to fans, motors and filters.

COILS

Constructed with seamless copper tubes and headers. The tubes are mechanically expanded into corrugated aluminum fin material for a permanent primary to secondary surface bond. Coils are tested at 35 bar (500 PSI) and recommended for operation at 20 bar (300 PSI). Coils include manual air vent and water purge valves.

FAN WHEELS

Housing is a double-inlet forward curved centrifugal type. Wheels are statically and dynamically balanced for smooth, quiet operation. The housing is constructed from heavy gauge galvanized steel with die-formed inlet cones.

EC MOTOR

The unit adopts EC motor powered by PCB, the constant torque, permanent magnet brushless EC motor with preliminary 3-speed setting allows precise air balancing.

FILTER

It is easily removable and washable and is made from self-extinguishing acrylic with an efficiency of class EU2 (G2) (Merv 2-4).

CONTROL SYSTEMS

1. Intelligent control (I type)

Intelligent control board is controlled via Infra-red handset and/or Intelligent wired wall pad, is field programmable and easy to be configured through the wired wall pad or open Modbus protocol with VV and VAV control logics, provides variable speed indoor fan control, integrates with Intelligent modulating valves to allow Auto Dynamic Balancing and Intelligent Constant Delta T management systems. It controls 2-pipe, 2-pipe with electric heater, 2-pipe with 6-way valve and 4-pipe systems.

2. Flexible control (W type)

This control options features flexible functionality for external thermostat applications, allowing the independent control of drain pumps(if equipped), offering zone control product operations, and limited LED diagnostics. In products where louvers are required, this control allows the stepping motors to open the louver at maximum position or close them when power of the unit is OFF.

A.2. General Specifications

A.2.1. 2-pipe Systems

Product range: PDWD-3R-V-EC 3-row coil 2-pipe with EC motor(s)

PDWD-3R-[Size]-V-EC				400	800	1200	1600	2000	
Unit Configuration	Configuration			2-pipe					
	Number Of Fan Blowers			Single	Twin			Four	
	Power Supply		V/Ph/Hz	220~240 / 1 / 50~60					
Performance Data	Air	Air Flow	H	m3/hr	691	1429	2322	2694	5389
			M		445	1230	1795	2047	4094
			L		402	741	1249	1650	3300
		ESP	H	Pa	120	120	120	120	120
			M		120	120	120	120	120
			L		50	50	50	50	50
	Cooling	Total Cooling Capacity	H	kW	3.74	7.2	11.02	13.04	23.22
			M		2.64	6.4	9.06	10.45	18.88
			L		2.43	4.31	6.78	8.83	16.03
		Sensible Cooling Capacity	H		2.64	5.15	7.93	9.31	17
			M		1.83	4.53	6.41	7.4	13.68
			L		1.68	2.98	4.74	6.18	11.46
	Heating	Heating Capacity	H	kW	3.78	7.39	11.36	13.56	24.13
			M		2.67	6.57	9.34	10.87	19.62
			L		2.46	4.43	6.99	9.19	16.66
		Max. Electric Heater Capacity				3	3	6	9
	Sound	Sound Pressure Level (Outlet)		dB(A)	56/53/43	58/56/47	56/52/45	60/58/50	65/63/60
		Sound Pressure Level (Inlet + Radiated)			59/56/46	61/59/50	57/55/48	63/61/53	65/63/60
		Sound Power Level (Outlet)			65/62/52	67/65/56	65/61/54	69/67/59	74/72/69
		Sound Power Level (Inlet + Radiated)			68/65/55	70/68/59	68/64/57	72/70/62	74/72/69
	Electrical	Fan Motor Power	H	W	202	281	310	477	672
			M		121	208	151	304	546
			L		34	65	70	108	280
	Fan Motor Running Current @ H		A	1.76	2.44	2.7	4.15	5.84	
	Hydraulic	Cooling Water Flow Rate	H	L/h	641	1234	1890	2235	3981
			M		452	1097	1552	1792	3237
			L		417	740	1162	1514	2748
		Cooling Pressure Drop	H	kPa	21.83	23.95	35.29	25.92	47.48
M			11.65		19.36	24.77	17.41	32.72	
L			10.06		9.53	14.71	12.86	24.37	
Heating Water Flow Rate		H	L/h	649	1267	1948	2325	4137	
		M		458	1126	1600	1864	3363	
		L		422	760	1198	1575	2856	
Heating Pressure Drop		H	kPa	16.8	19.2	28.6	21.3	39	
		M		9	15.5	20.1	14.3	26.8	
		L		7.7	7.6	11.9	10.6	20	
Water Content		L	1.240	1.787	2.364	3.239	3.677		
Construction and Packing Data	Water Connections	Type		Socket(Threaded Female)					
		In	in	3/4"			1"		
	Out	3/4"							
	Condensate Drainage Connection		3/4"						
	Dimensions	L	mm	945	1145	1345	1645	2005	
W		720		780	780	780	780		
H		350		400	400	400	400		

Conditions:

a. Cooling mode:

- Return air temperature: 27C DB/ 19C WB.

- Inlet/ outlet water temperature: 7C/ 12C.

b. Heating mode:

- Return air temperature: 20C.

- Inlet/outlet water temperature: 45/40 C

Product range: PDWD-4R-V-EC 4-row coil 2-pipe with EC motor(s)

PDWD-4R--[Size]-V-EC				400	800	1200	1600	2000	
Unit Configuration		Configuration		2-pipe					
		Number Of Fan Blowers		single	Twin			Four	
		Power Supply		V/Ph/Hz	220~240 / 1 / 50~60				
Performance Data	Air	Air Flow	H	m ³ /hr	658	1322	2244	2632	5264
			M	399	1111	1681	1937	3874	
			L	349	650	1078	1506	3012	
		ESP	H	Pa	120	120	120	120	120
			M	120	120	120	120	120	
			L	50	50	50	50	50	
	Cooling	Total Cooling Capacity	H	kW	3.08	5.82	9.38	11.14	20.24
			M		2.08	5.1	7.55	8.84	16.1
			L		1.87	3.36	5.36	7.19	13.26
		Sensible Cooling Capacity	H		2.09	3.98	6.48	7.64	14.17
			M		1.39	3.46	5.13	6.01	11.14
			L		1.24	2.23	3.57	4.8	9.03
	Sound	Sound Pressure Level (Outlet)		dB(A)	56/53/43	58/56/47	56/52/45	60/58/50	65/61/51
		Sound Pressure Level (Inlet + Radiated)			59/56/46	61/59/50	59/55/48	63/61/53	67/63/53
		Sound Power Level (Outlet)			65/62/52	67/65/56	65/61/54	69/67/59	74/70/60
		Sound Power Level (Inlet + Radiated)			68/65/55	70/68/59	68/64/57	72/70/62	74/72/69
	Electrical	Fan Motor Power	H	W	202	281	310	477	672
			M		121	208	151	304	546
			L		34	65	70	108	280
	Fan Motor Running Current @ H		A	1.76	2.44	2.7	4.15	5.84	
Hydraulic	Cooling Water Flow Rate	H	L/h	293	554	893	1061	1928	
		M		199	486	719	842	1533	
		L		178	320	511	685	1263	
	Cooling Pressure Drop	H	kPa	21.49	13.98	37.63	20.14	70.54	
		M		10.66	11.02	25.47	13.29	46.7	
		L		8.77	5.19	13.76	9.16	32.95	
Water Content		L	1.653	2.383	3.151	4.319	4.902		
Construction and Packing Data		Water Connections		Type	Socket (Threaded Female)				
				in	3/4"			1"	
		Condensate Drainage Connection			3/4"			3/4"	
		Dimensions		L	mm	945	1145	1345	1645
W	720			780		780	780	780	
H	350			400		400	400	400	

Conditions:

a. Cooling mode:

- Return air temperature: 24C DB/ 18C WB.

- Inlet/ outlet water temperature: 5.5C/ 14.5C.

Product range: PDWD-6R-V-EC 6-row coil 2-pipe with EC motor(s)

PDWD-6R-[Size]-V-EC				400	800	1200	1600	2000	
Unit Configuration		Configuration		2-pipe					
		Number Of Fan Blowers		single	Twin			Four	
		Power Supply		V/Ph/Hz	220~240 / 1 / 50~60				
Performance Data	Air	Air Flow	H	m ³ /hr	602	1146	2114	2527	5055
			M		345	972	1549	1809	3618
			L		305	575	937	1386	2773
		ESP	H	Pa	120	120	120	120	120
			M		120	120	120	120	120
			L		50	50	50	50	50
	Cooling	Total Cooling Capacity	H	kW	3.27	6.12	10.46	13.02	23.54
			M		2.14	5.42	8.27	9.96	18.25
			L		1.92	3.58	5.53	8.21	14.91
		Sensible Cooling Capacity	H		2.2	4.11	7.13	8.8	16.24
			M		1.4	3.63	5.56	6.66	12.4
			L		1.25	2.35	3.64	5.41	10
	Sound	Sound Pressure Level (Outlet)		dB(A)	56/53/43	58/56/47	56/52/45	62/59/48	65/63/60
		Sound Pressure Level (Inlet + Radiated)			59/56/46	61/59/50	59/55/48	64/61/50	65/63/60
		Sound Power Level (Outlet)			65/62/52	67/65/56	65/61/54	71/68/57	74/72/69
		Sound Power Level (Inlet + Radiated)			68/65/55	70/68/59	68/64/57	73/70/59	74/72/69
	Electrical	Fan Motor Power	H	W	202	281	310	477	672
			M		121	208	151	304	546
			L		34	65	70	108	280
	Fan Motor Running Current @ H		A	1.76	2.44	2.7	4.15	5.84	
	Hydraulic	Cooling Water Flow Rate	H	L/h	312	583	996	1240	2242
M			204		516	788	949	1739	
L			183		341	527	782	1420	
Cooling Pressure Drop		H	kPa	5.39	7.47	10.18	17.88	62.02	
		M		2.5	6	6.67	11.04	39.25	
		L		2.06	2.84	3.24	7.79	27.27	
Water Content		L	1.653	2.383	3.151	4.319	4.902		
Construction and Packing Data	Water Connections	Type		Socket (Threaded Female)					
		In	in	3/4"			1"		
	Out	3/4"							
	Condensate Drainage Connection		3/4"						
	Dimensions	L	mm	945	1145	1345	1645	2005	
		W		720	780	780	780	780	
H		350		400	400	400	400		

Conditions:

a. Cooling mode:

- Return air temperature: 24C DB/ 18C WB.

- Inlet/ outlet water temperature: 5.5C/ 14.5C.

A.2.2. 4-pipe Systems

Product range: PDWD-3R+1-P-EC 3-row coil for cooling and 1-row coil for heating 4-pipe with EC motor(s)

PDWD-3R+1-[Size]-P-EC				400	800	1200	1600	2000		
Unit Configuration	Configuration			4-pipe						
	Number Of Fan Blowers			Single	Twin			Four		
	Power Supply (V/Ph/Hz)			220~240 / 1 / 50~60						
Performance Data	Air	Air Flow	H	m ³ /hr	658	1322	2244	2632	5264	
			M		399	1111	1681	1937	3874	
			L		349	650	1078	1506	3012	
		ESP	H	Pa	120	120	120	120	120	
			M		120	120	120	120	120	
			L		50	50	50	50	50	
	Cooling	Total Cooling Capacity	H	kW	3.59	6.75	10.7	12.7	22.73	
			M		2.43	5.91	8.62	10.08	18.07	
			L		2.18	3.89	6.12	8.2	14.89	
		Sensible Cooling Capacity	H	kW	2.53	4.8	7.69	9.05	16.62	
			M		1.68	4.17	6.09	7.12	13.07	
			L		1.49	2.68	4.24	5.69	10.59	
	Heating	Heating Capacity	H	kW	3.03	5.64	8.82	10.52	18.93	
			M		2.05	4.94	7.1	8.35	15.05	
			L		1.84	3.25	5.04	6.79	12.4	
		Max. Electric Heater Capacity			3	3	6	9	9	
	Sound	Sound Pressure Level (Outlet)			dB(A)	57/53/43	58/56/47	56/52/45	60/58/50	65/63/60
		Sound Pressure Level (Inlet + Radiated)				59/56/46	61/59/50	59/55/48	63/61/53	65/63/60
		Sound Power Level (Outlet)				66/62/52	67/65/56	65/61/54	69/67/59	74/72/69
		Sound Power Level (Inlet + Radiated)				68/65/55	70/68/59	68/64/57	72/70/62	74/72/69
	Electrical	Fan Motor Power	H	W	202	281	310	477	672	
			M		121	208	151	304	546	
			L		34	65	70	108	280	
	Fan Motor Running Current @ H			A	1.76	2.44	2.7	4.15	5.84	
	Hydraulic	Cooling Water Flow Rate	H	L/h	615	1157	1835	2177	3896	
			M		417	1014	1477	1728	3098	
			L		374	667	1049	1406	2552	
Cooling Pressure Drop		H	kPa	20.28	21.33	33.46	24.71	45.67		
		M		10.06	16.81	22.65	16.31	30.24		
		L		8.28	7.91	12.23	11.24	21.33		
Heating Water Flow Rate		H	L/h	260	483	756	901	1622		
		M		176	423	609	715	1290		
		L		158	279	432	582	1063		
Heating Pressure Drop		H	kPa	21.02	13.24	34.82	18.5	64.47		
	M	10.43		10.44	23.57	12.21	42.68			
	L	8.58		4.91	12.73	8.41	30.11			
cooling water content			L	1.240	1.787	2.364	3.239	3.677		
heating water content			L	0.413	0.596	0.788	1.080	1.226		
Construction and Packing Data	Water Connections	Type		Socket (Threaded Female)						
		In	in	3/4			1"			
	Out									
	Condensate Drainage Connection			3/4			3/4			
	Dimensions	L	mm	945	1145	1345	1645	2005		
W		720		780	780	780	780			
H		350		400	400	400	400			

Conditions:

a. Cooling mode:

- Return air temperature: 27C DB/ 19C WB.

- Inlet/ outlet water temperature: 7C/ 12C.

b. Heating mode:

- Return air temperature: 20C.

- Inlet/outlet water temperature: 65/55 C

Product range: PDWD-4R+2-P-EC 4-row coil for cooling and 2-row coil for heating 4-pipe with EC motor(s)

PDWD-4R+2-[Size]-P-EC				400	800	1200	1600	2000	
Unit Configuration	Configuration			4-pipe					
	Number Of Fan Blowers			Single	Twin			Four	
	Power Supply (V/Ph/Hz)			220~240 / 1 / 50~60					
Performance Data	Air	Air Flow	H	m ³ /hr	602	1146	2114	2527	5055
			M		345	972	1549	1809	3618
			L		305	575	937	1386	2773
		ESP	H	Pa	120	120	120	120	120
			M		120	120	120	120	120
			L		50	50	50	50	50
	Cooling	Total Cooling Capacity	H	kW	2.86	5.2	8.95	10.84	19.67
			M		1.87	4.61	7.08	8.3	15.26
			L		1.68	3.05	4.74	6.83	12.46
		Sensible Cooling Capacity	H	1.94	3.54	6.16	7.42	13.76	
			M	1.24	3.12	4.81	5.62	10.5	
			L	1.1	2.02	3.14	4.56	8.47	
	Heating	Heating Capacity	H	kW	4.59	8.3	14.1	17.12	30.79
			M		3	7.35	11.15	13.1	23.88
			L		2.69	4.85	7.46	10.79	19.51
		Max. Electric Heater Capacity			3	3	6	9	9
	Sound	Sound Pressure Level (Outlet)		dB(A)	56/53/43	58/56/47	56/52/45	60/58/50	65/63/60
		Sound Pressure Level (Inlet + Radiated)			59/56/46	61/59/50	59/55/48	63/61/53	65/63/60
		Sound Power Level (Outlet)			65/62/52	67/65/56	65/61/54	69/67/59	74/72/69
		Sound Power Level (Inlet + Radiated)			68/65/55	70/68/59	68/64/57	72/70/62	74/72/69
	Electrical	Fan Motor Power	H	W	202	281	310	477	672
			M		121	208	151	304	546
			L		34	65	70	108	280
	Fan Motor Running Current @ H			A	1.76	2.44	2.7	4.15	5.84
Hydraulic	Cooling Water Flow Rate	H	L/h	273	496	853	1033	1874	
		M		178	439	674	790	1453	
		L		160	290	451	651	1187	
	Cooling Pressure Drop	H	kPa	18.88	11.43	34.64	19.18	67.01	
		M		8.77	9.19	22.71	11.84	42.41	
		L		7.21	4.36	11.02	8.35	29.47	
	Heating Water Flow Rate	H	L/h	393	711	1208	1467	2639	
		M		257	630	956	1123	2047	
		L		230	416	639	925	1672	
	Heating Pressure Drop	H	kPa	12.89	7.76	23.24	12.82	44.84	
M		5.99		6.24	15.24	7.92	28.38		
L		4.93		2.96	7.39	5.59	19.72		
cooling water content			L	1.653	2.383	3.151	4.319	4.902	
heating water content			L	0.413	0.596	0.788	1.080	1.226	
Construction and Packing Data	Water Connections	Type		Socket (Threaded Female)					
		In	in	3/4"			1"		
	Out			3/4"			3/4"		
	Condensate Drainage Connection				3/4"			3/4"	
	Dimensions	L	mm	945	1145	1345	1645	2005	
W		720		780	780	780	780		
H		350		400	400	400	400		

Conditions:

a. Cooling mode:

- Return air temperature: 24C DB/ 18C WB.
- Inlet/ outlet water temperature: 5.5C/ 14.5C.

b. Heating mode:

- Return air temperature: 20C.
- Inlet/outlet water temperature: 65/55 C

A.3. Sound Data

Model		PDWD-4R-400-V-EC									
Speed		500RPM	600RPM	700RPM	800RPM	900RPM	1000RPM	1100RPM	1200RPM	1300RPM	1400RPM
Sound Power dB(A)		44.7	47.7	51.6	55.0	58.3	60.7	63.2	65.2	66.8	68.2
A-weighted Sound Power in 1/3 Octave-bands under rated ESP	20.0Hz	10.0	8.4	8.0	12.1	9.6	7.2	14.2	20.2	16.6	15.5
	25.0Hz	0.5	8.7	10.3	6.1	3.6	7.3	2.8	6.3	12.2	24.5
	31.5Hz	1.4	9.8	10.3	5.0	4.8	9.1	10.2	6.9	8.7	7.3
	40.0Hz	4.5	6.1	9.5	7.6	10.2	14.2	17.7	14.3	18.4	15.6
	50.0Hz	5.6	9.0	12.4	12.0	10.0	15.1	15.4	15.2	17.3	19.2
	63.0Hz	9.2	11.0	16.7	17.0	19.1	20.9	20.0	23.4	26.1	28.1
	80.0Hz	12.0	18.1	19.5	24.2	22.8	26.4	26.9	32.0	33.4	35.0
	100.0Hz	15.1	20.0	22.4	24.6	30.3	33.2	32.4	34.0	37.7	39.2
	125.0Hz	24.3	26.6	29.9	34.2	36.7	37.4	41.6	44.6	46.3	45.3
	160.0Hz	26.9	29.3	37.6	38.2	43.1	43.9	48.5	50.8	53.6	55.9
	200.0Hz	39.0	33.0	37.7	42.6	47.1	49.8	53.5	55.8	55.7	56.9
	250.0Hz	26.5	29.8	33.0	37.5	39.8	42.7	45.2	48.1	50.1	51.7
	315.0Hz	33.2	36.4	40.2	43.2	45.3	47.2	50.5	52.2	54.2	54.4
	400.0Hz	34.8	40.0	42.0	44.6	47.8	49.9	50.3	52.6	53.9	55.9
	500.0Hz	37.8	41.4	45.5	47.6	50.4	54.0	55.3	56.7	57.3	59.6
	630.0Hz	32.3	38.7	41.7	44.0	47.5	49.9	52.0	53.7	54.6	56.6
	800.0Hz	33.4	38.7	42.3	46.4	49.8	52.5	54.3	56.1	58.0	59.0
	1000.0Hz	32.6	37.2	40.8	45.1	48.6	51.0	52.7	55.0	57.1	58.3
	1250.0Hz	30.4	35.6	39.7	42.9	45.7	48.9	51.3	54.1	55.4	57.1
	1600.0Hz	28.5	35.0	39.9	42.4	45.6	48.3	50.5	52.8	55.4	57.3
2000.0Hz	25.8	32.5	37.9	41.7	45.2	48.0	49.8	52.0	54.3	56.2	
2500.0Hz	22.2	29.0	34.3	38.8	42.3	45.6	48.0	49.9	51.5	54.1	
3150.0Hz	18.8	25.6	30.5	35.0	39.5	42.8	45.8	48.2	49.8	52.1	
4000.0Hz	17.8	23.2	28.0	32.8	37.1	40.4	43.5	46.3	48.1	51.1	
5000.0Hz	16.1	19.8	24.6	29.5	34.2	37.9	40.5	43.1	45.5	48.0	
6300.0Hz	15.5	18.4	23.1	27.8	32.5	36.6	39.6	42.3	44.4	46.8	
8000.0Hz	15.0	16.9	21.0	25.9	31.2	34.6	38.3	41.3	43.5	45.8	
10000.0Hz	13.0	13.4	15.4	20.3	25.8	29.6	33.7	37.3	40.0	42.6	
12500.0Hz	9.9	10.3	11.2	14.5	19.8	23.8	27.7	31.3	34.3	37.4	
16000.0Hz	18.6	19.9	20.7	21.2	21.2	21.7	22.4	24.3	25.9	28.9	

Model	PDWD(4R)-800-V-EC										
Speed	500RPM	600RPM	700RPM	800RPM	900RPM	1000RPM	1100RPM	1200RPM	1300RPM	1400RPM	
Sound Power dB(A)	43.7	48.5	52.4	55.9	58.8	61.3	63.7	66.1	68.0	69.6	
A-weighted Sound Power in 1/3 Octave-bands under rated ESP	20.0Hz	-1.7	0.5	1.1	-1.3	6.9	6.9	1.8	5.2	14.5	14.6
	25.0Hz	-3.1	-4.6	2.3	-0.3	1.5	1.3	2.5	0.5	8.4	14.0
	31.5Hz	-6.1	-4.1	8.4	3.0	5.8	4.7	12.5	9.0	11.7	15.4
	40.0Hz	3.4	5.6	6.1	8.9	15.1	9.2	17.2	19.8	19.4	20.1
	50.0Hz	3.6	7.1	9.1	10.2	10.8	14.2	17.8	17.7	17.1	20.1
	63.0Hz	9.5	8.3	18.5	19.0	21.3	23.2	26.0	24.7	29.9	28.1
	80.0Hz	18.5	22.7	23.4	28.1	26.1	28.9	29.5	33.1	33.6	35.6
	100.0Hz	20.8	23.7	26.6	32.4	34.3	35.3	37.1	41.7	41.0	40.1
	125.0Hz	24.2	29.8	32.8	38.2	43.1	43.7	45.7	48.8	47.8	50.1
	160.0Hz	28.9	31.7	39.9	43.6	49.1	49.3	51.8	55.2	54.3	56.9
	200.0Hz	32.2	31.0	37.9	41.3	45.6	48.3	51.0	56.6	55.4	57.4
	250.0Hz	28.3	31.1	35.4	38.4	42.4	46.4	47.6	50.7	52.9	57.0
	315.0Hz	33.2	36.2	41.7	43.2	44.8	48.9	51.3	52.4	56.5	58.1
	400.0Hz	33.4	39.3	42.0	45.7	47.6	50.8	52.6	54.3	55.8	58.5
	500.0Hz	36.4	42.1	44.8	48.0	49.5	52.5	53.7	57.4	58.6	61.5
	630.0Hz	33.9	38.9	41.8	45.7	48.8	50.4	53.9	55.3	57.0	58.8
	800.0Hz	32.8	39.0	42.6	46.2	49.1	50.9	53.8	55.4	57.4	58.2
	1000.0Hz	32.9	38.5	42.3	45.4	48.6	50.9	52.9	55.5	56.7	58.8
	1250.0Hz	32.0	37.3	41.0	44.7	47.6	50.1	52.1	55.1	56.1	58.3
	1600.0Hz	31.3	36.1	40.0	44.2	47.0	49.2	51.2	54.3	56.3	57.8
2000.0Hz	26.5	34.4	38.2	42.6	45.5	48.0	50.6	53.4	54.7	57.0	
2500.0Hz	24.2	30.6	36.5	40.9	44.7	46.8	49.2	51.9	54.1	55.8	
3150.0Hz	20.5	27.1	32.8	38.1	41.6	44.6	47.2	49.7	51.9	53.5	
4000.0Hz	18.3	23.9	29.7	35.2	38.8	41.8	45.1	48.2	50.3	52.1	
5000.0Hz	16.7	20.6	26.6	31.9	36.1	39.5	42.9	45.7	48.1	50.4	
6300.0Hz	16.0	18.6	24.5	30.6	34.9	38.7	41.9	44.5	47.0	49.1	
8000.0Hz	15.9	18.2	22.4	28.1	32.8	37.4	40.8	44.0	46.5	48.5	
10000.0Hz	13.0	13.9	17.3	23.0	27.4	31.5	35.7	39.7	42.7	45.3	
12500.0Hz	10.3	10.8	12.3	16.0	20.2	24.4	28.2	32.3	35.5	38.5	
16000.0Hz	28.1	30.0	31.3	31.9	31.9	31.6	31.0	31.2	31.4	31.9	

Model	PDWD(4R)-1200-V-EC										
Speed	500RPM	600RPM	700RPM	800RPM	900RPM	1000RPM	1100RPM	1200RPM	1300RPM	1400RPM	
Sound Power dB(A)	45.6	49.7	53.4	56.7	59.9	63.9	65.0	67.2	69.3	71.4	
A-weighted Sound Power in 1/3 Octave-bands under rated ESP	20.0Hz	0.0	3.9	11.0	-2.8	8.0	7.2	11.0	14.8	16.0	15.3
	25.0Hz	2.8	-0.7	1.6	4.7	3.2	9.1	9.4	10.5	11.9	15.8
	31.5Hz	5.7	3.6	4.2	6.9	7.9	13.5	12.6	15.2	18.2	15.4
	40.0Hz	14.3	10.5	11.6	9.4	18.9	17.2	16.9	18.5	18.1	16.6
	50.0Hz	8.9	7.9	15.7	14.8	16.2	16.9	19.4	20.5	23.1	25.5
	63.0Hz	13.4	18.8	17.1	23.5	25.0	24.9	27.3	31.5	30.6	32.5
	80.0Hz	12.3	19.8	24.6	28.6	29.2	32.9	32.8	35.4	37.2	38.3
	100.0Hz	18.3	24.6	30.1	32.5	34.0	37.2	40.6	40.4	46.8	43.4
	125.0Hz	21.3	29.8	32.7	38.4	41.0	43.6	47.7	49.3	50.3	53.0
	160.0Hz	28.0	31.7	34.1	40.7	43.0	48.4	52.1	52.4	54.8	57.2
	200.0Hz	28.4	32.8	38.8	39.0	43.8	48.1	50.7	53.0	55.4	60.4
	250.0Hz	28.0	32.0	35.2	39.3	43.8	47.3	49.4	52.4	54.5	57.0
	315.0Hz	32.5	37.4	40.2	43.7	45.9	50.1	52.5	54.8	56.6	58.7
	400.0Hz	36.3	41.3	44.6	46.2	48.6	54.4	53.8	55.0	56.8	59.8
	500.0Hz	36.3	39.5	44.6	46.3	49.5	51.2	53.3	54.9	56.8	58.3
	630.0Hz	34.8	39.1	43.1	46.2	48.9	51.1	54.3	56.1	57.1	59.1
	800.0Hz	35.7	39.9	44.6	48.6	51.4	53.2	56.7	58.4	60.3	60.1
	1000.0Hz	33.3	39.1	43.5	47.1	49.8	52.7	55.0	57.2	59.5	60.3
	1250.0Hz	32.3	39.1	43.1	46.7	49.8	51.9	54.8	57.3	59.0	60.9
	1600.0Hz	31.1	36.9	41.2	45.6	48.4	51.4	53.8	56.0	58.6	60.5
2000.0Hz	28.7	35.4	40.7	44.7	47.5	56.0	53.9	55.4	58.2	60.0	
2500.0Hz	25.3	32.2	38.5	43.1	46.3	50.0	51.5	53.9	56.2	58.1	
3150.0Hz	23.0	29.8	35.6	40.1	43.4	50.6	49.5	52.1	54.1	56.2	
4000.0Hz	20.7	27.0	33.0	37.8	41.9	49.1	48.2	51.0	53.4	55.4	
5000.0Hz	19.0	24.6	30.8	35.5	39.5	46.2	46.0	48.9	51.3	53.4	
6300.0Hz	21.4	24.7	30.2	34.8	38.9	47.6	45.9	48.6	51.1	53.1	
8000.0Hz	39.3	40.2	40.6	41.7	43.3	46.8	46.6	49.1	51.1	53.0	
10000.0Hz	23.5	25.5	27.1	30.5	34.1	43.5	40.8	43.8	46.5	48.9	
12500.0Hz	16.7	18.0	19.2	21.7	25.9	36.0	34.0	37.4	40.4	43.2	
16000.0Hz	25.5	25.3	25.2	24.8	25.1	28.8	27.7	29.8	32.0	34.4	

Model	PDWD-4R-1600-V-EC										
Speed	500RPM	600RPM	700RPM	800RPM	900RPM	1000RPM	1100RPM	1200RPM	1300RPM	1400RPM	
Sound Power dB(A)	48.0	52.0	55.8	59.2	62.0	64.7	67.0	69.5	71.3	72.2	
A-weighted Sound Power in 1/3 Octave-bands under rated ESP	20.0Hz	-0.6	4.5	-0.7	-0.1	5.4	11.2	13.4	19.3	15.8	20.4
	25.0Hz	-1.8	0.2	4.2	-0.3	1.2	6.7	9.7	5.8	13.0	23.0
	31.5Hz	6.6	2.1	7.2	4.4	11.0	12.3	10.3	10.4	16.3	15.4
	40.0Hz	7.6	10.2	8.9	13.4	12.7	17.0	19.5	16.1	18.1	20.1
	50.0Hz	8.1	9.1	14.2	17.6	17.1	18.7	24.8	22.8	23.1	23.8
	63.0Hz	15.4	16.1	21.6	18.9	25.4	25.8	28.9	29.8	32.5	35.2
	80.0Hz	18.1	24.9	25.0	27.2	29.8	30.6	36.8	36.9	36.8	39.4
	100.0Hz	21.2	26.8	32.9	35.7	37.3	38.4	39.5	36.8	43.8	44.4
	125.0Hz	27.3	33.7	35.0	39.3	44.6	46.4	47.3	52.1	51.1	50.7
	160.0Hz	30.4	34.9	42.9	43.9	45.7	51.0	52.0	55.1	57.6	55.4
	200.0Hz	31.5	37.0	40.9	45.6	48.8	52.5	53.4	56.8	58.2	59.1
	250.0Hz	31.5	36.7	39.1	43.1	47.8	50.1	52.0	55.9	55.9	59.4
	315.0Hz	33.6	38.9	42.6	45.8	48.2	52.7	53.2	57.9	58.5	59.1
	400.0Hz	38.3	42.9	45.9	47.7	50.3	52.7	55.7	57.3	59.2	60.0
	500.0Hz	37.3	40.7	45.2	47.4	49.9	52.2	55.1	56.7	57.9	58.8
	630.0Hz	36.7	41.1	45.9	49.4	51.7	53.2	55.4	56.3	59.6	59.3
	800.0Hz	35.1	40.9	44.8	47.7	51.4	53.3	56.4	57.3	59.2	59.8
	1000.0Hz	36.1	41.3	45.5	48.4	51.1	53.7	56.0	57.8	59.4	61.2
	1250.0Hz	37.0	41.6	45.9	49.2	52.3	54.5	56.6	59.0	60.9	61.9
	1600.0Hz	36.0	41.4	45.1	48.8	51.4	54.1	57.1	59.8	61.4	62.3
2000.0Hz	32.5	39.0	43.8	47.9	50.5	52.8	55.2	58.2	59.8	60.7	
2500.0Hz	29.7	36.8	42.2	46.1	49.7	52.4	54.5	56.8	58.9	59.9	
3150.0Hz	27.6	33.7	39.6	44.2	48.3	50.9	53.6	56.1	57.9	58.9	
4000.0Hz	25.6	32.2	37.6	42.0	45.7	49.1	52.3	54.7	57.1	58.1	
5000.0Hz	23.8	29.6	35.3	39.7	43.5	46.7	50.1	52.4	54.9	55.9	
6300.0Hz	25.9	30.4	35.4	39.9	43.7	47.0	49.9	52.6	54.6	55.8	
8000.0Hz	41.8	43.0	44.1	45.2	46.9	48.7	51.1	53.2	54.6	55.7	
10000.0Hz	26.8	28.7	31.1	35.2	38.6	41.9	45.6	48.6	50.5	51.7	
12500.0Hz	21.5	23.2	25.4	29.8	33.6	36.7	40.4	43.4	45.5	46.9	
16000.0Hz	32.2	32.3	32.1	31.9	32.2	32.5	34.4	36.1	37.7	38.7	

Model	PDWD-4R-2000-V-EC										
Speed	500RPM	600RPM	700RPM	800RPM	900RPM	1000RPM	1100RPM	1200RPM	1300RPM	1400RPM	
Sound Power dB(A)	49.7	53.6	57.5	61.4	64.3	67.1	69.5	71.6	73.6	75.5	
A-weighted Sound Power in 1/3 Octave-bands under rated ESP	20.0Hz	-5.5	4.0	-3.0	4.8	4.4	10.6	17.5	24.5	25.5	17.8
	25.0Hz	-6.0	-2.5	2.4	6.1	2.1	6.7	10.2	10.0	18.9	23.4
	31.5Hz	6.4	4.2	6.8	5.3	11.7	14.6	16.8	13.4	18.8	21.3
	40.0Hz	10.0	13.5	8.9	15.3	16.8	18.2	23.0	18.4	27.4	26.9
	50.0Hz	10.1	11.7	19.4	19.2	21.0	23.0	25.2	24.3	28.4	28.9
	63.0Hz	22.5	20.0	24.0	26.3	25.7	31.3	30.9	34.1	37.0	39.7
	80.0Hz	18.1	24.4	30.0	29.4	34.4	36.9	38.6	41.5	40.0	42.1
	100.0Hz	23.9	26.7	31.4	36.8	36.3	38.9	44.2	45.1	48.3	48.7
	125.0Hz	28.0	34.2	37.4	41.2	42.5	45.3	48.6	50.2	51.4	54.8
	160.0Hz	30.4	35.2	42.5	45.4	46.7	50.9	53.7	56.0	57.5	57.2
	200.0Hz	31.9	36.3	40.8	45.1	48.9	51.7	53.2	57.0	58.0	59.8
	250.0Hz	34.6	38.0	41.8	45.0	49.7	52.0	54.8	55.7	59.4	60.7
	315.0Hz	36.4	40.8	43.7	47.9	51.1	52.1	55.1	57.5	59.1	62.4
	400.0Hz	38.9	42.7	46.1	49.7	51.7	53.8	56.5	57.9	61.1	62.2
	500.0Hz	40.8	44.2	47.7	49.7	53.1	54.3	55.5	58.3	60.3	61.2
	630.0Hz	37.6	41.8	45.5	49.1	52.5	53.5	55.3	57.8	59.5	61.2
	800.0Hz	39.7	44.1	48.4	53.2	55.9	59.7	60.3	61.3	64.3	65.4
	1000.0Hz	39.6	44.5	48.8	53.0	56.5	59.4	61.4	62.2	65.0	66.7
	1250.0Hz	37.1	42.8	47.7	51.1	54.9	57.9	59.5	62.4	63.8	65.5
	1600.0Hz	36.4	42.0	46.3	50.2	53.2	56.7	59.5	62.3	63.9	66.0
2000.0Hz	33.9	39.8	45.3	48.8	52.4	55.5	57.7	60.5	62.6	65.2	
2500.0Hz	30.1	36.4	42.3	46.5	50.3	53.4	55.9	58.2	60.3	62.5	
3150.0Hz	29.1	34.9	40.6	45.7	49.3	53.0	54.9	57.5	59.3	61.7	
4000.0Hz	26.8	33.4	39.0	44.2	47.8	51.6	54.1	56.6	58.7	60.6	
5000.0Hz	23.3	30.3	36.5	41.8	45.8	49.6	52.0	54.8	56.9	59.3	
6300.0Hz	26.8	29.8	35.0	40.4	44.7	48.8	51.1	53.7	55.8	58.2	
8000.0Hz	43.7	44.7	45.4	46.5	47.9	50.3	52.2	54.0	55.9	58.1	
10000.0Hz	28.8	30.0	31.8	35.2	39.3	44.7	46.7	49.6	52.1	54.4	
12500.0Hz	22.0	23.1	24.5	27.9	32.5	39.8	40.4	43.4	46.5	49.1	
16000.0Hz	30.5	30.4	30.0	30.7	31.1	34.2	34.5	36.3	38.2	40.5	

A.4. Coil Data

2-Pipe Systems (3-Row Coil)

Model	Fin height (mm)	Fin Length (mm)	Fins per Inch	No. of Rows	Fin width (mm)	No. of Circuits	Tube Ø (mm)
PDWD-3R-400	250	680	12.7	3	66	3	9.52
PDWD-3R-800	300	880				5	
PDWD-3R-1200	300	1080				6	
PDWD-3R-1600	300	1380				8	
PDWD-3R-2000	300	1740				10	

2-Pipe Systems (4-Row Coil)

Model	Fin height (mm)	Fin Length (mm)	Fins per Inch	No. of Rows	Fin width (mm)	No. of Circuits	Tube Ø (mm)
PDWD-4R-400	250	680	12.7	4	88	2	9.52
PDWD-4R-800	300	880				4	
PDWD-4R-1200	300	1080				4	
PDWD-4R-1600	300	1380				6	
PDWD-4R-2000	300	1740				6	

2-Pipe Systems (6-Row Coil)

Model	Fin height (mm)	Fin Length (mm)	Fins per Inch	No. of Rows	Fin width (mm)	No. of Circuits	Tube Ø (mm)
PDWD-6R-400	250	680	12.7	6	132	4	9.52
PDWD-6R-800	300	880				6	
PDWD-6R-1200	300	1080				8	
PDWD-6R-1600	300	1380				8	
PDWD-6R-2000	300	1740				8	

4-Pipe Systems (1 row Auxiliary Heating Coil)

Model	Fin height (mm)	Fin Length (mm)	Fins per Inch	No. of Rows	Fin width (mm)	No. of Circuits	Tube Ø (mm)
PDWD-1R-400	250	680	12.7	1	22	1	9.52
PDWD-1R-800	300	880				2	
PDWD-1R-1200	300	1080				2	
PDWD-1R-1600	300	1380				3	
PDWD-1R-2000	300	1740				3	

4-Pipe Systems (2 row Auxiliary Heating Coil)

Model	Fin height (mm)	Fin Length (mm)	Fins per Inch	No. of Rows	Fin width (mm)	No. of Circuits	Tube Ø (mm)
PDWD-1R-400	250	680	12.7	2	44	2	9.52
PDWD-1R-800	300	880				3	
PDWD-1R-1200	300	1080				4	
PDWD-1R-1600	300	1380				5	
PDWD-1R-2000	300	1740				5	

A.5. Dimension Drawings

2-pipe: PDWD-3R, 4R, 6R -400

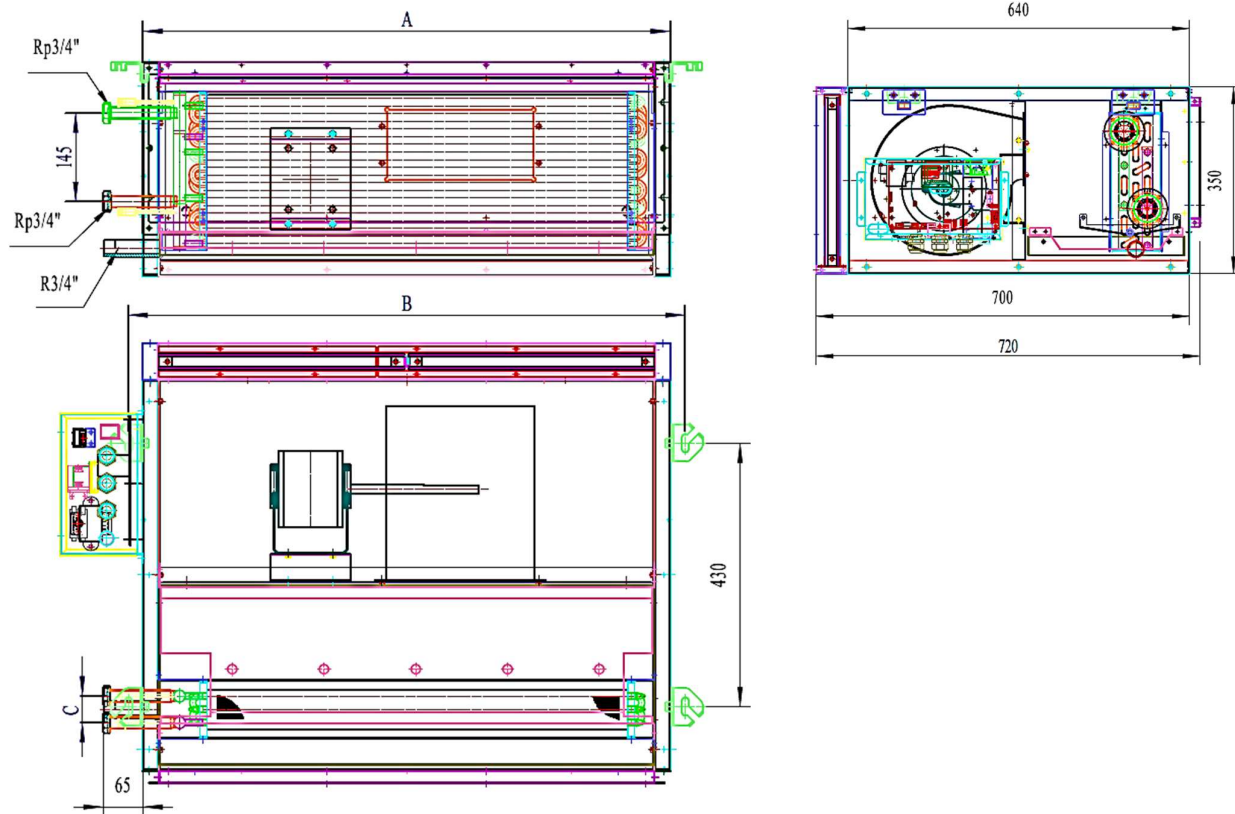

Model	A	B	C
PDWD-3R-400	862	910	43.3
PDWD-4R-400	862	910	65
PDWD-6R-400	862	910	108.3

2-pipe: PDWD-3R, 4R, 6R -2000

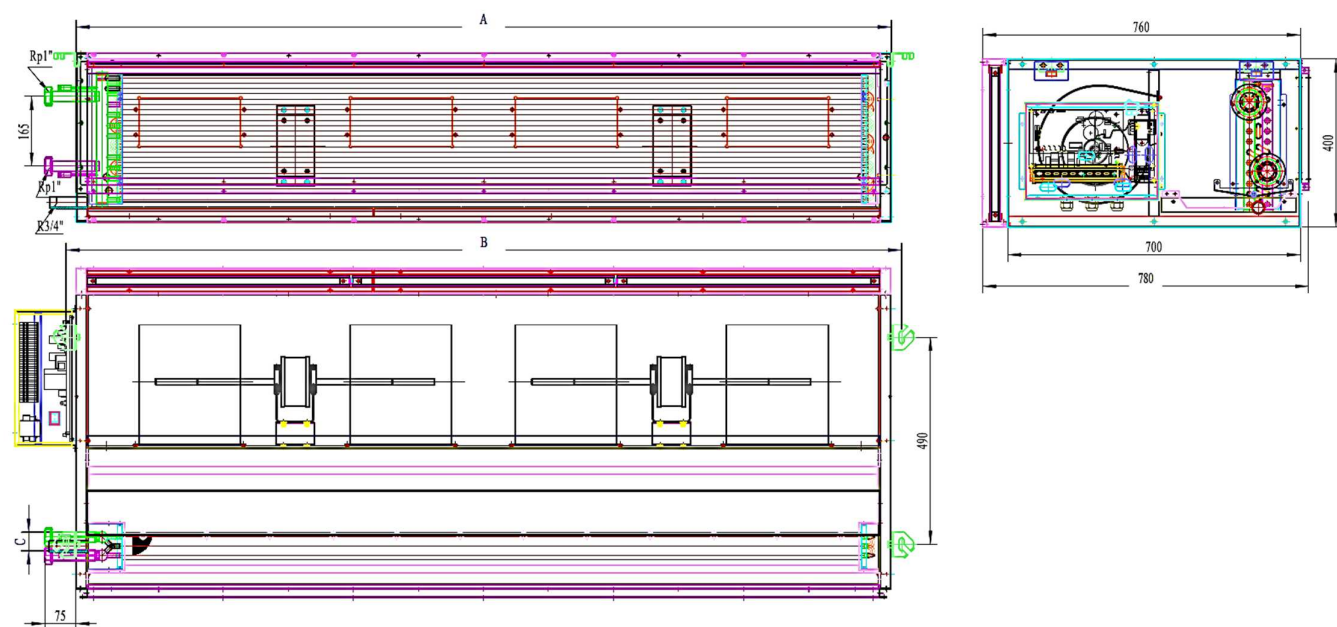

Model	A	B	C
PDWD-3R-2000	1928	1976	43.3
PDWD-4R-2000	1928	1976	65
PDWD-6R-2000	1928	1976	108.3

2-pipe: PDWD-3R, 4R, 6R -800~1600

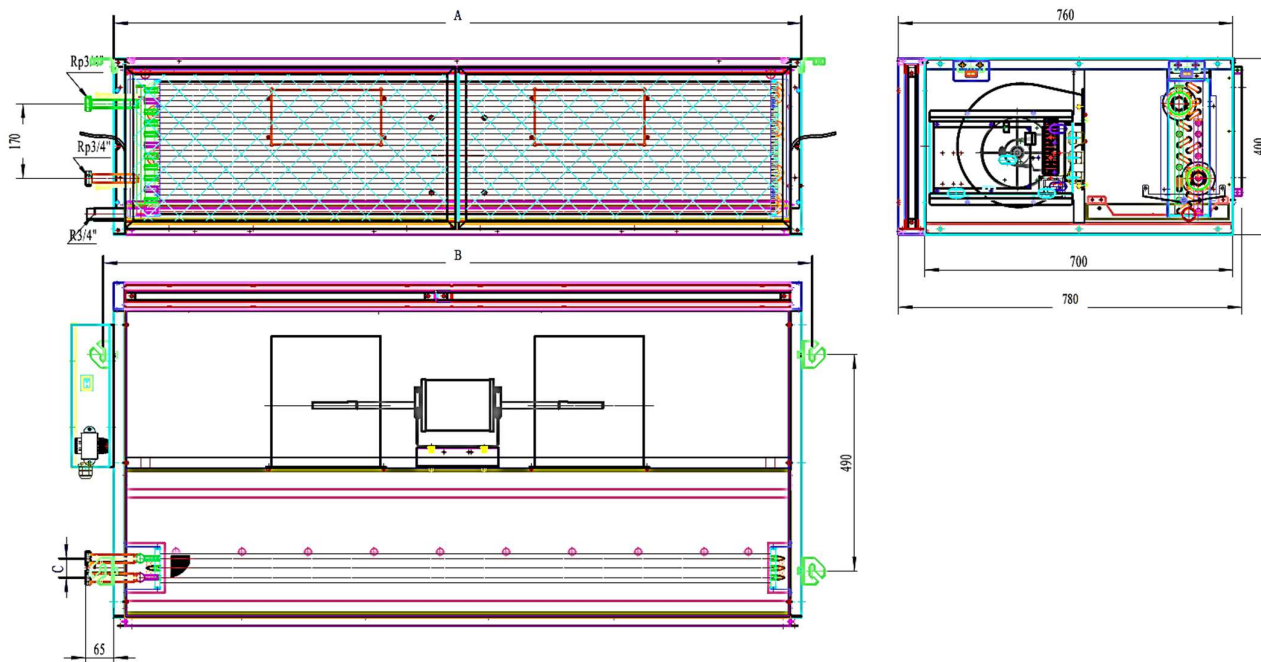

Model	A	B	C
PDWD-3R-800	1062	1110	43.3
PDWD-3R-1200	1262	1310	43.3
PDWD-3R-1600	1562	1610	43.3
PDWD-4R-800	1062	1110	65
PDWD-4R-1200	1262	1310	65
PDWD-4R-1600	1562	1610	65
PDWD-6R-800	1062	1110	108.3
PDWD-6R-1200	1262	1310	108.3
PDWD-6R-1600	1562	1610	108.3

4-pipe: PDWD-3R+1, 4R+1-400

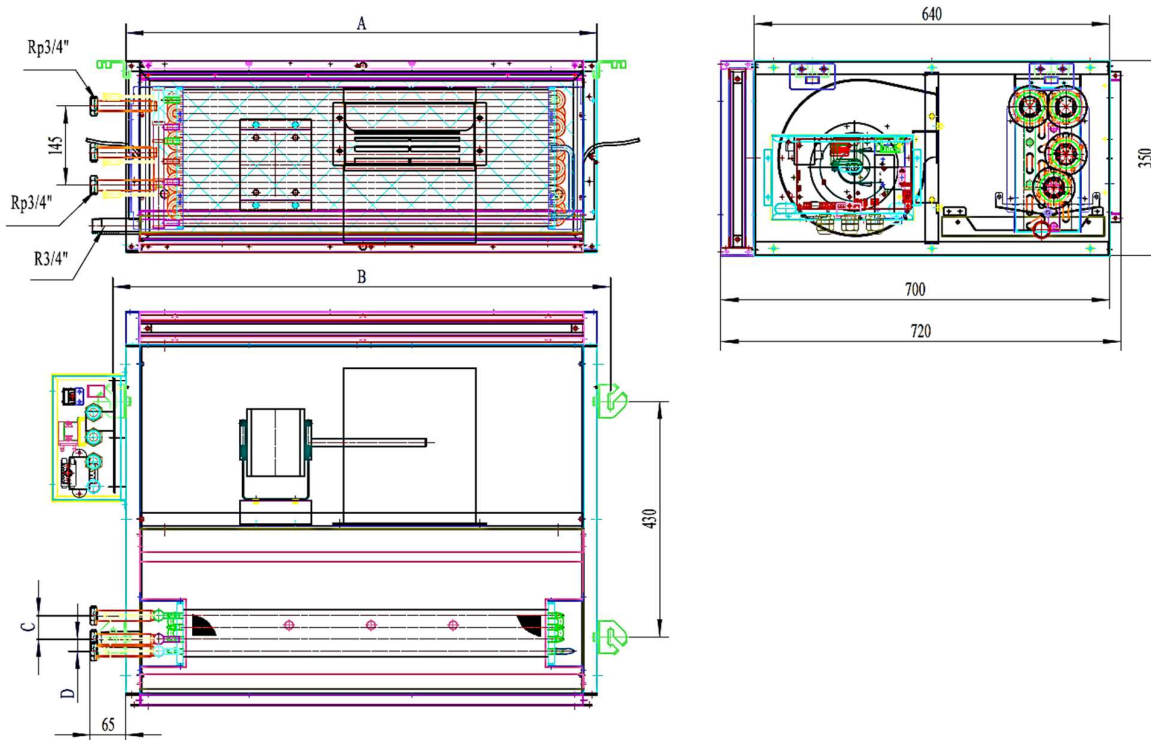

Model	A	B	C	D
PDWD-3R+1-400	862	910	43.3	21.65
PDWD-4R+1-400	862	910	65	21.65

4-pipe: PDWD-3R+1, 4R+1-800~1600

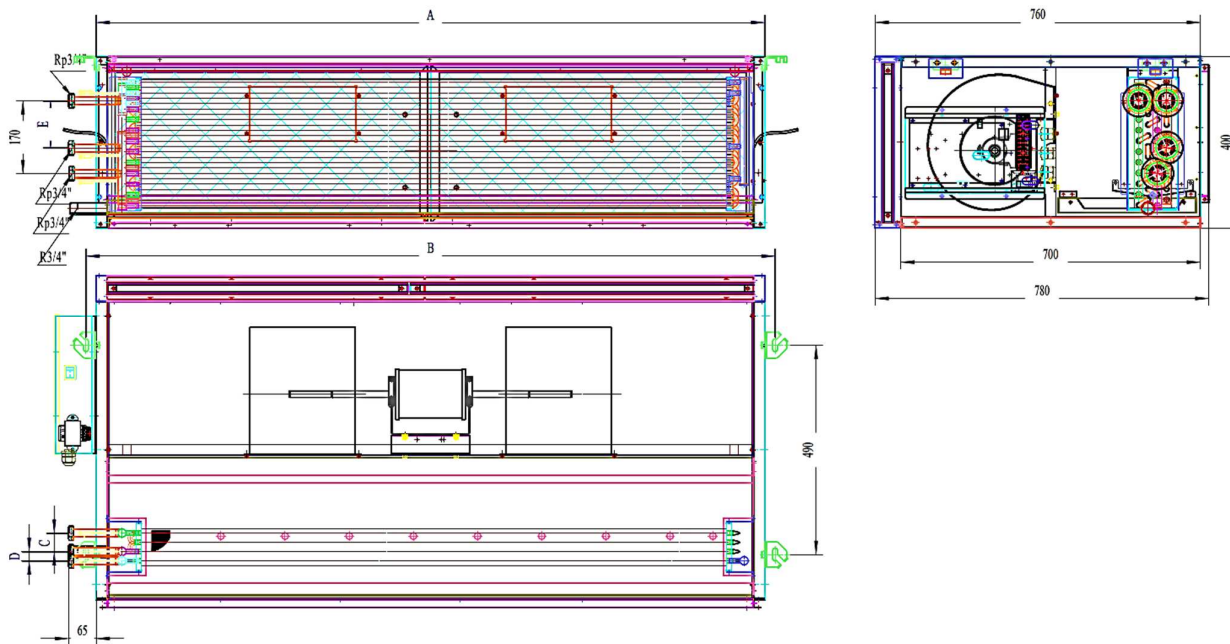

Model	A	B	C	D	E
PDWD-3R+1-800	1062	1110	43.3	21.65	110
PDWD-3R+1-1200	1262	1310	43.3	21.65	110
PDWD-3R+1-1600	1562	1610	43.3	21.65	110
PDWD-4R+1-800	1062	1110	65	21.65	105
PDWD-4R+1-1200	1262	1310	65	21.65	105
PDWD-4R+1-1600	1562	1610	65	21.65	105

4-pipe: PDWD-3R+1, 4R+1-2000

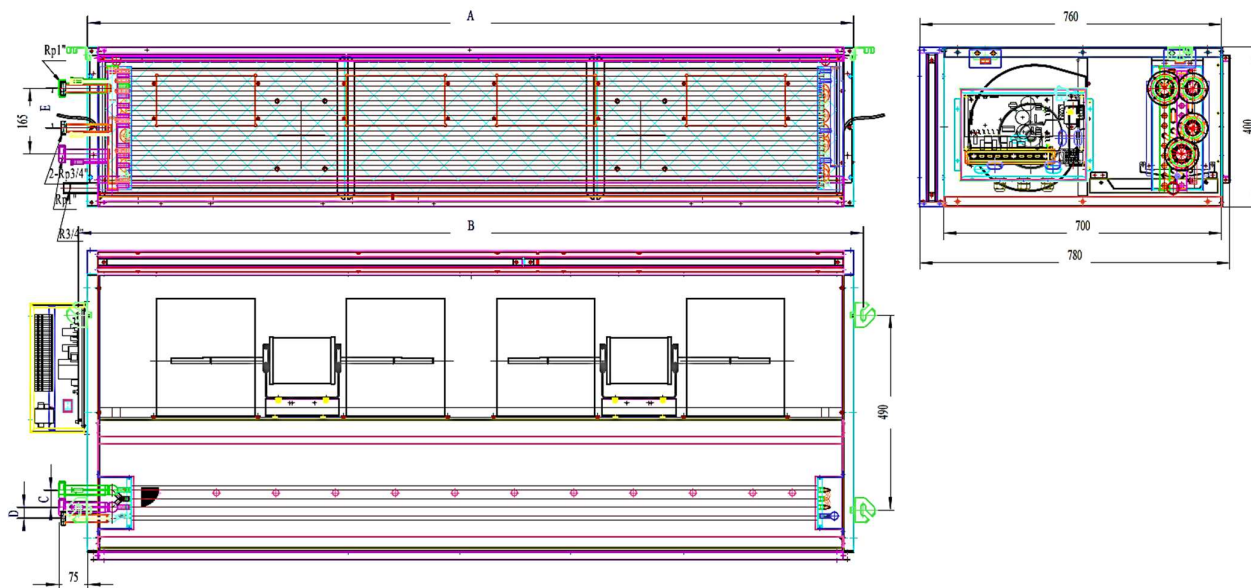

Model	A	B	C	D	E
PDWD-3R+1-2000	1928	1976	43.3	21.65	100
PDWD-4R+1-2000	1928	1976	54.95	21.65	105

B. Installation

B.1. Safety Precautions

- When installing, performing maintenance or servicing Polar Air fan coil units observe the precautions stated in this manual as well as those stated on the labels attached to the unit.
- Ensure all local and national safety codes, laws, regulations, as well as general electrical and mechanical safety guidelines are followed for installation, maintenance and service.
- The appliance is for indoor use only.
- Ensure the correct power supply is provided.
- If the power supply cord is damaged, it must be replaced by qualified personnel.
- Installing and servicing fan coil unit should be performed by qualified service personnel only.
- This appliance is not intended for use by persons (including children) with reduced physical, sensory or mental capabilities, or persons lacking in experience and knowledge of the appliance, unless they have been given supervision or instruction concerning it.
- User of this appliance is responsible for his/her own safety.
- Warranty shall be voided if installation instructions and safety precaution stated in this manual are not observed.
- The unit should only be switched off by using the ON-OFF button on the control interface.
- To select proper pipe pliers for pipe connections, according to pipe diameter to avoid damaging units by excessive force.
- When units are in cooling mode, cooling water temperature ≥ 7 °C is suggested; When units are in heating mode, hot water temperature ≤ 60 °C is suggested.

CAUTIONS

Before any service or maintenance operations turn off the mains electrical supply.

DO NOT turn OFF the main power supply when the unit is operating. Turn off the unit BEFORE turning off the main power

B.2. Location

Before installing and running the unit, please check the following:

1. There must be enough space for unit installation and maintenance. Please refer to below figure for the unit's outlines and dimensions and for the minimum distance between the unit and the obstacle/ any obstructions/ its surroundings.
2. Please ensure there is enough space for piping connections and electrical wiring.
3. Check whether the hanging rods can support the weight of the unit (see specification table for weight of the unit).
4. The unit must be installed horizontally to ensure proper operation and condensate draining.
5. The external static pressure of the ducting must be within the unit's static pressure range.
6. Confirm that the unit has been switched OFF before installing or servicing the unit.

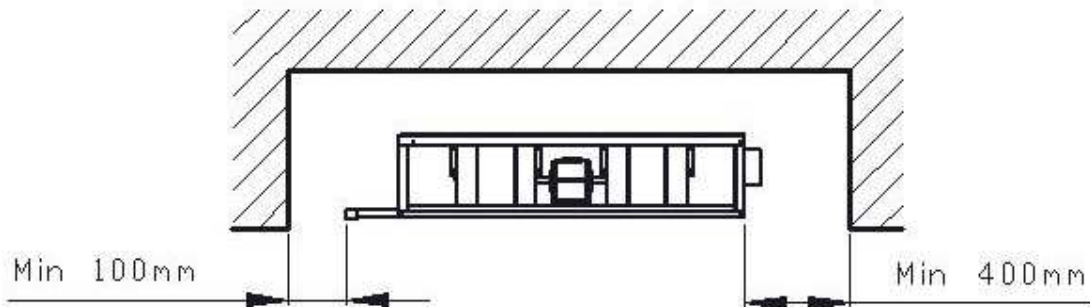

B.3. Installation Procedures

1. The unit is designed to be installed in a concealed ceiling. Installation and maintenance should be performed by qualified personnel who are familiar with local codes and regulations, and are experienced with this type of appliance.
2. Please refer to the pictures below for installation procedures.

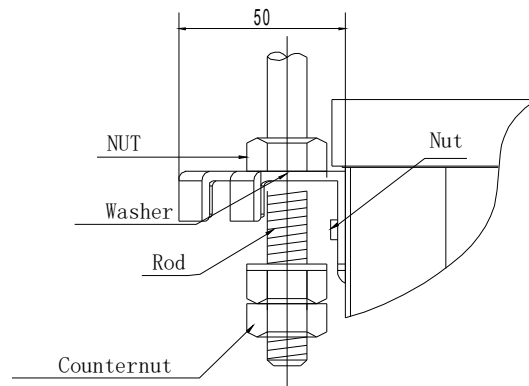
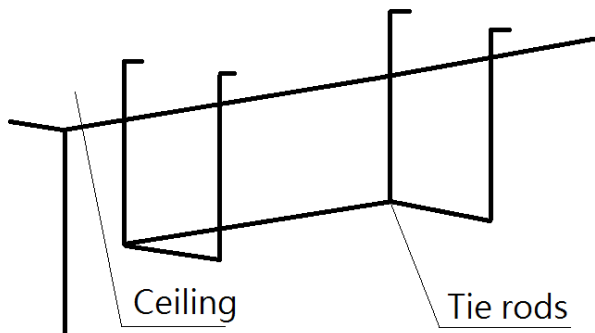

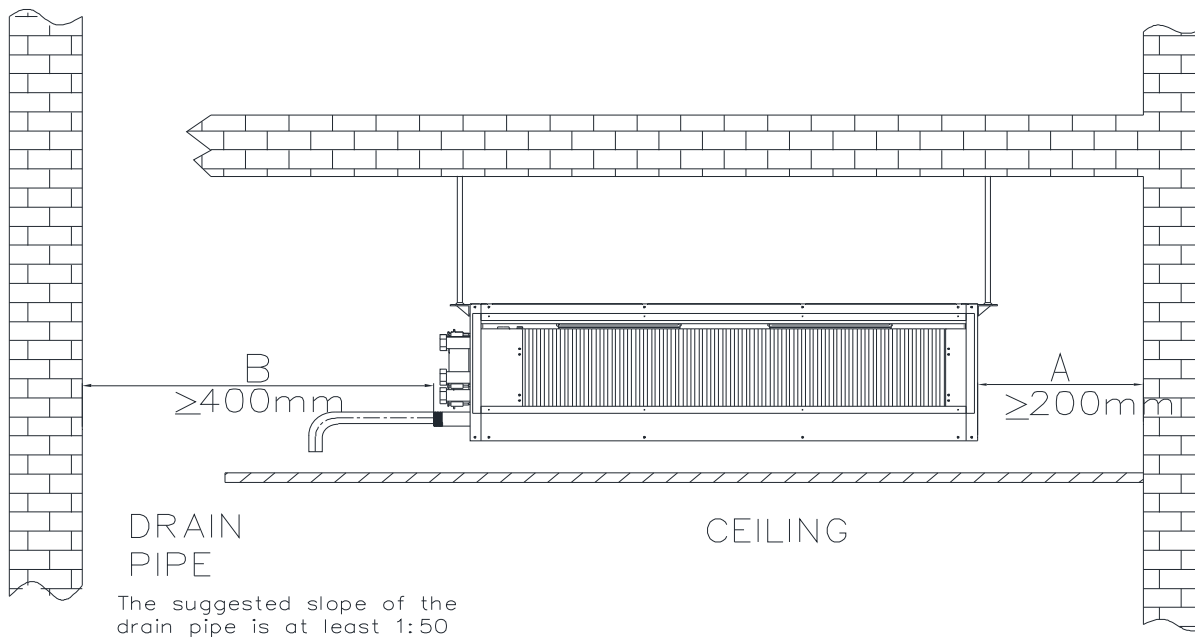

CAUTIONS

Make sure the top of the unit is level after installation. The drain pan is designed with a slight gradient to facilitate drainage.

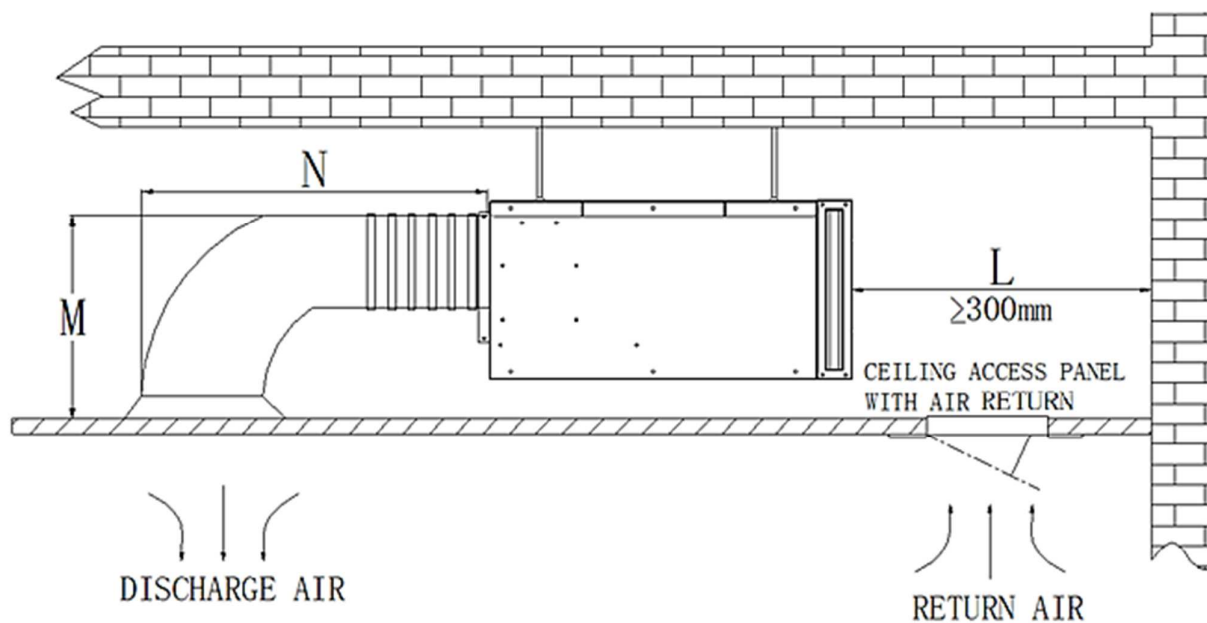

CAUTIONS

Dimension M and N are determined by air duct design.

Air duct should be fire-proof. Please refer to concerned country national and local regulation.

B.4. Insulation

1. The insulation design and materials should be complying with local and national codes and regulations.
2. Chilled water pipes and all parts on the pipes should be insulated.
3. It is also necessary to insulate the air duct.

B.5. Air Duct Connection

1. Circulatory air pressure drop should be within External Static Pressure.
2. Galvanized steel air ducts are suitable.
3. Make sure there is no leak of air.
4. Air duct should be fire-proof, refer to concerned country national and local regulations.

B.6. Service Connection

1. Using suitable fittings as water pipe connections with reference to the outline and dimensions.
2. The water inlet is on the bottom while outlet on top.
3. The connection must be concealed with rubberized fabric to avoid leakage.
4. Drain pipe can be PVC or steel.
5. Tightening torque should not be too high when connecting water pipes, in order to avoid brass deformation or water-leakage by torsion split.
6. The suggested slope of the drain pipe is at least 1:50.

CAUTION

When connecting pipe to fan coil unit, do not bend or reposition the coil header for alignment purposes. This could cause a tubing fracture resulting in a water leak when water pressure is applied to the system.

B.7. Unit Operation

1. Confirm air has been properly blown and there is waterflow through the coil.
2. Confirm fan wheel is rotating and air is discharged from unit supply opening.
3. Confirm power voltage between Terminals L1 and N.
4. Confirm thermostat voltage (24V or 12V).
5. Verify desired fan speed is receiving power from the thermostat or control box.
6. Check functionality of motor with a call for heating or cooling.
7. Confirm that the system ESP is proceeding as planned.
8. Confirm control valve(s) functionality.

C. Maintenance

C.1. General Maintenance

1. Installation and maintenance should be performed by qualified personnel who are familiar with local codes and regulations, and are also experienced with this type of appliance.
2. Confirm that the unit has been switched OFF before installing or servicing the unit.
3. A good general maintenance plan will prevent damage to and unexpected shutting down of the equipment.
4. Dirty filters reduce air flow as well as unit performance. Therefore, changing or cleaning the filters is very important. Check the cleanliness of the filter and replace or clean as required monthly.
5. Coils should be cleaned with compressed air or water to remove dust, dirt or lint. They can be brushed with a soft brush or vacuumed with a vacuum cleaner.
6. If the water coil is not being used during the winter season it should be drained, or an anti-freezing solution should be added to the water circuit to avoid freezing.

C.2. Regular Maintenance

1. Inspect and clean condensate drain pan to avoid clogging of drainage by dirt, dust, etc. Inspect drainage piping to ensure the proper condensate flow.
2. Check and clean the coil. Clean the coils with low pressure water jet or low pressure air.
3. Clean and tighten all the wiring connections.
4. Drain out the system water and check for buildup of mineral deposits.

C.3. Filter Cleaning

1. Remove the filter from the bottom or side.
2. Clean the filter with a brush, or with water.
3. Slide back the filter into the rack.

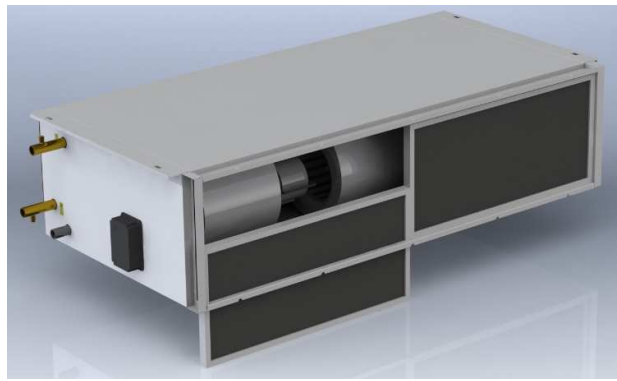
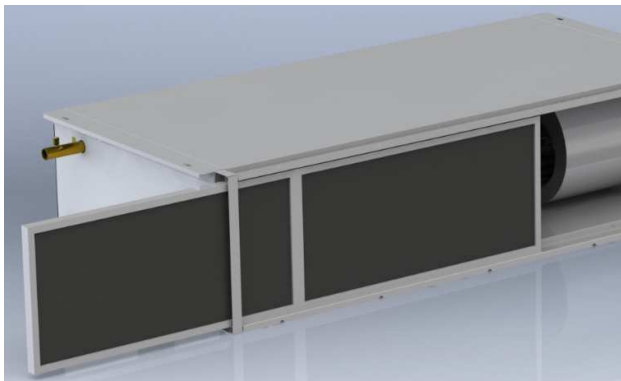

C.4. Coil and Fan Motor Assembly Maintenance

1. Remove the screws from the both sides, then take out the bottom panel. Be care of the bottom panel falling down when removing the screws.
2. Remove the screws on the both side, then pull out the fan deck assembly from the unit body.

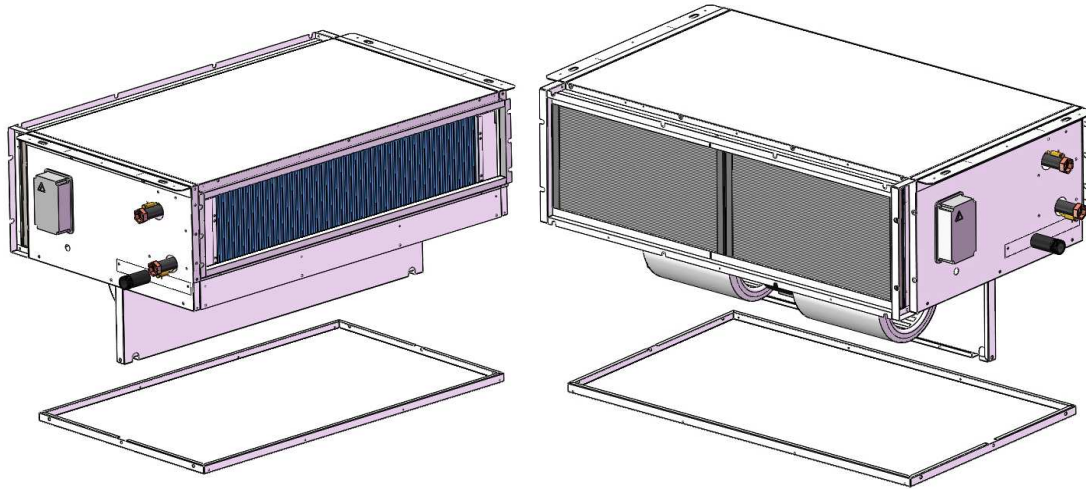

C.5. EH Installation and Maintenance

1. EH kit is a optional part, which can be installed on the supply(discharge) air side. (supply = discharge meaning)
2. Remove the unit's discharge flange and install the EH kit on the unit.
3. Install discharge flange on the EH kit.
4. Connect wires according to unit's wiring diagram.
5. EH element can be slide out from side for maintenance.

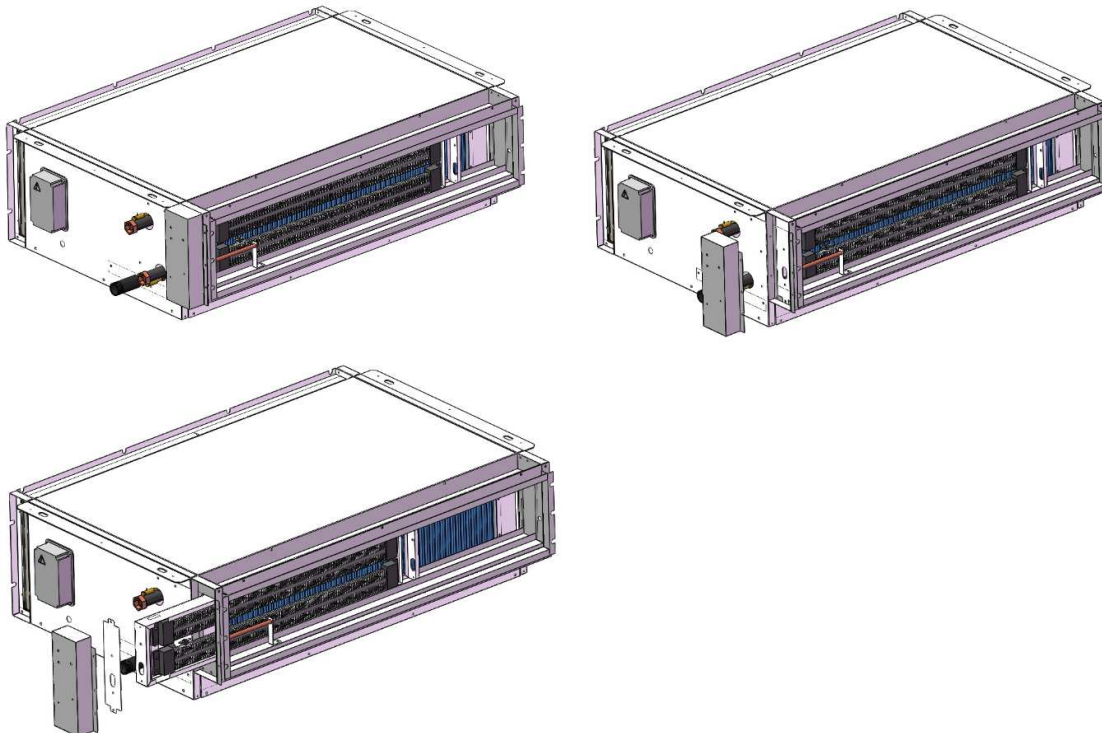

D. Control Specifications: Intelligent Control (I TYPE)

D.1. I/O Port Definitions for I TYPE

I/O		Code	Description
Analogue Input	Return air sensor	AI1	Return air temperature (Tr)
	Sensor 2	AI2	Water inlet temperature sensor (Ti1)
	Sensor 1	AI3	Water outlet temperature sensor (Ti2)
Input	LED display / IR receiver	X-DIS 1	Digital communication port to LED display / IR receiver board.
	Wired wall pad	TTL1	Digital communication port to wired wall-pad board.
Digital input	Occupancy contact	ON/OFF	NO/NC contact by setting
	Float switch	Float	Voltage-free (NC). The contact is for float switch (NC);
	Electric Heater safety switch	EH	Voltage-free (NC). The contact for E-heater safeties.
Power input	Live	L1	Power supply
	Neutral	N1	
	Earth	PE1	
Voltage output	Fan 1	CN4	Fan 1 driver
	Fan2	CN5	Fan 2 driver
	Valve1	MTV1	On/off valve
	Valve2	MTV2	On/off valve
	Water pump	WP	Voltage output (L), Power supply to condensate pump.
	Voltage of Electric Heater (Live)	L-EH	Voltage output (L), maximum 30A.
	Stepping motor	CN1-2	Power supply to louver stepping motors.
output	Cooling signal contact.	AUX1	Voltage free contact. Maximum load 5A.
	Heating signal contact.	AUX2	Voltage free contact. Maximum load 5A.
	24VAC power input	DA1	24VAC external power supply (modulating valve applications only).
	Modulating valve control	DA2	0~10Vdc
	Modulating valve control	DA3	0~10Vdc
	In Modbus signal	AB	Modbus port
	Out Modbus signal	AB	

D.2. Wiring Diagram for I Type

Wiring Diagram for PDWD-400/800-EC

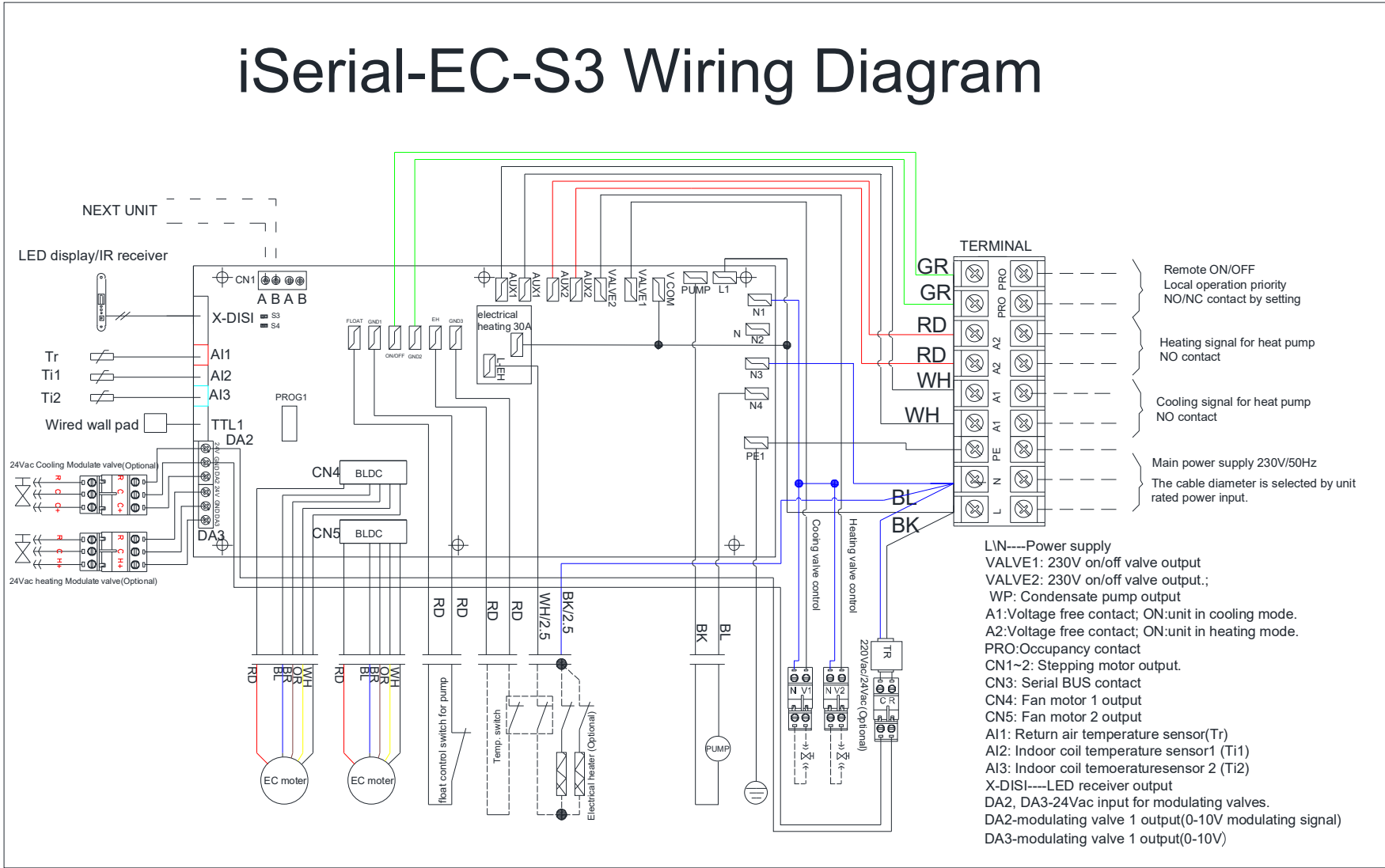

iSerial-EC-W4+S8 Wiring Diagram

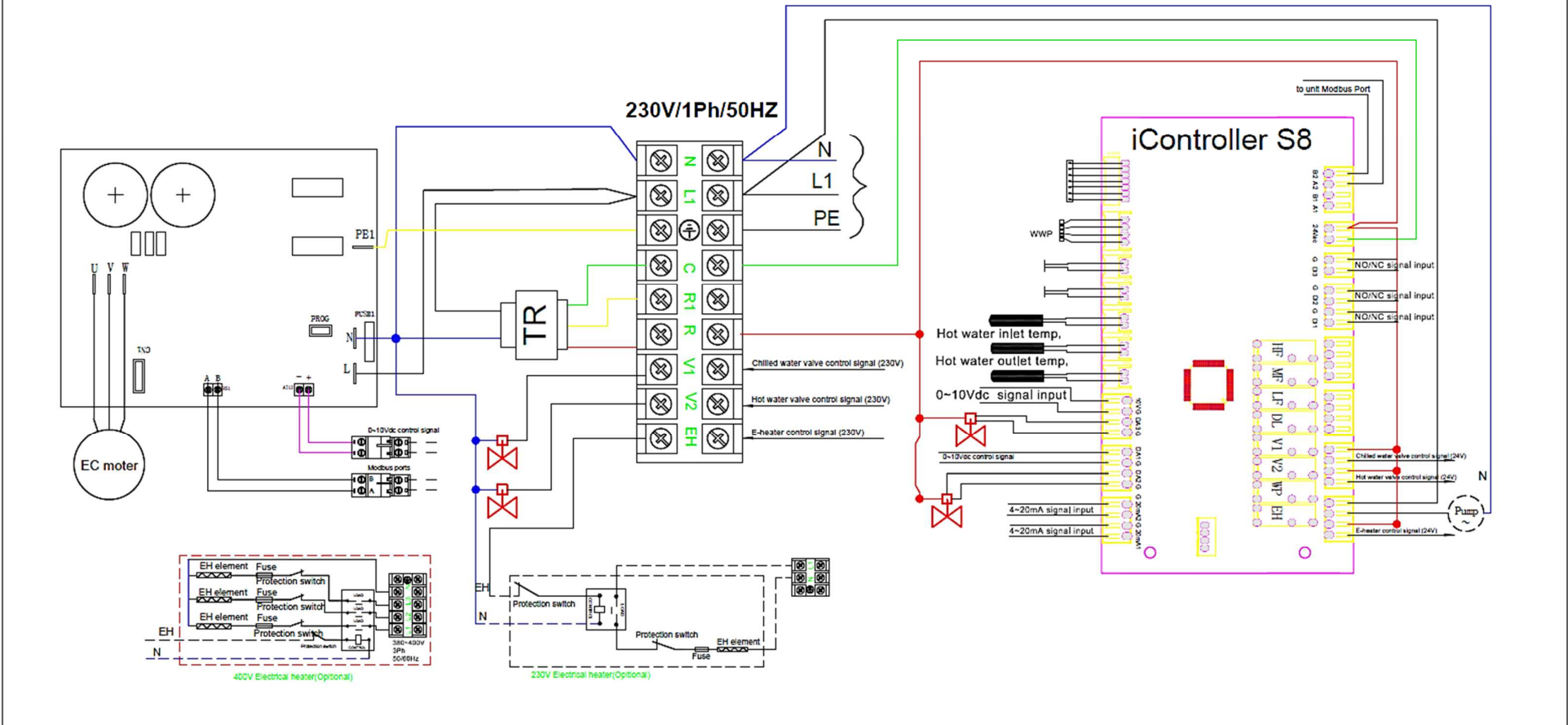

iSerial-EC-W5+S8 Wiring Diagram

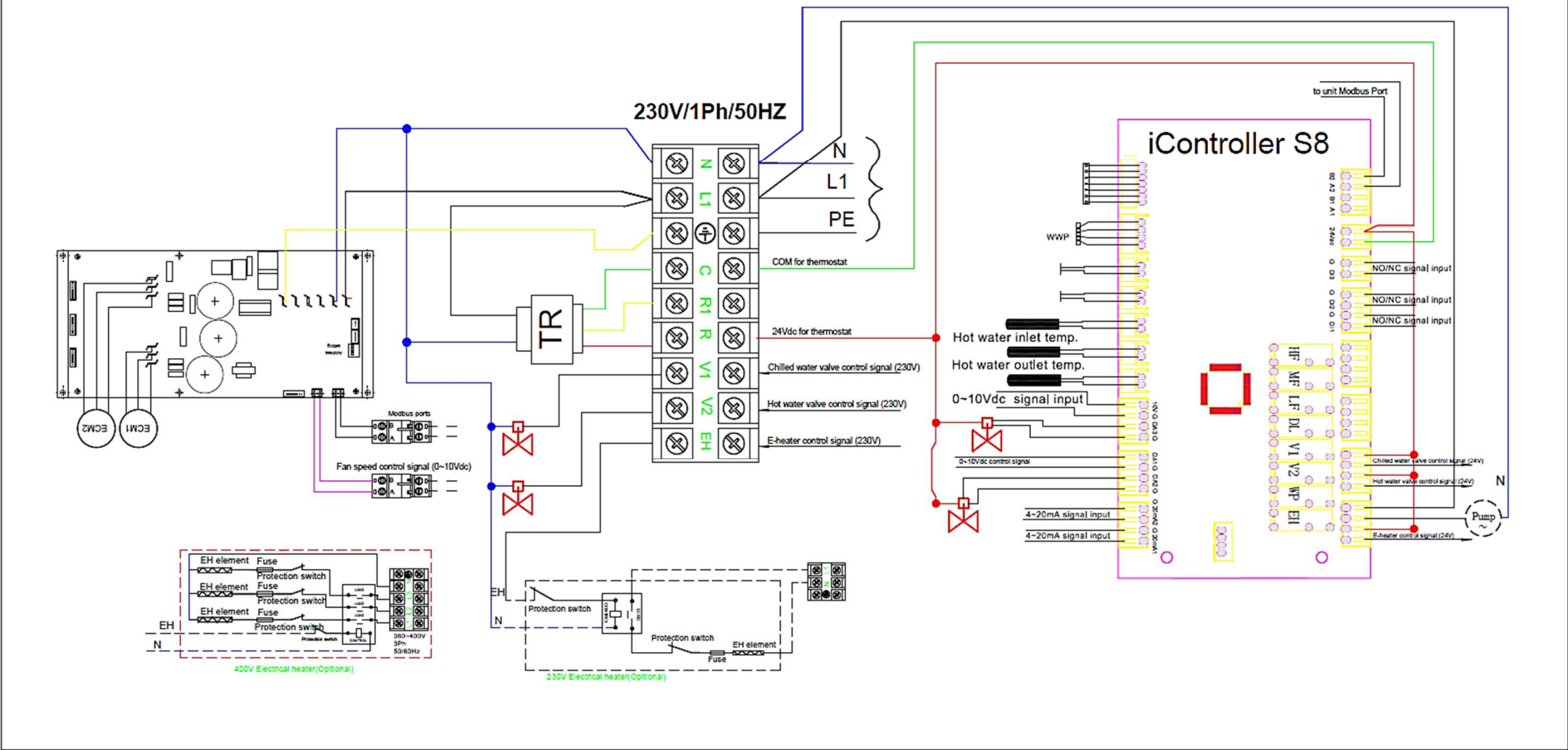

D.3. Control Logic for I control

D.3.1. Control Logics for I Control for EC-S3 (300029=1)

For 2-pipe with Valve Configuration For EC-S3 (300046=0)

COOL MODE

When unit is turned on in cooling mode:

a) If $T_r \geq T_s + 1^\circ\text{C}$ (Modbus 300033 setting), MTV1 is turned on. AUX1 is closed. Fan is turned on at setting speed.

DA2 is turned on at 10VDC for 2 minutes, then check Ti1:

When $T_{i1} \leq 8^\circ\text{C}$, DA2 output is based on water temperature difference (T_{i1}/T_{i2}) and Modbus parameter 300027 setting PID calculation. The output is the minimum output (Modbus300015 setting) -10VDC.

When $8 < T_{i1} \leq 10^\circ\text{C}$, DA2 output is based on water temperature difference (T_{i1}/T_{i2}) and Modbus parameter 300027 setting minus 1 PID calculation. The output is minimum output (Modbus300015 setting) -10VDC.

When $10 < T_{i1} \leq 12^\circ\text{C}$, DA2 output is based on water temperature difference (T_{i1}/T_{i2}) and Modbus parameter 300027 setting minus 2 PID calculation. The output is minimum output (Modbus300015 setting) -10VDC.

When $12 < T_{i1} \leq 15^\circ\text{C}$, DA2 output is based on water temperature difference (T_{i1}/T_{i2}) and Modbus parameter 300027 setting minus 3 PID calculation. The output is minimum output (Modbus300015 setting) -10VDC.

When $15 < T_{i1} \leq 28^\circ\text{C}$ (Modbus 300017 setting), DA2 output is kept at 10VDC.

When $T_{i1} > 28^\circ\text{C}$ (Modbus 300017 setting), DA2 output is at minimum (Modbus300016 setting). and report pre-heat alarm.

b) If $T_r < T_s - 1^\circ\text{C}$ (Modbus 300033 setting), then cool operation is terminated and MTV1 and AUX1 are turned off. Indoor fan runs at set speed. DA2 output is 0VDC.

c) When unit is turned off, MTV1 and AUX1 are off. DA2 is 0VDC. Fan is turned off after 30s.

d) The range of T_s is 16 - 30°C.

e) Indoor fan speed can be adjusted to low, medium, high and auto.

LOW TEMPERATURE PROTECTION OF INDOOR COIL IN COOLING MODE

If $T_{i1} \leq 2^\circ\text{C}$ for 2 minutes, MTV1 is turned OFF. DA2 is 0VDC. Indoor fan is set at Medium speed if fan runs at low speed.

If $T_{i1} \geq 5^\circ\text{C}$ for 2 minutes, MTV1 is turned ON. DA2 is set to original status. Indoor fan is changed to set speed.

FAN MODE

Indoor fan speed can be adjusted to low, medium and high. If fan speed is set to auto by Modbus, fan will run at low speed.

HEAT MODE

Without Electrical Heater (Modbus300047=0)

a) When unit is turned on in heating mode:

When $T_r \leq T_s - 1^\circ\text{C}$ (Modbus 300033 setting), MTV1 and AUX2 are turned on. DA2 is at 10VDC for 2 minutes, check Ti1:

If $T_{i1} < 28^\circ\text{C}$ (Modbus 300017 setting), fan is turned on at low speed. DA2 is at 10VDC.

If $28^\circ\text{C} < T_{i1} < 28(\text{Modbus 300017 setting}) + 4^\circ\text{C}$, fan is on at original state. DA2 is at original state.

If $T_{i1} \geq 28(\text{Modbus 300017 setting}) + 4^\circ\text{C}$, fan is on at setting speed. DA2 output is based on water temperature difference (T_{i1}/T_{i2}) and Modbus parameter 300027 setting PID calculation. The output is minimum output (Modbus300015 setting) - 10VDC. If Ti1 sensor is damaged, fan will run at setting speed.

b) When $T_r > T_s + 1^\circ\text{C}$ (Modbus 300033 setting), MTV1 and AUX2 are turned off. DA2 is at 0VDC. fan will run at lowest speed.

c) When unit is turned off, MTV1 and AUX2 are turned off. DA2 is at 0VDC. Fan is turned off after 2 minutes.

With Electrical Heater as booster (Modbus300047=1)

a) When unit is turned on in heating mode:

When $T_r \leq T_s - 1^\circ\text{C}$ (Modbus 300033 setting), MTV1 and AUX2 are turned on. Fan is turned on at setting speed. DA2 is at 10VDC for 2 minutes, then check Ti1:

If $T_{i1} < 28^\circ\text{C}$ (Modbus 300017 setting), EH is turned on. DA2 is at 10VDC.

If $28^\circ\text{C} < T_{i1} < 28(\text{Modbus 300017 setting}) + 4^\circ\text{C}$, EH is kept at original state. DA2 is at original state.

If $T_{i1} \geq 28(\text{Modbus 300017 setting}) + 4^\circ\text{C}$, EH is turned off. DA2 output is based on water temperature difference (T_{i1}/T_{i2}) and Modbus parameter 300027 setting PID calculation. The output is minimum output (Modbus300015 setting) -10VDC.

If Ti1 sensor is damaged, fan will run at set speed.

b) When $T_r > T_s + 1^\circ\text{C}$ (Modbus 300033 setting), MTV1 and AUX2 are turned off. EH is turned off. DA2 is at 0VDC. fan is turned on at low speed.

c) When unit is turned off, MTV1 and AUX2 are turned off. DA2 is at 0VDC. Fan is turned off after 2 minutes.

With Electrical Heater as primary heat source (Modbus300047=2)

When unit is turned on in heating mode: When $T_{i2} \leq 35^\circ\text{C}$ (or T_{i2} is broken) and $T_r \leq T_s - 1^\circ\text{C}$ (Modbus 300033 setting), Fan is turned on at setting speed, EH is turned on. When $T_r > T_s + 1^\circ\text{C}$ (Modbus 300033 setting), EH is turned off. Fan is turned on at low speed.

When unit is turned off, EH is turned off. Fan is turned off after 2 minutes.

OVER-HEAT PROTECTION OF INDOOR COIL

If $Ti1 \geq 75^{\circ}\text{C}$, then MTV1, AUX2, DA2 and EH are turned off. Indoor fan remains on and runs at high speed.

If $Ti1 < 70^{\circ}\text{C}$, then unit keep original state.

If the indoor coil temperature sensor is damaged or not connected, the protection mode will be overridden and the unit will work according to the pre-heat and post-heat program.

DEHUMIDIFICATION MODE

When unit is turned on in dehumidification mode:

AUX1 is turned on. T_s is 24°C .

If $Tr \geq 25^{\circ}\text{C}$ for 30S, then MTV1 will be on for 3 minutes, and then off for 4 minutes. DA2 is on at 3 times of (Modbus 300016 setting). Fan is turned on at low speed.

If $16^{\circ}\text{C} \leq Tr < 25^{\circ}\text{C}$ for 30S, then MTV1 will be on for 3 minutes, and then off for 6 minutes. DA2 is on at double of (Modbus 300016 setting). Fan is turned on at low speed.

If $Tr < 16^{\circ}\text{C}$ for 30S, then MTV1 will be on for 3 minutes, and then off for 10 minutes. DA2 is on at (Modbus 300016 setting). Fan is turned on at low speed.

At the end of the above dehumidification cycle, the system will decide the next dehumidification control option.

AUTO MODE

When unit is turned on in Auto mode, fan is turned on at setting speed for 30s, then check Tr and T_s :

If $T_s \geq Tr + 3^{\circ}\text{C}$, the unit runs in heating mode. If $Tr - 3^{\circ}\text{C} < T_s < Tr + 3^{\circ}\text{C}$, the unit runs in fan mode. If $T_s < Tr - 3^{\circ}\text{C}$, the unit runs in cooling mode. If unit working mode is confirmed, the unit will not change the working mode. After the unit is turned off and restart in 2 hours, working mode will be confirmed again.

4-Pipe System with Modulating Valves For EC-S3 (300046=2)

COOL MODE

a) When unit is turned on in cooling mode:

If $Tr \geq T_s + 1^{\circ}\text{C}$ (Modbus 300033 setting), MTV1 is turned on. AUX1 is closed. Fan is turned on at setting speed.

DA2 is turned on at 10VDC for 2 minutes, then check Tr and T_s .

DA2 output is from minimum (Modbus 300016 setting) -10VDC based on Tr and $(T_s + 2)$ PID calculation.

b) If $Tr < T_s - 1^{\circ}\text{C}$ (Modbus 300033 setting), then cool operation is terminated and MTV1 and AUX1 are turned off. Indoor fan runs at set speed. DA2 output is 0VDC.

c) When unit is turned off, MTV1 and AUX1 are off. DA2 is 0VDC. Fan is turned off after 30s.

d) The range of T_s is $16 - 30^{\circ}\text{C}$

e) Indoor fan speed can be adjusted to low, medium, high and auto.

LOW TEMPERATURE PROTECTION OF INDOOR COIL IN COOLING MODE

If $Ti1 \leq 2^{\circ}\text{C}$ for 2 minutes, MTV1 is turned OFF. DA2 is 0VDC. Indoor fan is set at Medium speed if fan runs at low speed.

If $Ti1 \geq 5^{\circ}\text{C}$ for 2 minutes, MTV1 is turned ON. DA2 is set to original status. Indoor fan is changed to set speed.

FAN MODE

Indoor fan speed can be adjusted for low, medium and high. If fan speed is set at auto by Modbus, fan will run at low speed.

HEAT MODE

Without Electrical Heater (Modbus300047=0)

a) When unit is turned on in heating mode:

When $Tr \leq T_s - 1^{\circ}\text{C}$ (Modbus 300033 setting), MTV2 and AUX2 are turned on. DA3 is 10VDC for 2 minutes, check $Ti2$:

If $Ti2 < 28^{\circ}\text{C}$ (Modbus 300017 setting), fan is turned on at low speed. DA3 is at 10VDC.

If $28^{\circ}\text{C} < Ti2 < 28(\text{Modbus 300017 setting}) + 4^{\circ}\text{C}$, fan is on at original state. DA3 is at original state.

If $Ti2 \geq 28(\text{Modbus 300017 setting}) + 4^{\circ}\text{C}$, fan is on at setting speed. DA3 output is from minimum (Modbus 300016 setting) - 10VDC based on Tr and $(T_s - 2)$ PID calculation. If $Ti2$ sensor is damaged, fan will run at setting speed.

b) When $Tr > T_s + 1^{\circ}\text{C}$ (Modbus 300033 setting), MTV2 and AUX2 are turned off. DA3 is at 0VDC. fan runs at lowest speed.

c) When unit is turned off, MTV2 and AUX2 are turned off. DA3 is at 0VDC. Fan is turned off after 2 minutes.

OVER-HEAT PROTECTION OF INDOOR COIL

If $Ti2 \geq 75^{\circ}\text{C}$, then MTV2, AUX2, DA2 and EH are turned off. Indoor fan remains on and runs at high speed.

If $Ti2 < 70^{\circ}\text{C}$, then unit keep original state.

If the indoor coil temperature sensor is damaged or not connected, then the protection mode will be overridden and the unit will work according to the pre-heat and post-heat program.

DEHUMIDIFICATION MODE

When unit is turned on in dehumidification mode:

AUX1 is turned on. Ts is 24 °C.

If $Tr \geq 25^{\circ}\text{C}$ for 30S, then MTV1 will be ON for 3 minutes, and then OFF for 4 minutes. DA2 is on at 3 times of (Modbus 300016 setting). Fan is turned on at low speed.

If $16^{\circ}\text{C} \leq Tr < 25^{\circ}\text{C}$ for 30S, then MTV1 will be ON for 3 minutes, and then OFF for 6 minutes. DA2 is on at double of (Modbus 300016 setting). Fan is turned on at low speed.

If $Tr < 16^{\circ}\text{C}$ for 30S, then MTV1 will be ON for 3 minutes, and then OFF for 10 minutes. DA2 is on at (Modbus 300016 setting). Fan is turned on at low speed.

At the end of the above dehumidification cycle, the system will decide the next dehumidification control option.

AUTO MODE

When unit is turned on in Auto mode, fan is turned on at setting speed for 30S, then check Tr and Ts.

- 1) If $Ts \geq Tr + 3^{\circ}\text{C}$, the unit runs in heating mode.
- 2) If $Tr - 3^{\circ}\text{C} < Ts < Tr + 3^{\circ}\text{C}$, the unit runs in fan mode.
- 3) If $Ts < Tr - 3^{\circ}\text{C}$, the unit runs in cooling mode.
- 4) If unit runs in heating or fan mode, when $Tr - Ts > 3.0^{\circ}\text{C}$, MTV2, MTV1 and DA3 are off for more than 10minutes, EH is off for more than 10 minutes, the unit will work in cooling mode.
- 5) If unit runs in cooling or fan mode, when $Ts - Tr > 3.0^{\circ}\text{C}$, MTV2, MTV1 and DA2 are off for more than 10minutes, the unit will work in heating mode.

2-pipe with 6-way Modulating Valve For EC-S3 (300046=3)**COOL MODE**

a) When unit is turned on in cooling mode:

If $Tr \geq Ts + 1^{\circ}\text{C}$ (Modbus 300033 setting), MTV1 is turned on. AUX1 is closed. Fan is turned on at setting speed. DA2 is turned on at 0VDC for 2 minutes, then check Ti1:

When $Ti1 \leq 8^{\circ}\text{C}$, DA2 output is based on water temperature difference ($Ti1/Ti2$) and Modbus parameter 300027 setting PID calculation. The output is 4-0VDC.

When $8 < Ti1 \leq 10^{\circ}\text{C}$, DA2 output is based on water temperature difference ($Ti1/Ti2$) and Modbus parameter 300027 setting minus 1 PID calculation. The output is 4-0VDC.

When $10 < Ti1 \leq 12^{\circ}\text{C}$, DA2 output is based on water temperature difference ($Ti1/Ti2$) and Modbus parameter 300027 setting minus 2 PID calculation. The output is 4-0VDC.

When $12 < Ti1 \leq 15^{\circ}\text{C}$, DA2 output is based on water temperature difference ($Ti1/Ti2$) and Modbus parameter 300027 setting minus 3 PID calculation. The output is 4-0VDC.

When $15 < Ti1 \leq 28^{\circ}\text{C}$ (Modbus 300017 setting), DA2 output is kept at 0VDC.

When $Ti1 > 28^{\circ}\text{C}$ (Modbus 300017 setting), DA2 output is 4VDC. and report pre-heat alarm.

- b) If $Tr < Ts - 1^{\circ}\text{C}$ (Modbus 300033 setting), then cool operation is terminated and MTV1 and AUX1 are turned off. Indoor fan runs at set speed. DA2 output is 5VDC.
- c) When unit is turned off, MTV1 and AUX1 are off. DA2 is 5VDC. Fan is turned off after 30s.
- d) The range of Ts is 16 - 30°C
- e) Indoor fan speed can be adjusted to low, medium, high and auto.

LOW TEMPERATURE PROTECTION OF INDOOR COIL IN COOLING MODE

If $Ti1 \leq 2^{\circ}\text{C}$ for 2 minutes, MTV1 is turned OFF. DA2 is set to 5Vdc. Indoor fan is turned on at Medium speed if fan runs at low speed. If $Ti1 \geq 5^{\circ}\text{C}$ for 2 minutes, MTV1 is turned ON. DA2 is set to original status. Indoor fan is changed to set speed.

FAN MODE

Indoor fan speed can be adjusted for low, medium and high. If fan speed is set auto by Modbus, fan runs at low speed.

HEAT MODE**Without Electrical Heater (Modbus300047=0)**

a) When unit is turned on in heating mode:

When $Tr \leq Ts - 1^{\circ}\text{C}$ (Modbus 300033 setting), MTV2 and AUX2 are turned on. DA2 is at 10VDC for 2 minutes, then check Ti1:

If $Ti1 < 28^{\circ}\text{C}$ (Modbus 300017 setting), fan is turned on at low speed. DA2 is at 10VDC.

If $28^{\circ}\text{C} < Ti1 < 28(\text{Modbus 300017 setting}) + 4^{\circ}\text{C}$, fan is on at original state. DA2 is at original state.

If $Ti1 \geq 28(\text{Modbus 300017 setting}) + 4^{\circ}\text{C}$, fan is on at setting speed. DA2 output is based on water temperature difference ($Ti1/Ti2$) and Modbus parameter 300027 setting PID calculation. The output is 6-10VDC.

If Ti1 sensor is damaged, fan is worked at setting speed.

- b) When $Tr > Ts - 1^{\circ}\text{C}$ (Modbus 300033 setting), MTV1 and AUX2 are turned off. DA2 is at 5VDC. fan is turned on at lowest speed.
- c) When unit is turned off, MTV1 and AUX2 are turned off. DA2 is at 5VDC. Fan is turned off after 2 minutes.

OVER-HEAT PROTECTION OF INDOOR COIL

If $T_{i1} \geq 75^{\circ}\text{C}$, then MTV1, AUX2, DA2 and EH are turned off. Indoor fan remains on and runs at high speed.

If $T_{i1} < 70^{\circ}\text{C}$, then unit keep original state.

If the indoor coil temperature sensor is damaged or not connected, then the protection mode will be overridden and the unit will work according to the pre-heat and post-heat program.

DEHUMIDIFICATION MODE

When unit is turned on in dehumidification mode:

AUX1 is turned on. T_s is 24°C . If $T_r \geq 25^{\circ}\text{C}$ for 30S, then MTV1 will be ON for 3 minutes, then OFF for 4 minutes. DA2 is 2VDC.

Fan is turned on at low speed. If $16^{\circ}\text{C} \leq T_r < 25^{\circ}\text{C}$ for 30S, then MTV1 will be ON for 3 minutes, and then OFF for 6 minutes. DA2 is 2.5VDC. Fan is turned on at low speed.

If $T_r < 16^{\circ}\text{C}$ for 30S, then MTV1 will be ON for 3 minutes, and then OFF for 10 minutes. DA2 is 3.5VDC. At the end of dehumidification cycle, the system will decide the next dehumidification cycle.

AUTO MODE

When unit is turned on in Auto mode, fan is turned on at setting speed for 30S, then check T_r and T_s .

If $T_s \geq T_r + 3^{\circ}\text{C}$, the unit is worked in heating mode. If $T_r - 3^{\circ}\text{C} < T_s < T_r + 3^{\circ}\text{C}$, the unit is worked in fan mode. If $T_s < T_r - 3^{\circ}\text{C}$, the unit is worked in cooling mode.

If unit works in heating or fan mode, when $T_r - T_s > 3.0^{\circ}\text{C}$, MTV2, MTV1 and DA2 are off for more than 10minutes. EH is off for more than 10 minutes, the unit will work in cooling mode. If unit works in cooling or fan mode, when $T_s - T_r > 3.0^{\circ}\text{C}$, MTV2, MTV1 and DA2 are off for more than 10minutes. the unit will work in heating mode.

FOR 2-PIPE AND 4-PIPE SYSTEMS**PRO (N/O signal input)****When Modbus 100004=0;**

The unit is on:

PRO input is closed for 60S, the unit is turned off.

PRO input is open for 60S, the unit is turned on.

When Modbus 100004=1;

1) The unit is on or standby, PRO input is open or closed, the unit is kept original state;

2) The unit is off,

PRO input is closed for 30S, MTV1 is turned on, DA2 is open at double of minimum setting (Modbus 300027 setting), Fan is turn on at low speed;

PRO input is opened for 30S, MTV1 is off, DA2 is 0VdV, Fan is turn off.

3) In period of PRO closed time, if unit receives instruction from remote handset, wired wall pad or Modbus, the unit will work according to the instruction at once.

SLEEP MODE

SLEEP mode can only be set when the unit is in COOL or HEAT mode.

In COOL mode, after SLEEP mode is set, the indoor fan will run at auto speed and T_s will increase by 0.5°C for every 30mins.

In HEAT mode, after SLEEP mode is set, the indoor fan will run at auto speed and T_s will decrease by 0.5°C for every 30 minutes.

Sleep mode is turned off, the setting temperature resumes and Fan is changed to setting speed.

FAN SPEED

In COOL/HEAT mode, the fan speed cannot be changed until it has run for more than 30 seconds.

BUZZER

The unit will beep once when it receives 1 signal.

AUTO RESTART

The system uses non-volatile memory to save the current operation parameters when system is turned off or in case of system failure or cessation of power supply. When power supply resumes or the system is switched on again, the same operations as previously settings will function.

DRAIN PUMP (IF INSTALLED)

Drain pump is turned ON if the unit is turned on in cooling or dehumidification mode. It remains on for 5 minutes after unit is turned OFF.

During mode change from cooling or dehumidification to heating or fan mode, the pump will be turned off after 5 minutes.

If the system is turned off at the circuit breaker (or main power supply), the drain pump function is off.

FLOAT SWITCH (IF INSTALLED)

If the float switch (N/C) is opened before the unit is turned on and if running at COOL mode, then MTV1 is turned off. The drain pump will be turned on and indoor fan will keep running. After float switch is closed, MTV1 is turned on.

If the unit is turned on in COOL mode and the float switch is opened continuously ≥ 5 seconds, then the drain pump will be turned on and MTV1 will remain off. After the float switch is closed, the drain pump will run for an additional 5 minutes. If the float switch is opened for 10 minutes continuously, then MTV1 will remain off and the indoor fan runs at set speed and the system will report an error signal.

If the unit is off and the float switch is opened, then the drain pump will be turned on. After the float switch is closed, the drain pump will run for an additional 5 minutes. If the float switch is opened for 10 minutes continuously, then the system will report an error signal.

EH PROTECTION SWITCH

Before the electrical heater is turned on, the EH safety switch must be closed, EH is open for 3 minutes and EC motor RPM must be more than MODBUS300020 setting

When electrical heater is ON, electrical heater safety switch is opened for ≥ 1 second or EC motor RPM is lower than Modbus 300020 setting, EH will be turned off immediately and report an error and fan speed is changed to high speed.

Once the contact is returned to the closed ≥ 180 seconds and EC motor RPM must be more than MODBUS300020 setting, reset the error and the heater will start again.

When the EH safety switch is opened ≥ 3 times within 60 minutes the heater is not allowed to start anymore.

Turn off the unit to reset the fault, provided that the switch has returned to the closed position.

LOW TEMPERATURE PROTECTION OF INDOOR COIL IN WINTER

This is frost protection when the unit is off to prevent water from freezing in the coil.

If a 2-pipe system is in Standby Mode, when $Tr \leq 2$ °C for 2 minutes, MTV1 is turned on. AUX2 is on. DA2 is 5VDC. If $Ti1 < 5$ °C for 2 minutes, EH (if installed) is switched on. Indoor fan is turned on at low speed. If $Tr \geq 5$ °C for 2 minutes, MTV2 is turned off. AUX2 is off. DA2 is 0VDC. EH (if installed) is turned off. Indoor fan is switched off.

If a 4-pipe system (or 2-pipe unit with 6-way valve) is in Standby Mode, when $Tr \leq 2$ °C for 2 minutes, MTV2 is turned on. AUX2 is on. DA3 is 5VDC (DA2 is 8VDC if using 6-way valve). If $Ti1 < 5$ °C for 2 minutes EH (if installed) is switched on. Indoor fan is turned on at low speed. If $Tr \geq 5$ °C for 2 minutes, MTV2 is turned off. AUX2 is off. DA3 is 0VDC (DA2 is 5VDC if using 6-way valve). EH (if installed) is turned off. Indoor fan is switched off.

D.3.2. Control Logics for I Control for EC-S8 (300029=2)

2-pipe with modulating valve for EC-S8 (300046=0)

COOL MODE

a) If $Tr \geq Ts + 1$ °C, then cool operation is activated, MTV1 is turned on. Indoor fan runs at set speed.

DA2 is open at 10Vdc for 2 min. Then check $Ti1$,

MS300080=0,

When $Ti1 \leq 8$ °C, DA2 output is based on water temperature difference ($Ti1/Ti2$) and Modbus parameter 300027 setting PID calculation. The output is minimum output (Modbus300015 setting)-10Vdc;

When $8 < Ti1 \leq 10$ °C, DA2 output is based on water temperature difference ($Ti1/Ti2$) and Modbus parameter 300027 setting minus 1 PID calculation. The output is minimum output (Modbus300015 setting)-10Vdc;

When $10 < Ti1 \leq 12$ °C, DA2 output is based on water temperature difference ($Ti1/Ti2$) and Modbus parameter 300027 setting minus 2 PID calculation. The output is minimum output (Modbus300015 setting)-10Vdc;

When $12 < Ti1 \leq 15$ °C, DA2 output is based on water temperature difference ($Ti1/Ti2$) and Modbus parameter 300027 setting minus 3 PID calculation. The output is minimum output (Modbus300015 setting)-10Vdc;

When $15 < Ti1 \leq 28$ °C (Modbus 300017 setting), DA2 output is kept at 10Vdc;

When $Ti1 > 28$ °C (Modbus 300017 setting), DA2 output is at minimum (Modbus300016 setting); and report pre-heat alarm

MS300080=1,

DA2 output is based on cooling water flow reading and setting PID calculation. The output is minimum output (Modbus300015 setting)-10Vdc;

MS300080=2,

DA2 output is based on cooling pressure difference setting (MS300084) and 4-20mA input2 reading (MS400007) PID calculation. The output is minimum output (Modbus300015 setting)-10Vdc;

b) If $Tr < Ts - 1$ °C, then cool operation is terminated and MTV1 is turned off. DA2 is 0VDC. Indoor fan runs at set speed.

c) The range of Ts is 16 - 30 °C or fixed according to Parameter 4 setting.

d) Indoor fan speed can be adjusted for low, medium, high and auto.

LOW TEMPERATURE PROTECTION OF INDOOR COIL

If $Ti1 \leq 2$ °C for 2 minutes, then MTV1 is turned off; DA2=0VDC; If indoor fan is set for low speed, then it will run at medium speed. If it is set at medium or high speed, then it will keep running at the same speed.

If $Ti1 \geq 5$ °C for 2 minutes, then MTV1 is turned on. DA2 is calculated by delta T; Indoor fan runs at set speed.

FAN MODE

Indoor fan runs at the set speed while heater, MTV1, MTV2 are turned off. Indoor fan speed can be adjusted to low, medium and high.

HEAT MODE**Heat mode without electrical heater (300047=0)**

a) If $T_r \leq T_s - 1\text{ }^\circ\text{C}$, then heat operation is activated and MTV1 and MTV2 are turned on. DA2 is open at 10Vdc for 2 min. Then check Ti1,

MS300080=0,

If $T_{i1} \leq 28\text{ }^\circ\text{C}$ (300017 setting), fan is turned on at low speed; DA2 is on at 10VDC;

If $28\text{ }^\circ\text{C}$ (300017 setting) $< T_{i1} < 28\text{ }^\circ\text{C}$ (300017 setting) $+ 4\text{ }^\circ\text{C}$, fan and DA2 are kept original state;

If $T_{i1} \geq 28\text{ }^\circ\text{C}$ (300017 setting) $+ 4\text{ }^\circ\text{C}$, fan runs at set speed. DA2 output is from minimum setting(300016setting) - 10Vdc based on Delta Ti and setting; if Ti sensor is damaged, Fan runs at set speed.

MS300080=1,

DA2 output is based on heating water flow reading and setting PID calculation. The output is minimum output (Modbus300015 setting)-10VDC;

MS300080=2,

DA2 output is based on heating pressure difference setting (MS300085) and 4-20mA input2 reading (MS400007) PID calculation. The output is minimum output (Modbus300015 setting)-10VDC;

b) If $T_r > T_s + 1\text{ }^\circ\text{C}$, then heat operation is terminated and MTV1 is turned off. DA2 is 0VDC. Indoor fan is turned OFF.

c) The range of T_s is 16 - 30 $^\circ\text{C}$ or fixed according to Parameter 4 setting.

d) Indoor fan speed can be adjusted to low, medium, high and auto.

Heat mode with electrical heater as booster(300047=1)

a) If $T_r \leq T_s - 1\text{ }^\circ\text{C}$, then heat operation is activated and MTV1 and MTV2 are turned on. Indoor fan runs at the set speed.

DA3 output is from minimum setting(300016setting) - 10Vdc based on Delta T3/T4 and setting; DA2 is open at 10VDC for 2 min. Then check Ti1;

MS300080=0,

If $T_{i1} \leq 28\text{ }^\circ\text{C}$ (300017 setting), EH is closed; DA2 output is 10Vdc; DA3 output is from 0 - 10Vdc based on Delta Ti3/Ti4 and setting;

If $28\text{ }^\circ\text{C}$ (300017 setting) $< T_{i1} \leq 28\text{ }^\circ\text{C}$ (300017 setting) $+ 4\text{ }^\circ\text{C}$, EH and DA2 output are kept original state;

If $T_{i1} > 28\text{ }^\circ\text{C}$ (300017 setting) $+ 4\text{ }^\circ\text{C}$, EH is opened; DA3 is 0Vdc; DA2 output is from minimum setting(300016setting) - 10Vdc based on Delta Ti1/Ti2 and setting;

MS300080=1

DA2 output is based on heating water flow reading and setting PID calculation. The output is minimum output (Modbus300015 setting)-10VDC;

If $T_{i1} \leq 28\text{ }^\circ\text{C}$ (300017 setting), EH is closed;

If $28\text{ }^\circ\text{C}$ (300017 setting) $< T_{i1} \leq 28\text{ }^\circ\text{C}$ (300017 setting) $+ 4\text{ }^\circ\text{C}$, EH is kept original state;

If $T_{i1} > 28\text{ }^\circ\text{C}$ (300017 setting) $+ 4\text{ }^\circ\text{C}$, EH is opened;

MS300080=2

DA2 output is based on heating pressure difference setting (MS300085) and 4-20mA input2 reading (MS400007) PID calculation. The output is minimum output (Modbus300015 setting)-10VDC;

If $T_{i1} \leq 28\text{ }^\circ\text{C}$ (300017 setting), EH is closed;

If $28\text{ }^\circ\text{C}$ (300017 setting) $< T_{i1} \leq 28\text{ }^\circ\text{C}$ (300017 setting) $+ 4\text{ }^\circ\text{C}$, EH is kept original state;

If $T_{i1} > 28\text{ }^\circ\text{C}$ (300017 setting) $+ 4\text{ }^\circ\text{C}$, EH is opened;

b) If $T_r > T_s + 1\text{ }^\circ\text{C}$, then heat operation is terminated and MTV1 and MTV2 are turned off. DA2 is 0VDC. Indoor fan runs at auto speed;

c) The range of T_s is 16 - 30 $^\circ\text{C}$ or fixed according to Parameter 4 setting;

d) Indoor fan speed can be adjusted for low, medium, high and auto.

Heat mode with electrical heater as primary heat source (300047=2)

a) If $T_{i2} \leq 35\text{ }^\circ\text{C}$ (or Ti2 is damaged or disconnected), and if $T_r \leq T_s - 1\text{ }^\circ\text{C}$ (or $-4\text{ }^\circ\text{C}$ if economy contact is closed), heat operation is activated, Indoor fan runs at set speed. EH is turned on. DA3 output is from minimum setting(300016setting) - 10Vdc based on Delta T3 /T4 and setting;

b) If $T_r > T_s + 1\text{ }^\circ\text{C}$ then heat operation is terminated, Electrical heater is OFF. Indoor fan is turn OFF after 120S.

c) The range of T_s is 16-30 $^\circ\text{C}$ or fixed according to Parameter 4 setting.

d) Indoor fan speed can be adjusted for low, medium, high and auto.

OVER-HEAT PROTECTION OF INDOOR COIL IN HEAT MODE

If $T_{i1} \geq 75\text{ }^\circ\text{C}$, then MTV1, DA2, MTV2 and EH are turned off, indoor fan runs at high speed, even in standby mode.

If $T_{i1} < 70\text{ }^\circ\text{C}$, then unit will maintain its original state.

If Ti1 temperature sensor is damaged, the protection mode will be override.

DEHUMIDIFICATION MODE

Ts=24°C;

If Tr ≥ 25°C for 30S, then MTV1 will be ON for 3 minutes, and then OFF for 4 minutes. DA2 is turned on 3times of minimum opening. Fan is running at auto speed.

If 16°C ≤ Tr < 25°C, then MTV1 will be ON for 3 minutes, and then OFF for 6 minutes. DA2 is turned on 2 times of minimum opening. Fan is running at auto speed.

If Tr < 16°C, then MTV1 will be turned ON for 4 minutes and then OFF for 10 minutes. DA2 is turned on minimum opening. Fan is running at auto speed.

AUTOMODE

Fan is turned on at medium speed. Check Tr and Ts in 30S;

if Ts>Tr+3°C for 30S, the unit is turned on in heat mode;

if Tr-3 °C<Ts<Tr+3 °C for 30S, the unit is turned on in fan mode;

If Ts<Tr-3 °C, , the unit is turned on in cool mode;

If the unit working mode is confirmed, it can not change. After unit is turned OFF for 2 hour, then working mode is reset again.

4-pipe with modulating valve for EC-S8 (300046=1)

COOL MODE

a) If Tr ≥ Ts +1 °C, then cool operation is activated, MTV1 is turned on. Indoor fan runs at set speed. DA2 is open at 10Vdc for 2 min. Then check Ti1,

MS300080=0,

When Ti1≤8°C, DA2 output is based on water temperature difference (Ti1/Ti2) and Modbus parameter 300027 setting PID calculation. The output is minimum output (Modbus300015 setting)-10Vdc;

When 8<Ti1≤10°C, DA2 output is based on water temperature difference (Ti1/Ti2) and Modbus parameter 300027 setting minus 1 PID calculation. The output is minimum output (Modbus300015 setting)-10Vdc;

When 10<Ti1≤12°C, DA2 output is based on water temperature difference (Ti1/Ti2) and Modbus parameter 300027 setting minus 2 PID calculation. The output is minimum output (Modbus300015 setting)-10Vdc;

When 12<Ti1≤15°C, DA2 output is based on water temperature difference (Ti1/Ti2) and Modbus parameter 300027 setting minus 3 PID calculation. The output is minimum output (Modbus300015 setting)-10Vdc;

When 15<Ti1≤28°C (Modbus 300017 setting), DA2 output is kept at 10Vdc;

When Ti1>28°C (Modbus 300017 setting), DA2 output is at minimum (Modbus300016 setting); and report pre-heat alarm;

MS300080=1

DA2 output is based on cooling water flow reading and setting PID calculation. The output is minimum output (Modbus300015 setting)-10Vdc;

MS300080=2

DA2 output is based on cooling pressure difference setting (MS300084) and 4-20mA input2 reading (MS400007) PID calculation. The output is minimum output (Modbus300015 setting)-10Vdc;

b) If Tr < Ts-1°C, then cool operation is terminated and MTV1 and AUX1 are turned off. DA2 is 0VDC. Indoor fan runs at set speed.

c) The range of Ts is 16 - 30 °C.

d) Indoor fan speed can be adjusted for low, medium, high and auto.

LOW TEMPERATURE PROTECTION OF INDOOR COIL

If Ti1 ≤ 2 °C for 2 minutes, then MTV1 is turned off. DA2=0VDC. If indoor fan is set for low speed, then it will run at medium speed. If it is set at medium or high speed, then it will keep running at the same speed.

If Ti1 ≥ 5°C for 2 minutes, then MTV1 is turned on. DA2 is calculated by delta T. Indoor fan runs at set speed.

FAN MODE

Indoor fan runs at the set speed while heater, MTV1, MTV2, AUX1 and AUX1 are turned off. Indoor fan speed can be adjusted to low, medium and high.

HEAT MODE

Heat mode without electrical heater (300047=0)

a) If Tr ≤ Ts - 1 °C, then heat operation is activated and MTV2 is turned on.

DA3 is open at 10Vdc for 2 min. Then check Ti3,

MS300080=0,

If Ti3≤28°C (300017 setting), fan is turned on at low speed; DA3 is on at 10VDC;

If 28°C (300017 setting)<Ti3<28(300017 setting) +4°C, fan and DA3 are kept original state;

If $Ti3 \geq 28(300017 \text{ setting}) + 4^{\circ}\text{C}$, fan runs at set speed. DA3 output is from minimum setting(300016setting) - 10Vdc based on Delta T3 and T4 and setting; if Ti1 sensor is damaged, Fan runs at set speed.

MS300080=1

DA3 output is based on heating water flow reading and setting PID calculation. The output is minimum output (Modbus300015 setting)-10VDC;

MS300080=2

DA3 output is based on heating pressure difference setting (MS300085) and 4-20mA input 3 reading (MS400008) PID calculation. The output is minimum output (Modbus300015 setting)-10VDC;

- b) If $Tr > Ts + 1^{\circ}\text{C}$ then heat operation is terminated and MTV2 is turned off. DA3 is 0VDC. Indoor fan is turned on low speed;
- c) The range of Ts is 16 - 30°C.
- d) Indoor fan speed can be adjusted to low, medium, high and auto.

OVER-HEAT PROTECTION OF INDOOR COIL IN HEAT MODE

If $Ti3 \geq 75^{\circ}\text{C}$, then MTV2, DA3, AUX2 and EH are turned off, indoor fan runs at high speed, even in standby mode.

If $Ti3 < 70^{\circ}\text{C}$, then unit will maintain its original state.

If $Ti3$ temperature sensor is damaged, the protection mode will be overridden

DEHUMIDIFICATION MODE

$Ts = 24^{\circ}\text{C}$;

If $Tr \geq 25^{\circ}\text{C}$ for 30S, then MTV1 will be ON for 3 minutes, and then OFF for 4 minutes. DA2 is turned on 3times of minimum opening. Fan is running at auto speed.

If $16^{\circ}\text{C} \leq Tr < 25^{\circ}\text{C}$, then MTV1 will be ON for 3 minutes, and then OFF for 6 minutes. DA2 is turned on 2 times of minimum opening. Fan is running at auto speed.

If $Tr < 16^{\circ}\text{C}$, then MTV1 will be turned ON for 4 minutes and then OFF for 10 minutes. DA2 is turned on minimum opening. Fan is running at auto speed.

AUTOMODE

Fan is turned on at medium speed. Check Tr and Ts in 30S;

if $Ts > Tr + 3^{\circ}\text{C}$ for 30S, the unit is turned on in heat mode;

if $Tr - 3^{\circ}\text{C} < Ts < Tr + 3^{\circ}\text{C}$ for 30S, the unit is turned on in fan mode;

If $Ts < Tr - 3^{\circ}\text{C}$, the unit is turned on in cool mode;

If unit is working at heat mode or Fan mode, if $Tr - Ts > 3.0^{\circ}\text{C}$, MTV2, MTV1 and DA3 are OFF more than 3 minutes, working mode will be changed to cooling mode;

If unit is working at cool mode or Fan mode, if $Ts - Tr > 3.0^{\circ}\text{C}$, MTV2, MTV1 and DA2 are OFF more than 3 minutes, working mode will be changed to heating mode;

2-pipe with 6-way valve unit for EC-S8 (300046=2)

COOL MODE

- a) If $Tr \geq Ts + 1^{\circ}\text{C}$, then cool operation is activated, MTV1 is turned on. Indoor fan runs at set speed.

DA2 is open at 0Vdc for 2 min. Then check $Ti1$,

MS300080=0,

When $Ti1 \leq 8^{\circ}\text{C}$, DA2 output is based on water temperature difference ($Ti1/Ti2$) and Modbus parameter 300027 setting PID calculation. The output is 4-0VDC;

When $8 < Ti1 \leq 10^{\circ}\text{C}$, DA2 output is based on water temperature difference ($Ti1/Ti2$) and Modbus parameter 300027 setting minus 1 PID calculation. The output is 4-0VDC;

When $10 < Ti1 \leq 12^{\circ}\text{C}$, DA2 output is based on water temperature difference ($Ti1/Ti2$) and Modbus parameter 300027 setting minus 2 PID calculation. The output is 4-0VDC;

When $12 < Ti1 \leq 15^{\circ}\text{C}$, DA2 output is based on water temperature difference ($Ti1/Ti2$) and Modbus parameter 300027 setting minus 3 PID calculation. The output is 4-0VDC;

When $15 < Ti1 \leq 28^{\circ}\text{C}$ (Modbus 300017 setting), DA2 output is kept at 0Vdc;

When $Ti1 > 28^{\circ}\text{C}$ (Modbus 300017 setting), DA2 output is 4Vdc; and report pre-heat alarm;

MS300080=1

DA2 output is based on cooling water flow reading and setting PID calculation. The output is minimum output The output is 4-0VDC;

MS300080=2

DA2 output is based on cooling pressure difference setting (MS300084) and 4-20mA input2 reading (MS400007) PID calculation. The output is 4-0VDC.

- b) If $Tr < Ts - 1^{\circ}\text{C}$, then cool operation is terminated and MTV1 is turned off. DA2 is 5VDC. Indoor fan runs at set speed.
- c) The range of Ts is 16 - 30 °C .
- d) Indoor fan speed can be adjusted for low, medium, high and auto.

LOW TEMPERATURE PROTECTION OF INDOOR COIL

If $Ti1 \leq 2 \text{ }^{\circ}\text{C}$ for 2 minutes, then MTV1 is turned off. DA2=5VDC; If indoor fan is set for low speed, then it will run at medium speed. If it is set at medium or high speed, then it will keep running at the same speed.

If $Ti1 \geq 5^{\circ}\text{C}$ for 2 minutes, then MTV1 is turned on. DA2 is calculated by Delta T; Indoor fan runs at set speed.

FAN MODE

Indoor fan runs at the set speed while heater, MTV1, MTV2 are turned off. Indoor fan speed can be adjusted to low, medium and high.

HEAT MODE**Heat mode without electrical heater (300047=0)**

a) If $Tr \leq Ts - 1 \text{ }^{\circ}\text{C}$, then heat operation is activated and MTV2 is turned on. DA2 is open at 10Vdc for 2 min. Then check Ti1.

MS300080=0,

If $Ti1 \leq 28^{\circ}\text{C}$ (300017 setting), fan is turned on at low speed; DA2 is on at 10VDC;

If 28°C (300017 setting) $< Ti1 < 28(300017 \text{ setting}) + 4^{\circ}\text{C}$, fan and DA2 are kept original state;

If $Ti1 \geq 28(300017 \text{ setting}) + 4^{\circ}\text{C}$, fan runs at set speed. DA2 output is from 6 - 10Vdc based on Delta $Ti1/Ti2$ and setting; if Ti sensor is damaged, Fan runs at set speed.

MS300080=1

DA2 output is based on heating water flow reading and setting PID calculation. The output is from 6-10VDC;

MS300080=2

DA2 output is based on heating pressure difference setting (MS300085) and 4-20mA input2 reading (MS400007) PID calculation. The output is from 6-10VDC;

b) If $Tr > Ts + 1 \text{ }^{\circ}\text{C}$, then heat operation is terminated and MTV1 is turned off. DA2 is 5VDC. Indoor fan is turned OFF.

c) The range of Ts is 16 - 30 $^{\circ}\text{C}$.

d) Indoor fan speed can be adjusted to low, medium, high and auto.

DEHUMIDIFICATION MODE

MTV1 is turned on; $Ts = 24^{\circ}\text{C}$;

If $Tr \geq 25^{\circ}\text{C}$ for 30S, DA2 is 1.5Vdc. Fan is running at auto speed.

If $16^{\circ}\text{C} \leq Tr < 25^{\circ}\text{C}$, DA2 is 2.5Vdc. Fan is running at auto speed.

If $Tr < 16^{\circ}\text{C}$, DA2 is 3.5Vdc. Fan is running at auto speed.

AUTOMODE

Fan is turned on at medium speed. Check Tr and Ts in 30S;

if $Ts > Tr + 3^{\circ}\text{C}$ for 30S, the unit is turned on in heat mode;

if $Tr - 3 \text{ }^{\circ}\text{C} < Ts < Tr + 3 \text{ }^{\circ}\text{C}$ for 30S, the unit is turned on in fan mode;

If $Ts < Tr - 3 \text{ }^{\circ}\text{C}$, , the unit is turned on in cool mode;

If the unit working mode is confirmed, it cannot change.

FOR 2-PIPE AND 4-PIPE SYSTEMS**PRO (N/O signal input)****When Modbus 100004=0;**

The unit is on:

PRO input is closed for 60S, the unit is turned off.

PRO input is open for 60S, the unit is turned on.

When Modbus 100004=1;

The unit is on or standby, PRO input is open or closed, the unit is kept original state;

The unit is off, PRO input is closed for 30S, MTV1 is turned on, DA2 is open at double of minimum setting (Modbus 300027 setting), Fan is turn on at low speed;

PRO input is opened for 30S, MTV1 is off, DA2 is 0Vdc, Fan is turn off.

In period of PRO closed time, if unit receives instruction from remote handset, wired wall pad or Modbus, the unit will work according to the instruction at once.

SLEEP MODE

SLEEP mode can only be set when the unit is in COOL or HEAT mode.

In COOL mode, after SLEEP mode is set, the indoor fan will run at auto speed and Ts will increase by 0.5 $^{\circ}\text{C}$ for every 30mins.

In HEAT mode, after SLEEP mode is set, the indoor fan will run at auto speed and Ts will decrease by 0.5 $^{\circ}\text{C}$ for every 30 minutes.

Sleep mode is turned off, the setting temperature resumes and Fan is changed to setting speed.

DA1 0-10vdc control signals

DA1 output is set by 300022 when fan is set at high speed

DA1 output is set by 300021 when fan is set at medium speed;

DA1 output is set by 300020 when fan is set at low speed;

When fan is set auto mode, if 300048=0, DA1 output is calculated by Tr/Ts PID calculation. If 300048=1, DA1 output is calculated by ESP PID calculation.

DRAIN PUMP (IF INSTALLED)

In cooling mode, if MTV1 is turned ON, WP is turned ON. If MTV1 is turned OFF or unit working mode is changed, WP will be turned OFF after 5 minutes.

If the system is turned off at the circuit breaker (or main power supply), the drain pump function is off.

FLOAT SWITCH (IF INSTALLED)

If the float switch (N/C) is opened before the unit is turned on and if running at COOL mode, then MTV1 is turned off. The drain pump will be turned on and indoor fan will keep running. After float switch is closed, MTV1 is turned on.

If the unit is turned on in COOL mode and the float switch is opened continuously ≥ 5 seconds, then the drain pump will be turned on and MTV1 will remain off. After the float switch is closed, the drain pump will run for an additional 5 minutes. If the float switch is opened for 10 minutes continuously, then MTV1 will remain off and the indoor fan runs at set speed and the system will report an error signal.

If the unit is off and the float switch is opened, then the drain pump will be turned on. After the float switch is closed, the drain pump will run for an additional 5 minutes. If the float switch is opened for 10 minutes continuously, then the system will report an error signal.

EH PROTECTION SWITCH

1. If EH protection switch is closed for 30s and Fan is ON, then EH is ON.
2. When EH is ON, EH protection is open for 1s, or Fan is OFF, EH will be turned OFF at once and report alarm.
3. When EH protection switch is closed for 180s, EH will be turned ON again.
4. If EH protection switch is opened 3 times in 1 hour, EH will not be turned ON again except main power reset.

LOW TEMPERATURE PROTECTION OF INDOOR COIL IN WINTER

This is frost protection when the unit is off to prevent water from freezing in the coil.

If a 2-pipe system is in Standby Mode, when $Tr \leq 2$ °C for 2 minutes, MTV1 is turned on. AUX2 is on. DA2 is 5VDC. If $Ti1 < 5$ °C for 2 minutes, EH (if installed) is switched on. Indoor fan is turned on at low speed. If $Tr \geq 5$ °C for 2 minutes, MTV2 is turned off. AUX2 is off. DA2 is 0VDC. EH (if installed) is turned off. Indoor fan is switched off.

If a 4-pipe system (or 2-pipe unit with 6-way valve) is in Standby Mode, when $Tr \leq 2$ °C for 2 minutes, MTV2 is turned on. AUX2 is on. DA3 is 5VDC (DA2 is 8VDC if using 6-way valve). If $Ti1 < 5$ °C for 2 minutes EH (if installed) is switched on. Indoor fan is turned on at low speed. If $Tr \geq 5$ °C for 2 minutes, MTV2 is turned off. AUX2 is off. DA3 is 0VDC (DA2 is 5VDC if using 6-way valve). EH (if installed) is turned off. Indoor fan is switched off.

D.4. Open Modbus Protocol for I-control

D.4.1. Open Modbus Protocol for EC-S3

Transfer Mode: RTU BAUD Rate:9600bps, 8 data bit, 1 stop bit, None parity bit

The communications require a delay between reading an answer and sending the next command of 80 ms. All temperature is equal to reading data*10 accuracy: 0.1 degree C.

Supported Functions

Function Code	Function description
01(01H)	Read Coils
02(02H)	Read Discrete Inputs
03(03H)	Read Holding Registers
04(04H)	Read Input Registers
05(05H)	Write Single Coil
06(06H)	Write Single Register
15(0FH)	Write Multiple Coils
16(10H)	Write Multiple Registers
255(FFH)	Extended Commands which are used to test.

Valid Error code table:

Error code	description	definition
01 (01H)	Invalid commands	Received commands beyond valid commands
02 (02H)	Invalid data address	Data addresses beyond valid data address
03 (03H)	Invalid data	Data beyond definition range
04 (04H)	Write data not succeed	Write data not succeed

Coils table:

Description	Address	Type*	Remark
ON/OFF	100000	R/W	
Sleeping mode	100001	R/W	
Louver swings	100002	R/W	
Energy Saving Mode	100003	R/W	
PRO function	100004	R/W	

Discrete table:

Description	Address	Type*	Remark
MTV1	200000	R	
MTV2	200001	R	
AUX1	200002	R	
AUX2	200003	R	
Condensate pump	200004	R	
Electrical heater	200005	R	
Wired wall pad	200006	R	
PR-O1	200007	R	
Float switch	200008	R	
Reserved	200009	R	
EH safety switch	200010	R	
Internal test	200011	R	Testing purpose only.

* R = read only, W = write only, R/W = read and write.

Holding Register table:

Description	Address	Type*	Remark
Mode setting	300000	R/W	Cooling mode = 01(H) Humidify mode = 02(H) Fan mode = 04(H) Heating mode = 08(H) Auto mode = 10(H)
Fan speed setting	300001	R/W	Low speed = 04(H) Medium speed = 02(H) High speed = 01(H) Auto fan speed = 07(H)
Louver swing setting	300002	R/W	Position 1=01(H)
			Position2=02(H)
			Position3=03(H)
			Position4=04(H)
			Auto=0F(H)
Stop=00(H)			
Setting temperature	300003	R/W	16-30 (actual*10 format)
Address setting	300004	R/W	1-255
Reset	300005	W	=0x33 reset error
Week	300006	W	
Hour	300007	W	
Minute	300008	W	
Second	300009	W	
Hours in Timer on	300010	R/W	Timer ON
Minute in Timer on	300011	R/W	Timer ON
Hours in Timer off	300012	R/W	Timer OFF
Minute in Timer off	300013	R/W	Timer OFF
Icon of Timer ON or OFF	300014	R/W	BIT0 = Icon of Timer ON BIT1 = Icon of Timer OFF 1 = enable 0 = disable
Minimum output DA2	300015	R/W	Default 25% (2.5vdc)
Minimum output DA3	300016	R/W	Default 25% (2.5vdc)
Pre-heat temperature setting	300017	R/W	25-35, default: 30
Reserved-	300018	R/W	
Super low speed rpm	300019	R/W	
Low speed rpm	300020	R/W	
Medium speed rpm	300021	R/W	
High speed rpm	300022	R/W	
Signal output setting	300023	R/W	1-10VDC (used to test, 0 = disable)
Temperature sampling time	300024	R/W	2-100, default: 5S
Factor of auto fan speed	300025	R/W	2-150, default:20
Factor of modulating valve	300026	R/W	2-250, default:150
Ti1 and Ti2 Cooling difference setting	300027	R/W	3-15, default:5
Ti1 and Ti2 Heating difference setting	300028	R/W	3-15 default:5
Controller Hardware type setting	300029	R/W	0=air cleaner (S5) 1=FCU (S1/S2/S3, SWC-S) 2=AHU (S6) or (AHU+W5) 3=AHU+AQI (S5+S6) 4=Zone controller(S7) Setting:1
Degree unit setting	300030	R/W	0=degree C 1=degree F
Temperature display setting	300031	R/W	0=Room temperature display on LED 1=Setting temperature display on LED
Setting temperature range	300032	R/W	0=setting temperature range is from 16-30 1=Setting temperature range is fixed. Cooling=24°C, Heating=21°C

Temperature band setting	300033	R/W	
Reserved	300034	R/W	
Reserved	300035	R/W	
Reserved	300036	R/W	
Reserved	300037	R/W	
Reserved	300038	R/W	
Reserved	300039	R/W	
Reserved	300040	R/W	
Reserved	300041	R/W	
Reserved	300042	R/W	
Reserved	300043	W	
Reserved	300044	W	
Reserved	300045	W	
Software type	300046	R/W	0=2-pipe+MTV 1=2-pipe without valve 2=4-pipe+std valve 3=4-pipe+6-way valve
EH type	300047	R/W	0=without EH, 1=EH as booster; 2=EH as primary
DA1 control signal	300048	R/W	0=Tr/Ts 1=ESP
EC motor input ports	300049	R/W	0=CN4 working 1=CN5 working 2=CN4+CN5 working default:0
PRO1 input type	300050	R/W	0=NO 1=NC
Tr sensor setting	300051	R/W	0=sensor on the wired wall pad 1=sensor on the main PCB; default:0
Reserved	300052	R/W	0-120, default:80
Optimized swing angle	300053	R/W	200-999 default:0;
E-heater	300054	R/W	Unit: KW*10
Room temp. factor	300055	R/W	90-120, default:103
Water inlet temp. factor	300056	R/W	90-120, default:103
Delt T factor	300057	R/W	90-120, default:102
Product type	300058	R/W	00-99; default:00
Product model	300059	R/W	000-999; default:000
Ex-works data	300060	R/W	0000—9999
Software version	300061	R	10-99 default:10
Hardware version	300062	R	10-99 default:10
Reserved	300063	R/W	
Reserved	300064	R/W	
Reserved	300065	R/W	
Reserved	300066	R/W	
Reserved	300067	R/W	
In auto mode, temp. Band setting	300068	R/W	1-15, default:3
Reserved	300069	R/W	
Reserved	300070	R/W	
Unit power input at High speed	300071	R/W	W*10
Unit power input at Med. speed	300072	R/W	W*10
Unit power input at Low speed	300073	R/W	W*10
Unit heat capacity at High speed	300074	R/W	KW*10
Unit heat capacity at Med. speed	300075	R/W	KW*10
Unit heat capacity at Low speed	300076	R/W	KW*10
Unit cool capacity at High speed	300077	R/W	KW*10
Unit cool capacity at Med. speed	300078	R/W	KW*10
Unit cool capacity at Low speed	300079	R/W	KW*10

* R = read only, W = write only, R/W = read and write.

Input Register table:

Description	Address	Type*	Remark
Tr temperature sensor	400000	R	
Ti1 temperature sensor	400001	R	
Ti2 temperature sensor	400002	R	
Reserved	400003	R	
Reserved	400004	R	
Error code	400005	R	Bit0 = Room temperature sensor error Bit1 = Ti1 temperature sensor error Bit2 = Ti2 temperature sensor error Bit3 = Float switch error Bit4 = Indoor coil low temperature protection Bit5 = Indoor coil over-heat protection Bit6 = Filter switch Bit7 = Electrical heater failure Bit8 = Motor1 Error Bit9 = Motor2 Error Bit10 = System parameters error Bit11 = Anti-frozen error Bit12 = Ti3 temperature sensor error Bit13 = Ti4 temperature sensor error Bit14 = PM2.5 sensor Bit15 = AQI Error
Fan speed status	400006	R	Low = 04(H) Medium = 02(H) High = 01(H)
Reserved	400007	R	
Reserved	400008	R	
EH	400009	R	0= disable, 1=booster, 2=primary
Unit type	400010	R	
DA1	400011	R	
DA2	400012	R	
Reserved	400013	R	
Reserved	400014	R	
Reserved	400015	R	
Reserved	400016	R	
Unit status	400017	R	Cooling mode = 01(H) Humidify mode = 02(H) Fan mode = 04(H) Heating mode = 08(H) Unit OFF=32(H)
Temperature in wall pad	400018	R	
Motor running time	400019	R	
Motor running terms	400020	R	0-100
Cooling capacity	400021	R	
Cooling capacity terms	400022	R	0-100
Heating capacity	400023	R	
Heat capacity terms	400024	R	0-100
Reserved	400025	R	
Reserved	400026-35	R	
EC motor1 actual RPM	400036	R	
EC motor2 actual RPM	400037	R	
EC motor1 error	400038	R	
EC motor2 error	400039	R	

* R = read only, W = write only, R/W = read and write.

D.4.2. Open Modbus Protocol For EC-S8

Transfer Mode: RTU, BAUD Rate: 9600bps, 8 data bit, 1 stop bit, None parity bit

The communications require a delay of 80ms between reading an answer and sending the next command. All temperatures are equal to reading data*10 accuracy: 0.1 degree C.

Supported Functions:

Function Code	Function Description
01(01H)	Read Coils
02(02H)	Read Discrete Inputs
03(03H)	Read Holding Registers
04(04H)	Read Input Registers
05(05H)	Write Single Coil
06(06H)	Write Single Register
15(0FH)	Write Multiple Coils
16(10H)	Write Multiple Registers
255(FFH)	Extended Commands which are used to test unit

Valid Error code table:

Error code	Description	Definition
01 (01H)	Invalid commands	Received commands beyond valid commands
02 (02H)	Invalid data address	Data addresses beyond valid data address
03 (03H)	Invalid data	Data beyond definition range
04 (04H)	Write data not successful	Write data did not succeed

Coils table:

Description	Address	Type*	Remark
ON/OFF	100000	R/W	
Sleeping mode	100001	R/W	
Louver swings	100002	R/W	
Energy Saving Mode	100003	R/W	
PRO function	100004	R/W	

Discrete table:

Description	Address	Type*	Remark
MTV1	200000	R	
MTV2	200001	R	
Reserved	200002	R	
Reserved	200003	R	
Condensate pump	200004	R	
Electrical heater	200005	R	
Wired wall pad	200006	R	
PR-O1	200007	R	
Float switch	200008	R	
Reserved	200009	R	
EH safety switch	200010	R	
Internal test	200011	R	Testing purpose only.
Reserved	200012	R	
Reserved	200013	R	
Reserved	200014	R	
Reserved	200015	R	
Reserved	200016	R	
Reserved	200017	R	
Reserved	200018	R	
Reserved	200019	R	

* R = read only, W = write only, R/W = read and write.

Holding Register table:

Description	Address	Type*	Remark
Mode setting	300000	R/W	Cooling mode = 01(H) Humidify mode = 02(H) Fan mode = 04(H) Heating mode = 08(H) Auto mode = 10(H)
Fan speed setting	300001	R/W	Low speed = 04(H) Medium speed = 02(H) High speed = 01(H) Auto fan speed = 07(H)
Louver swing setting	300002	R/W	Position 1=01(H)
			Position2=02(H)
			Position3=03(H)
			Position4=04(H)
			Auto=0F(H)
			Stop=00(H)
Setting temperature	300003	R/W	16-30 (actual*10 format)
Address setting	300004	R/W	1-255
Reset	300005	W	=0x33 reset error
Week	300006	W	
Hour	300007	W	
Minute	300008	W	
Second	300009	W	
Hours in Timer on	300010	R/W	Timer ON
Minute in Timer on	300011	R/W	Timer ON
Hours in Timer off	300012	R/W	Timer OFF
Minute in Timer off	300013	R/W	Timer OFF
Icon of Timer ON or OFF	300014	R/W	BIT0 = Icon of Timer ON BIT1 = Icon of Timer OFF 1 = enable 0 = disable
Minimum output DA1	300015	R/W	Default 25% (2.5vdc)
Minimum output DA2\DA3	300016	R/W	Default 25% (2.5vdc)
Pre-heat temperature setting	300017	R/W	25-35, default: 28
0-10vdc signal input setting	300018	R/W	Default: 40% (4VDC) or (10.4mA)
Super low speed rpm	300019	R/W	0-10V, default:2VDC
Low speed rpm	300020	R/W	1-10VDC, default: 3VDC
Medium speed rpm	300021	R/W	1-10VDC, default: 6VDC
High speed rpm	300022	R/W	1-10VDC, default: 8.5VDC
Signal output setting	300023	R/W	1-10VDC (used to test, 0 = disable)
Temperature sampling time	300024	R/W	2-100, default: 5S
Factor of auto fan speed	300025	R/W	2-150, default:20
Factor of modulating valve	300026	R/W	2-250, default:150
Ti1 and Ti2 difference setting	300027	R/W	3-15, default:5
Ti3 and Ti4 difference setting	300028	R/W	3-15 default:10
Controller Hardware type setting	300029	R/W	0=air cleaner (S5) 1=FCU (S1/S2/S3, SWC-S) 2=FCU (S8) or (S8+W5) Default:2
Degree unit setting	300030	R/W	0=degree C 1=degree F
Temperature display setting	300031	R/W	0=Room temperature display on LED 1=Setting temperature display on LED
Setting temperature range	300032	R/W	0=setting temperature range is from 16-30 1=Setting temperature range is fixed. Cooling=24oC, Heating=21oC
Temperature band setting	300033	R/W	1-9, default:1
Software type	300046	R/W	0=2-pipe with valve 1=4-pipe with std valve 2=4-pipe with 6-way valve

EH type	300047	R/W	0=without EH, 1=EH as booster; 2=EH as primary
DA1 control signal mode	300048	R/W	0=Tr/Ts 1=ESP
EC motor input ports	300049	R/W	0=CN4 working; 1=CN5 working 2=CN4+CN5 working default:0
PRO1 input type	300050	R/W	0=NO; 1=NC
Tr sensor setting	300051	R/W	0=sensor on the wired wall pad; 1=sensor on the main PCB; default:0
Reserved	300052	R/W	0-120, default:80
Reserved	300053	R/W	200-999 default:0
E-heater	300054	R/W	unit:KW*10
Room temp. factor	300055	R/W	90-120, default:103
Water inlet temp. factor	300056	R/W	90-120, default:103
Delt T factor	300057	R/W	90-120, default:102
Product type	300058	R/W	00-99; default:00
Product model	300059	R/W	000-999; default:000
Ex-works data	300060	R/W	0000—9999
Software version	300061	R	10-99 default:10
Hardware version	300062	R	10-99 default:10
EC motor1 Low RPM setting	300063	R/W	200rpm-1500rpm default:500
EC motor1 Maxi RPM setting	300064	R/W	200rpm-1500rpm default:1200
EC motor2 Low RPM setting	300065	R/W	200rpm-1500rpm default:500
EC motor2 Maxi RPM setting	300066	R/W	200rpm-1500rpm default:1200
EC motor qty setting	300067	R/W	0=EC motor1 working 1=EC motor2 working 2=EC motor 1/2 working default:2
In auto mode, temp. Band setting	300068	R/W	1-15, default:5
Reserved	300069	R/W	
Reserved	300070	R/W	
Unit power input at High speed	300071	R/W	W*10
Unit power input at Med. speed	300072	R/W	W*10
Unit power input at Low speed	300073	R/W	W*10
Unit heat capacity at High speed	300074	R/W	KW*10
Unit heat capacity at Med. speed	300075	R/W	KW*10
Unit heat capacity at Low speed	300076	R/W	KW*10
Unit cool capacity at High speed	300077	R/W	KW*10
Unit cool capacity at Med. speed	300078	R/W	KW*10
Unit cool capacity at Low speed	300079	R/W	KW*10
DA2 control mode	300080	R/W	0=based on delta T 1=based on water flow 2=based on signal input2
DA2 Chilled water flow setting	300081	R/W	0-4000L/h; default: 1020
DA2/DA3 heating water flow setting	300082	R/W	0-4000L/h; default: 1020
DA3 control signal mode	300083	R/W	0=based on delta T 1=based on water flow 2=based on signal input3
DA2 4-20mA input 2	300084	R/W	0-100, Default: 40%
DA2/DA3 4-20mA input 3	300085	R/W	0-100, Default: 40%

* R = read only, W = write only, R/W = read and write.

Input Register table:

Description	Address	Type*	Remark
Tr temperature sensor	400000	R	
Ti1 temperature sensor	400001	R	
Ti2 temperature sensor	400002	R	
Ti3 temperature sensor	400003	R	
Ti4 temperature sensor	400004	R	
Error code	400005	R	Bit0 = Room temperature sensor error Bit1 = Ti1 temperature sensor error Bit2 = Ti2 temperature sensor error Bit3 = Float switch error Bit4 = Indoor coil low temperature protection Bit5 = Indoor coil over-heat protection Bit6 = Filter switch Bit7 = Electrical heater failure Bit8 = Motor1 Error Bit9 = Motor2 Error Bit10 = System parameters error Bit11 = Anti-frozen error Bit12 = Ti3 temperature sensor error Bit13 = Ti4 temperature sensor error Bit14 = PM2.5 sensor Bit15 = AQI Error
Fan speed status	400006	R	Low = 04(H) Medium = 02(H) High = 01(H)
0-10VDC signal1	400007	R	
4-20mA signal2	400008	R	
EH	400009	R	0= disable, 1=booster, 2=primary
Unit type	400010	R	
DA1	400011	R	
DA2	400012	R	
DA3	400013	R	
Unit status	400017	R	Cooling mode = 01(H) Humidify mode = 02(H) Fan mode = 04(H) Heating mode = 08(H) Unit OFF=32(H)
Temperature in wall pad	400018	R	
Motor running time	400019	R	
Motor running terms	400020	R	0-100,
Cooling Capacity	400021	R	Unit: kWh
Cooling capacity terms	400022	R	0-100
Heating capacity	400023	R	Unit: kWh
Heating capacity terms	400024	R	0-100
EC motor1 actual RPM	400036	R	
EC motor2 actual RPM	400037	R	
EC motor1 error	400038	R	
EC motor2 error	400039	R	
Input signal (0-10Vdc)	400040	R	
Driver Temperature sensor	400041	R	
address	400042	R	
Reserved	400043	R	
water flow1	400044	R	m3/h
Water flow2	400045	R	m3/h
Cooling capacity	400046	R	
Heating capacity	400047	R	
4-20mA signal input3	400048	R	

* R = read only, W = write only, R/W = read and write

D.5. Modbus Network Setup for FCU group

Network Setup

1. Disconnect the communication plug from the control box



2. Communication plug

A, B, A, B is printed on the main PCB. When you connect the wires, please ensure connection of A to A and B to B.

3. Connection wire

3.1. If the total length of wire is more than 1000m, please use shielded wire in order to protect the signal transmission.

- 3.2. Complete wire connection

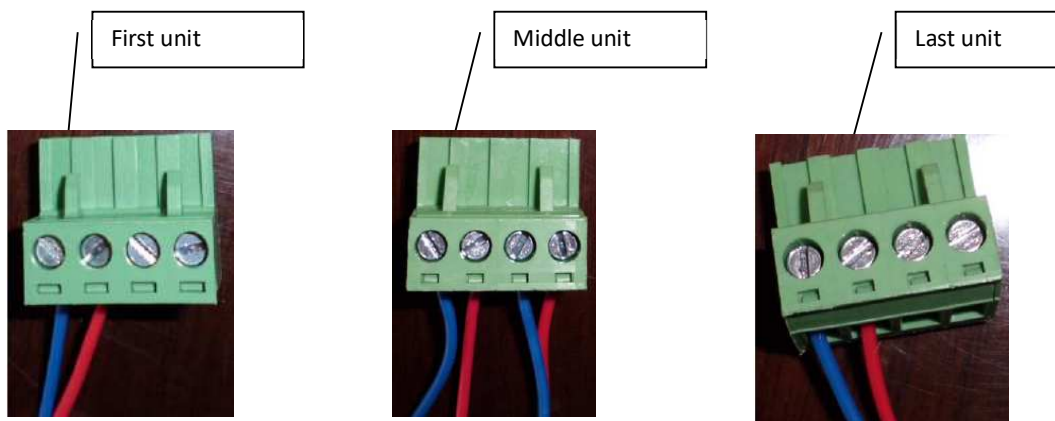
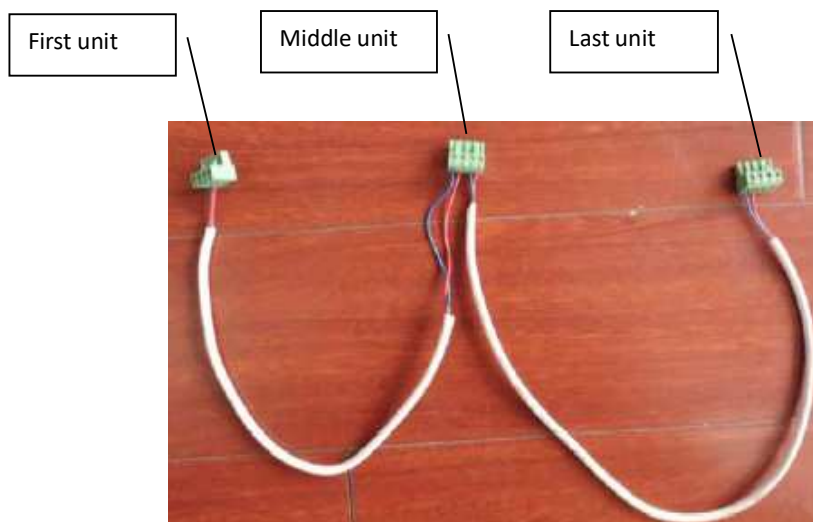

3.3. Wire connection check

3.3.1. After the wire connection is completed, please check that the wire colours correspond.

3.3.2. Check the wire contact by using a multimeter.

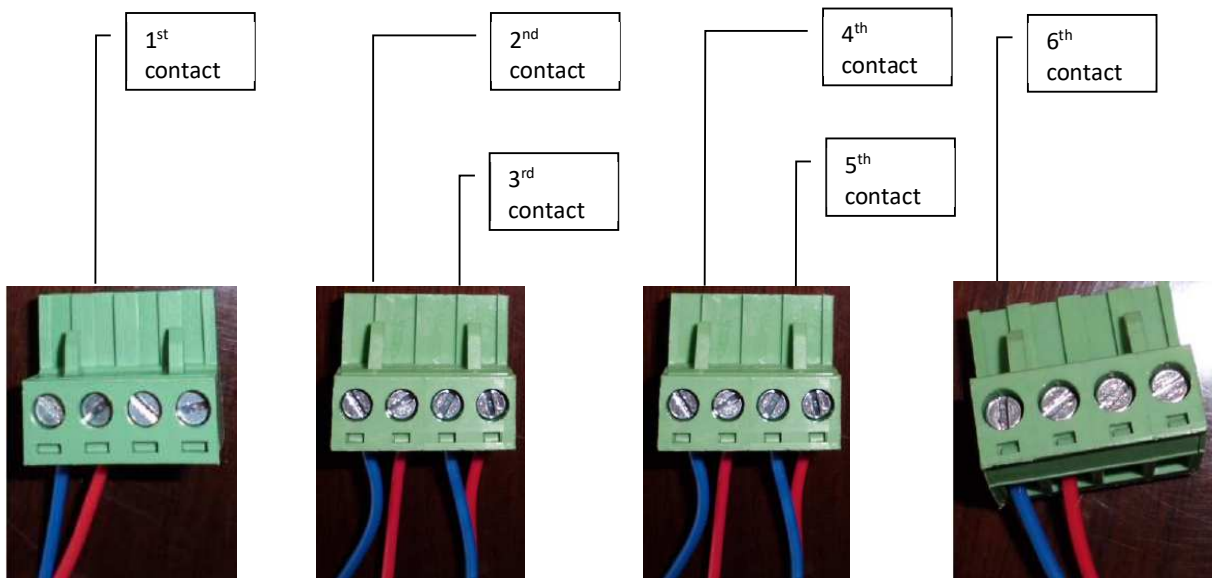

3.3.3. Check 1 and 2, 3 and 4, 5 and 6 to be sure connections are correct.

3.3.4. If the resistance between two wire contacts is too high, please check and reconnect the wire contacts.

4. Reconnect the communication plug to control box
5. Using wired wall pad or Modbus to set each unit address.

D.6. LED Indication and Error Description: I-Type (optional)

LED receiver in ABS housing with 0.5m or 1.8m pre-wiring



Complete Function PCB – I Type Control		
Fan speed setting	LED indication	Condition
High speed	Red LED On	Normal
Medial speed	Yellow LED On	Normal
Low speed	Green LED On	Normal

For all units - Green LED			
Error Description	Blink	Reason	Remedy
Return air sensor failure	Green LED blinks 1 times, stops for 3s	Room sensor unplugged or damaged.	1. Check if Tr plug is connected or not. 2. Check if sensor's resistance is correct or not.
Indoor coil sensor 1 failure	Green LED blinks 2 times, stops for 3s	Ti1 sensor unplugged or damaged.	1. Check if Ti1 plug is connected or not. 2. Check if sensor's resistance is correct or not.
Indoor coil sensor ² failure	Green LED blinks 3 times, stops for 3s	Ti2 sensor unplugged or damaged.	1. Check if Ti2 plug is connected or not. 2. Check if sensor's resistance is correct or not.
Water pump failure	Green LED blinks 4 times, stops for 3s	Float switch is opened.	1. Check if the condensate water pipe is connected or not. 2. Check if the pump is functioning or not.
Indoor coil low temperature protection	Green LED blinks 5 times, stops for 3s	Water temperature is lower than 3 °C.	Check the water temperature.
Indoor coil over heat protection	Green LED blinks 6 times, stops for 3s	Water temperature is higher than 70 °C.	Check the water temperature
Filter Switch (S6 PCB)	Green LED blinks 7 times, stops for 3s	Filter switch is opened.	1. Check if filter block or not 2. replace the new filter
Electric Heater failure	Green LED blinks 8 times, stops for 3s	Only for unit with EH. EH safety switch is opened.	1. Change fan speed to high. 2. Replace the damaged EH safety switch.
EC motor failure (CN4)	Green LED blinks 9 times, stops 3s	No EC motor feedback	1. Check Modbus setting. 2. Check the EC motor.
EC motor failure (CN5)	Green LED blinks 10 times, stops 3s	No EC motor feedback	1. Check Modbus setting. 2. Check the EC motor.
Anti-frozen protection	Green LED blinks 12 times, stops for 3s	When unit is standby, Tr<2°C.	1. Turn on unit to keep Tr high than 5°C

E. Control Specifications: Flexible Function (W TYPE)

E.1. I/O Port Definitions for W type

E.1.1. I/O Port Definitions for W3

I/O		Code	Descriptions
Analogue input	Coil temperature sensor	AI1	Cooling / heating coil sensor (Ti1)
Voltage input	High fan speed	H	230 VAC input signals from wired thermostat
	Medium fan speed	M	
	Low fan speed	L	
	EH signal	EH	230 VAC input signals from wired thermostat (W1-Used it)
	Live	L1	External 230VAC power supply connection to the PCB
	Neutral	N1, N2	
Earth	GND		
Signal Input	Modulating signal	+/-	Low voltage modulating signal input (standard 0~5 VDC, S1=OPEN, optional 0~10 VDC, S1=CLOSED)
Digital input	Float switch	Float	Voltage free (NC)
Voltage output	Water pump	PUMP	Voltage output (L)
	EC motor1	CN3	5-wire connection
	EC motor2	CN4	5-wire connection
	Stepping motor	CN1, CN2	Low-voltage output (W1-used it)
	EH Relay	CN5	When EH signal input is powered on and EC motor RPM>300 RPM, EH output is turned on (W1-Used it)
Digital output	LED display	X-DIS	Low-voltage output
Voltage-free output	Alarm	ALARM	Voltage-free alarm contact: (a) Standard configuration is (NC).
Communication port	Modbus Port	A, B	Modbus Protocol

E.1.2. I/O Port Definitions for EC-W4/W5

I/O		Code	Descriptions
Voltage input	Live	L1	External 230VAC power supply connection to the PCB
	Neutral	N1	
	Earth	GND	
Signal Input	Modulating signal1	+/-	Low voltage modulating signal input (0~10Vdc)
Voltage output	DC motor 1	U, V, W	3-wire connection for DC motor1
	DC motor 2	U1, V1, W1	3-wire connection for DC motor2 only for W5
Communication port	Modbus Port	A, B	Modbus Protocol

E.2. Wiring Diagram for W Type

EC-W3 Wiring Diagram

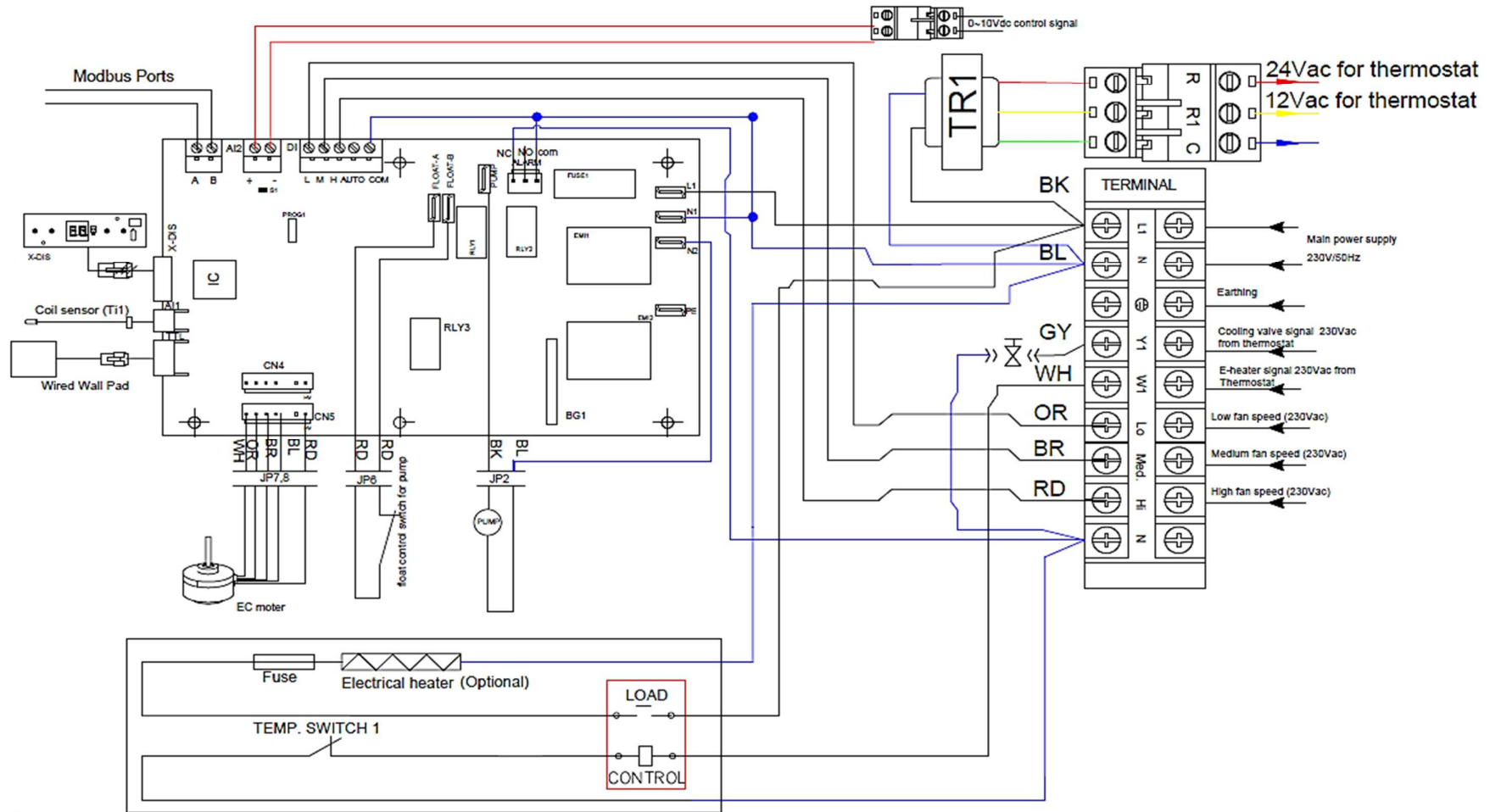

Legend:

AI1: Indoor coil sensor(TI1)
 AI2: 0~10VDC ,EC Motor control signal.
 X-DIS: Led display;
 TTL: Wired wall pad

ALARM: Pump or motor failure ,it's opened. V1 and EH stop work.
 PUMP: Water pump output
 CN4, CN5: EC motor output

Wiring Diagram for PDWD-1000~1800-EC

EC-W4 Wiring Diagram

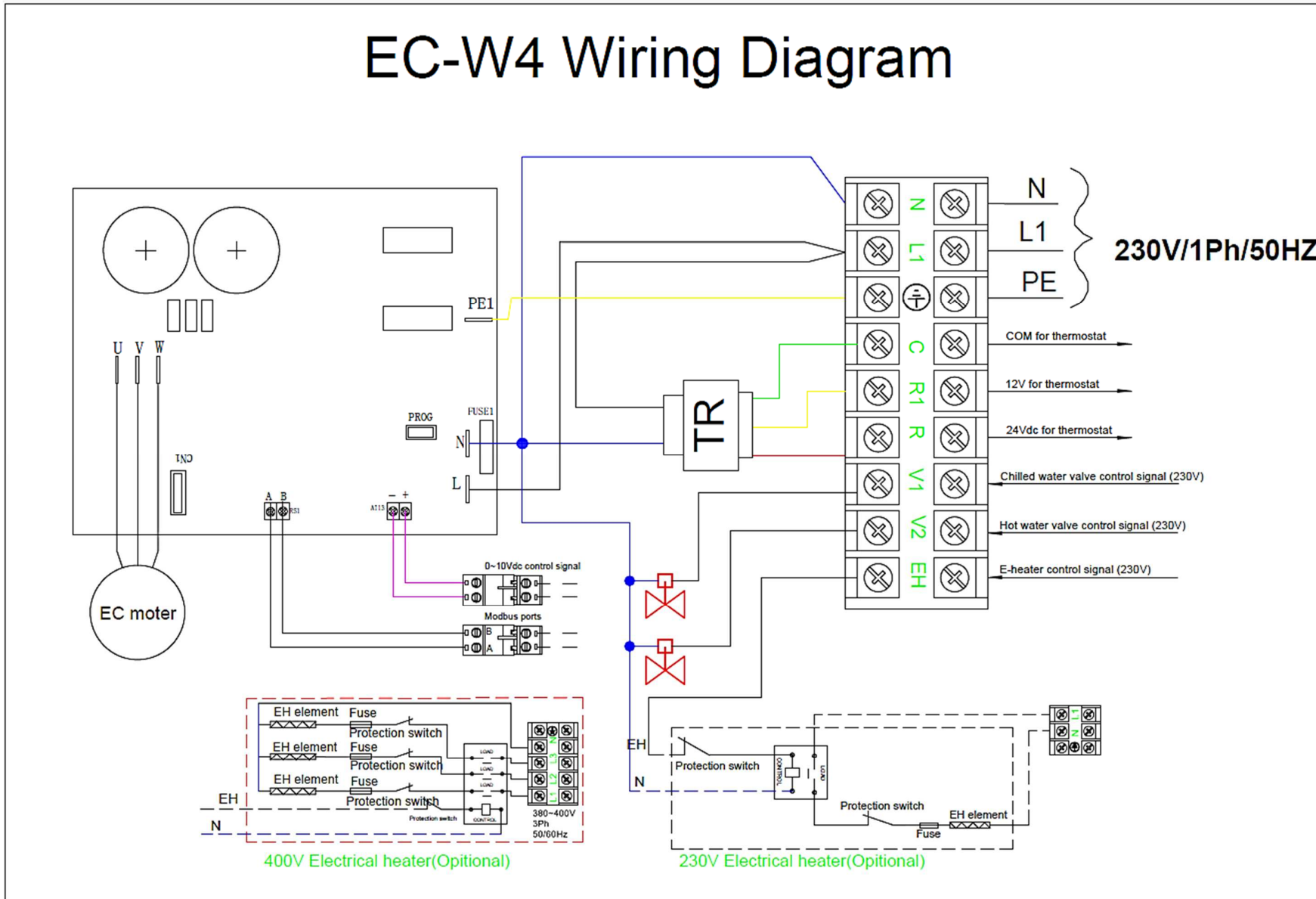

EC-W5 Wiring Diagram

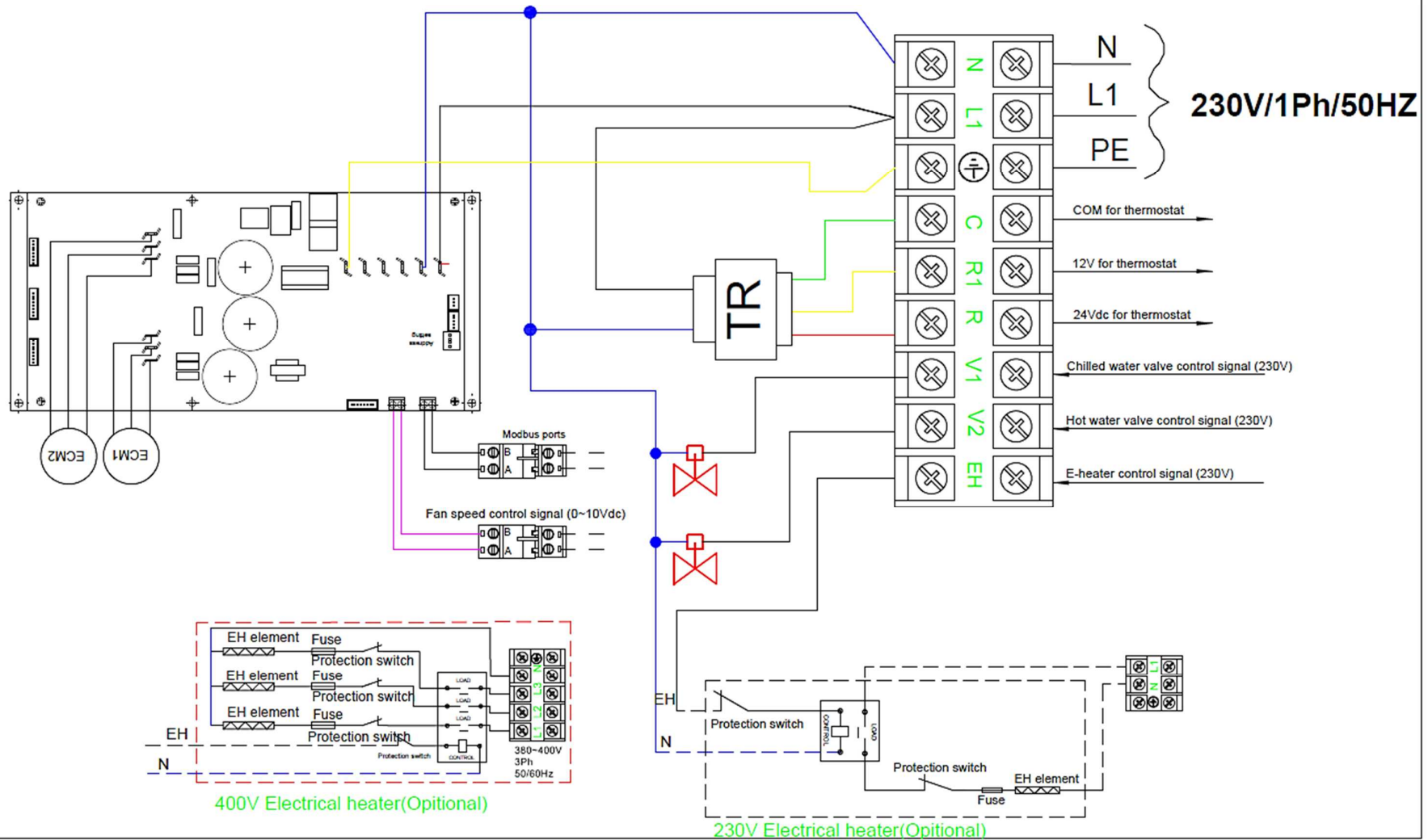

E.3. Control Logic Specification for W Control

E.3.1. Control Logic Specification for W3 Control

Unit Power ON/OFF

- a) The unit is turned ON when any of the fan speed inputs (H/M/L) is ON or motor signal input is more than 2Vdc.
- b) The unit is turned OFF only if all of the fan speed inputs (H/M/L) are OFF and motor signal input is less than 2Vdc.

Alarm Protection and Error Display

- a) If float switch is opened for 5 minutes or EC motor is failed, voltage-free (NC) alarm contact will be opened and voltage free (NO) alarm contact will be closed.
- b) If float switch is opened for 10 minutes or EC motor is failed, LED display reports a condensate management failure (see table on the next page).

Modulating Signal Input

- a) The standard configuration is for 0~5VDC motor control signal input.
- b) The optional configuration is for 0~10VDC motor control signal input. Close the S1 jumper to set it.

Electrical Heater Operation

- a) After unit is turned on, EH relay will be ON when EH signal is power on and EC motor RPM>300
- b) If EC motor failure or EC motor RPM is lower than 300RPM, EH relay is opened at once.

Low Temperature Protection of Indoor Coil in Winter

This is frost protection when the unit is off to prevent water in the coil and room from freezing.

When unit is in Standby Mode, if $Ti1 \leq 2^{\circ}\text{C}$ for 2 minutes, it reports error code and the buzzer beeps.

E.3.2. Control Logic Specification for W4/5 Control

The unit is turned ON when modulating signal input is more than 2.0VDC or Modbus 300006 and 300007 settings;

The unit is turned OFF when modulating signal input is less than 2.0VDC and Modbus 300006 and 300007 settings.

E.4. Open Modbus Protocol

E.4.1. Open Modbus Protocol for W3

Transfer Mode:RTU BAUD Rate:9600bps, 8 data bit, 1 stop bit, None parity bit

The communications require a delay between reading an answer and sending the next command of 80 ms.

Holding Register table

Description	Address	Type*	Remark
Motor1 minimum RPM (CN4 Port)	30000	R/W	200~1500rpm700
Motor1 maximum RPM (CN4 Port)	30001	R/W	200~1500rpm
Motor2 minimum RPM (CN5 Port)	30002	R/W	200~1500rpm
Motor2 maximum RPM (CN5 Port)	30003	R/W	200~1500rpm1350
Motor qty setting	30004	R/W	0=EC motor1 working 1=EC motor2 working 2=EC motor 1/2 working default: 2
Reserved	30005	R/W	
Motor1 RPM writing	30006	R/W	MS30006=0~200, Motor1 works according to signal input1; MS30006=above 200, Motor1 RPM is according to RPM writing.
Motor2 RPM writing	30007	R/W	MS30007=0~200, Motor2 works according to signal input1; MS30007=above 200, Motor2 RPM is according to RPM writing.
Unit Address setting	30008	R/W	1~15; Default: 55
High speed RPM setting	30009	R/W	200~1500rpm 1300rpm
M- speed RPM setting	30010	R/W	200~1500rpm 1100rpm
L-speed RPM setting	30011	R/W	200~1500rpm 900rpm
Anti-frozen protection setting	30012		0=able; 1=disable, Default:0
Optimized swing angle	30013	R/W	200~999, default:0;

Input Register table:

Description	Address	Type*	Remark
EC motor1 actual RPM	40000	R	
EC motor2 actual RPM	40001	R	
EC motor1 error	40002	R	
EC motor2 error	40003	R	
Input signal1 (0~10Vdc)	40004	R	
Reserved	40005	R	
Condensate pump	40006	R	
Electrical heater	40007	R	
Ti1	40008	R	
Wired wall pad	40009	R	
Hi-speed input	40010	R	
M-speed input	40011	R	
L-speed input	40012	R	
Float switch input	40013	R	
EH safety switch input	40014	R	
Alarm output	40015	R	
ERR Code	40016	R	
Software Version	40017	R	3202201202

E.4.2. Open Modbus Protocol for W4/W5

Transfer Model: RTU BAUD Rate:9600bps, 8 data bit, 1 stop bit, None parity bit

The communications require a delay between reading an answer and sending the next command of 80ms.

Holding Register table

Description	Address	Type*	Remark
Motor1 minimum RPM (U,V,W port)	30000	R/W	200~1500rpm
Motor1 maximum RPM (U,V,W port)	30001	R/W	200~1500rpm
Motor2 minimum RPM (U1,V1,W1 port)	30002	R/W	200~1500rpm
Motor2 maximum RPM (U1,V1,W1 port)	30003	R/W	200~1500rpm
Motor qty setting	30004	R/W	0=EC motor1 working 1=EC motor2 working 2=EC motor 1/2 working W4-only set 0; W5/W6, default:=2
Signal inputs setting for W6	30005	R/W	0=Signal input 1 works; Motor 1/2 works based on signal input1. 1=Signal input2 works; Motor 1 works based on signal input1. Motor 2 works based on signal input2. Default:0
Motor1 RPM writing	30006	R/W	MS30006=0~200, Motor1 works according to signal input1; MS30006=above 200, Motor1 RPM is according to RPM writing.
Motor2 RPM writing	30007	R/W	MS30007=0~200, Motor2 works according to signal input2; MS30007=above 200, Motor2 RPM is according to RPM writing.
Unit Address setting	30008	R	1~15; Set by Dip-switch Default: 55

Input Register table:

Description	Address	Type*	Remark
EC motor1 actual RPM	40000	R	
EC motor2 actual RPM	40001	R	
EC motor1 error	40002	R	
EC motor2 error	40003	R	
Input signal1 (0~10Vdc)	40004	R	
Input signal2 (0~10Vdc)	40005	R	
Software Version	40017	R	

F. User Interface

F.1. Remote Handset for I Type Control

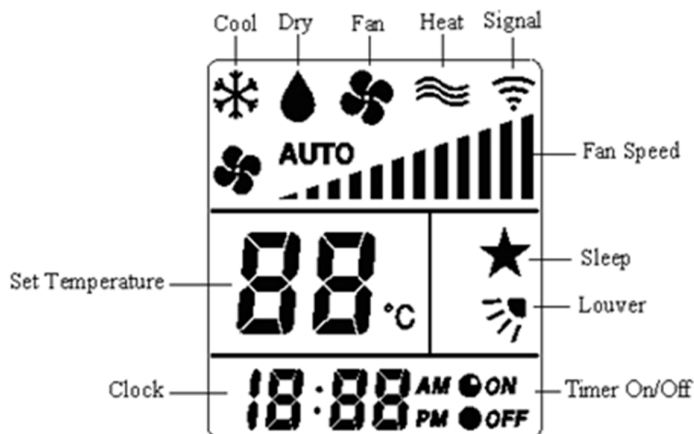
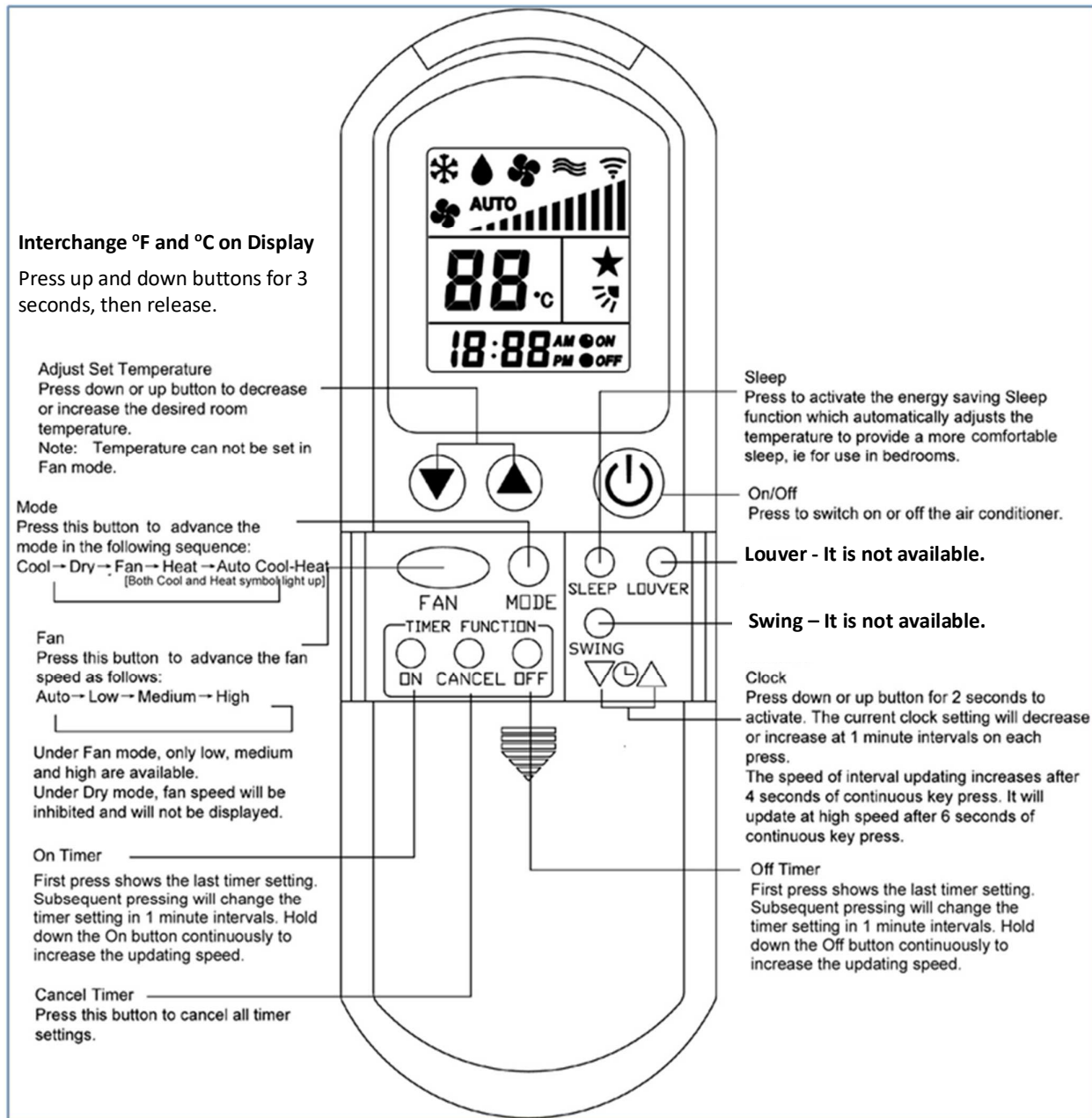

Attention

When unit with handset is master, settings are automatically sent to slaves;
Auto Cool-Heat operation will be applicable in 4-pipe system only.

“Louver” and “Swing” are not applicable.



























F.2. Wired Wall Pad Controller for I-Control

F.2.1. LED display



Code	Legend	Code	Legend	Code	Legend
S1	Monday	S14	Heating Mode	S27	Fahrenheit degree
S2	Tuesday	S15	Ventilation Mode	S28	Celsius degree
S3	Wednesday	S16	Auto Mode	S29	Fan
S4	Thursday	S17	Sleep mode	S30	0-Auto; 1-Low; 2-Medium; 3-High
S5	Friday	S18	Swing mode	S31	Unit address
S6	Saturday	S19	LED lock	S32	Unit No. / Error code
S7	Sunday	S20	Setting Temperature	S33	Weekly timer
S8	Timer-ON	S21	Room Temperature	S34	C-cooling
S9	Timer-ON time Normally: Real time	S22	RH (if need)	S35	H-heating
S10	Timer-OFF	S23	CO2 density (if need)	S36	Energy consumption
S11	Timer-OFF time	S24	PM2.5 density (if need)	S37	Energy consumption cycle
S12	Cooling Mode	S25	Data Display		
S13	Dehumidification	S26	RH percentage		
S38	On/Off Button	S40	Fan speed setting	S42	Up
S39	Mode setting	S41	Parameter setting	S43	Down

F.2.2. Operation guide

S38	On/OFF Button	Press  to turn on. Press it again to turn off.
S39	Mode button	With wall pad on, press  to select Cooling, Dehumidification, Heating, Ventilation or Auto sequentially.or Auto sequentially.
S40	Fan Speed Button	Press  S30 to change from 0 to3. 0=Auto speed, 1=Low speed, 2=Medium speed, 3=High speed.
S41	Parameter Setting Button	Long press  for 5 seconds to set today's day of week. Press  or  to change from Monday to Sunday.
		Long press  for 5 seconds then short press it once to set current time. Press  or  to change current time.
		Long press  for 5 seconds then short press it twice to set Timer ON. Press  to set day of week from Monday to Sunday. Press  or  to change Timer ON time. Press  to turn Timer ON on or off and S8 appears or disappears.
		Long press  for 5 seconds then short press it 3 times to set Timer OFF time. Press  to set day of week from Monday to Sunday. Press  or  to change Timer OFF time. Press  to turn Timer OFF on or off and S10 appears or disappears.
		Long press  for 5 seconds then short press it 4 times to set group control and U31 appears. The function is reserved.
		Long press  for 5 seconds then short press it 5 times to set unit address and U32 appears. Press  or  to change unit address.
		Long press  for 5 seconds then short press it 6 times to set unit parameters. Press  to change the parameter type. Press  or  to change parameter setting value.

*** For MODBUS user only

S31/S32 displays "U001", which is used to set unit type.
0=iAIR Mode: Ventilation T, RH, CO2, PM2.5 are displayed.
1=iFCU Mode: S12, S13, S14, S15, S16, S21 or S20 is displayed.
2=iAHU Mode: S12, S13, S14, S15, S16, S21 or S20 is displayed.
3=iAHU with air cleaner Mode: S12, S13, S14, S15, S16, T, RH, CO2, PM2.5 are displayed.

S31/S32 displays "U002", which is used to set unit of temperature degree.
0=Celsius degree.
1=Fahrenheit degree.

S31/S32 displays "U003", which is used to select display temperature on LCD.
1=Setting temperature.

0=Room temperature.

S31/S32 displays "U004", which is used to set setting temperature range.

0=Setting temperature is from 16~30°C.

1=Cooling setting temperature 24°C, Heating setting temperature 21°C.

S31/S32 displays "U005", which is used to set setting temperature band.

1~9°C.

S31/S32 displays "U006-U009", which are reserved to set parameters with optional accessory to measure PM2.5 and CO2 values.

S31/S32 displays "U010~U011", which are reserved.

S31/S32 displays "U012", which is used to set setting RH point.

30~70, default: 50

S31/S32 displays "U013", which is used to set setting RH band.

10~30, default: 10

S31/S32 displays "U014", which is used to set unit address.

1~255, default: 1

S31/S32 displays "U015", which is used to set unit ESP.

0~100%, default: 40%

S31/S32 displays "U016", which is reserved.

S31/S32 displays "U017", which is used to set software. (please refer to different PCB)

0=2-pipe with valve

1=2-pipe without valve

2=4-pipe with std valve

3=4-pipe with 6-way

valve

S31/S32 displays "U018", which is reserved.

S31/S32 displays "U019", which is used to set DA1 function

When U001=2,3

U019=0, fan control signal is based on Tr, Ts PID calculation

U019=1, fan control signal is based on ESP PID calculation

S31/S32 displays "U020", which is used to calibrate the sensor on the wired wall pad.

-5~5, default: -3

S31/S32 displays "U021", which is used to set EH function

U021= 0, without EH.

U021= 1, EH as booster.

U021=2, EH as primary.

S31/S32 displays "U022", which is used to select Tr sensor.

0=the sensor in the WWP.

1=the sensor in the PCB.

S31/S32 displays "U023", which is used to display cooling and heating energy consumption.







0=S34/S35/S36/S37 disappears

1=S34/S35/S36/S37 appears

In cooling and dehumidification mode, cooling energy consumption is shown.

In heating mode, heating energy consumption is shown.

2=Motor running time is shown.

		<p>S31/S32 displays “U024”, which is used to set low speed RPM or control signal.</p> <p>S31/S32 displays “U025”, which is used to set medium speed RPM or control signal.</p> <p>S31/S32 displays “U026”, which is used to set high speed RPM or control signal.</p> <p>S31/S32 displays “U027”, which is used to set Delta T OF Ti1/Ti2.</p> <p>S31/S32 displays “U028”, which is used to set Delta T OF Ti3/Ti4.</p> <p>S31/S32 displays “U029”, which is used to read unit type.</p> <p>S31/S32 displays “U030”, which is used to read unit model.</p> <p>S31/S32 displays “U031”, which is used to read unit manufacturing date.</p>
S32	Error code	<p>S32 : E** blinks</p> <p>Bit0 = Room temperature sensor error</p> <p>Bit1 = Ti1 temperature sensor error</p> <p>Bit2 = Ti2 temperature sensor error</p> <p>Bit3 = Float switch error</p> <p>Bit4 = Indoor coil low temperature protection</p> <p>Bit5 = Indoor coil overheat protection</p> <p>Bit6 = Filter switch</p> <p>Bit7 = Electrical heater failure</p> <p>Bit8 = Motor1 Error</p> <p>Bit9 = Motor2 Error</p> <p>Bit10 = System parameters error</p> <p>Bit11 = Anti-frozen error</p> <p>Bit12 = Ti3 temperature sensor error</p> <p>Bit13 = Ti4 temperature sensor error</p> <p>Bit14 = PM2.5 sensor error</p> <p>Bit15 = AQI Error</p>
Combination Button Function	Screen Lock Function	<p>Long press  for 5 seconds, S19 appears and screen is locked.</p> <p>Long press  for 5 seconds again, S19 disappears and screen is unlocked.</p>
	Swings Function	<p>Long press  for 5 seconds, S18 appears and swings is ON.</p> <p>Long press  for 5 seconds again, S18 disappears and swings is OFF.</p>
	Sleep Mode	<p>Long press  for 5 seconds, S17 appears and sleep mode is ON.</p> <p>Long press  for 5 seconds again, S17 disappears and sleep mode is OFF.</p>

F.2.3. Error Code List

Error Description	Code	Reason	Remedy
Room temperature sensor error	E1	Room sensor unplugged or damaged.	1. Check if Tr plug is connected or not. 2. Check if sensor's resistance is correct or not.
Indoor coil sensor 1 failure	E2	Ti1 sensor unplugged or damaged.	1. Check if Ti1 plug is connected or not. 2. Check if sensor's resistance is correct or not.
Indoor coil sensor 2 failure	E3	Ti2 sensor unplugged or damaged.	1. Check if Ti2 plug is connected or not. 2. Check if sensor's resistance is correct or not.
Float switch error	E4	Float switch is opened.	1. Check if the condensate water pipe is connected or not. 2. Check if the pump is functioning or not.
Indoor coil low temperature protection	E5	Water temperature is lower than 3 °C.	Check the water temperature.
Indoor coil over-heat protection	E6	Water temperature is higher than 70 °C.	Check the water temperature
Filter switch protection	E7	Filter Switch is open.	Replace or clean filter.
Electric Heater failure	E8	Only for unit with EH. EH safety switch is opened.	1. Change fan speed to high. 2. Replace the damaged EH safety switch.
EC motor failure(CN4)	E9	No EC motor feedback	1. Check Modbus setting. 2. Check the EC motor.
EC motor failure(CN5)	E10	No EC motor feedback	1. Check Modbus setting. 2. Check the EC motor.
Motor qty setting error (S6 PCB)	E11	Motor Qty setting error	1: check Modbus setting
Anti-frozen protection	E12	When unit is standby, Tr<2°C.	1. Turn on unit to keep Tr high than 5°C
Indoor coil sensor 3 failure (S6 PCB)	E13	Ti3 sensor unplugged or damaged.	1. Check if Ti3 plug is connected or not. 2. Check if sensor's resistance is correct or not.
Indoor coil sensor 4 failure (S6 PCB)	E14	Ti4 sensor unplugged or damaged.	1. Check if Ti4 plug is connected or not. 2. Check if sensor's resistance is correct or not.
PM2.5 sensor failure (S6 PCB)	E15	PM2.5 sensor unplugged or damaged.	1. Check if PM2.5 plug is connected or not. 2. Check if sensor's resistance is correct or not.
AQI sensor failure (S6 PCB)	E16	AQI sensor unplugged or damaged.	1. Check if AQI plug is connected or not. 2. Check if sensor's resistance is correct or not.
Wired Wall Pad failure	E17	WWP unplugged or not well	Check plugs

F.2.4. Dimensions and installation

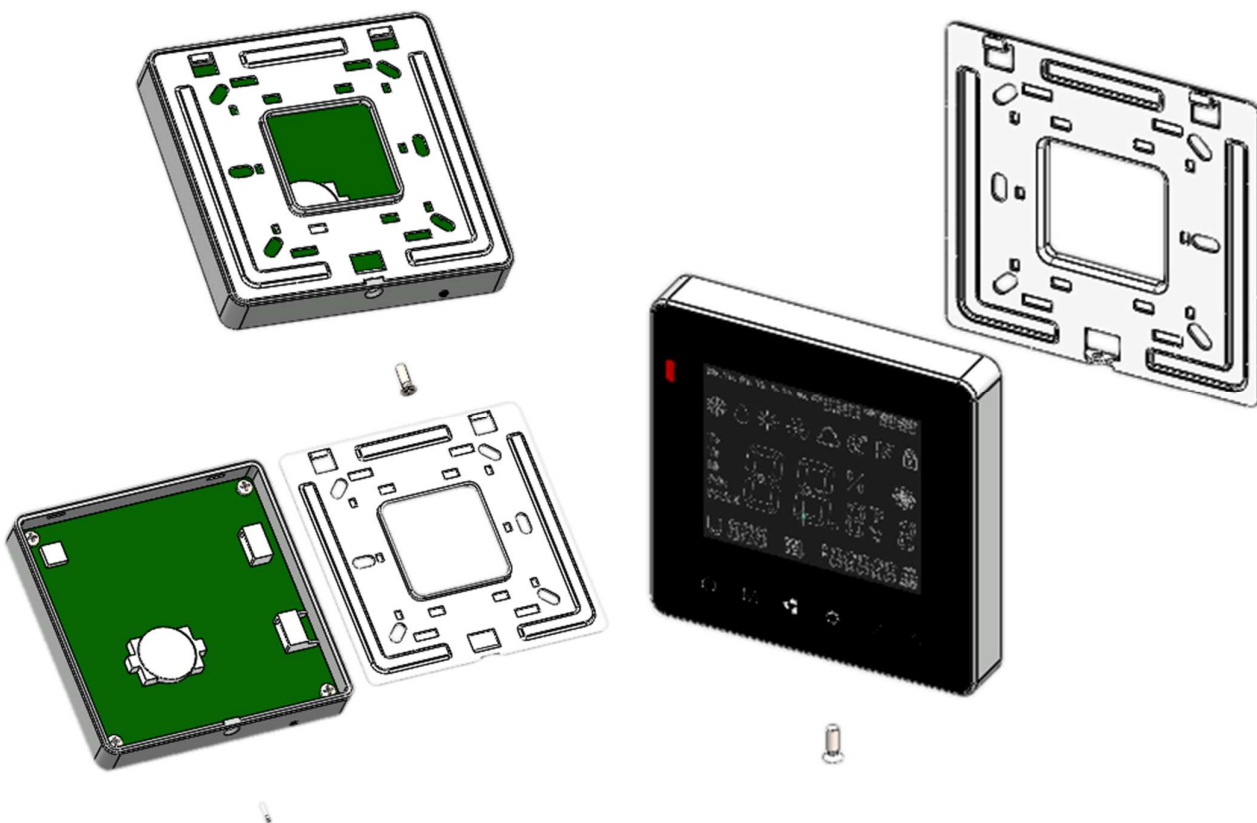
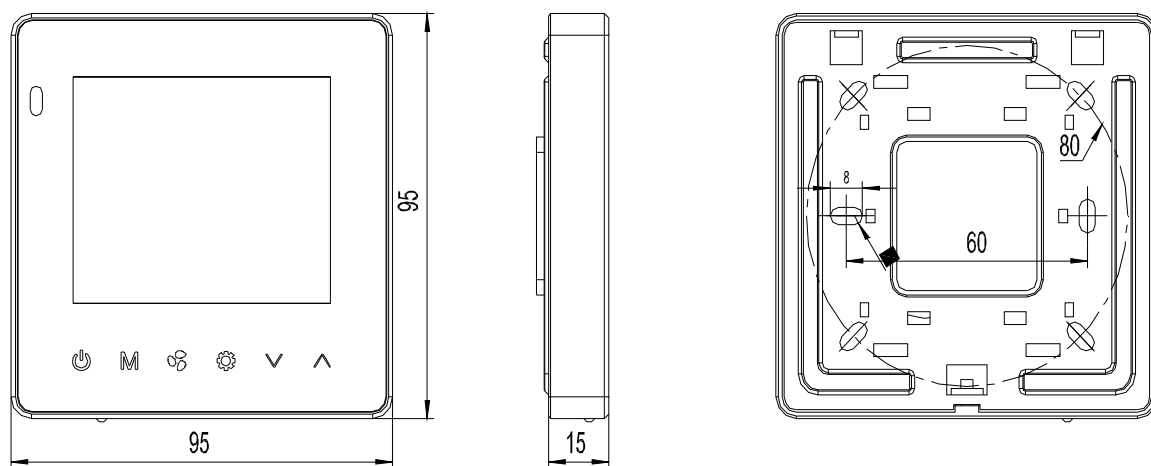

1. Remove the screw on the bottom and remove the back connection panel.

2. Fix the back panel to wall and then connect the Display on the back panel.

G. Sensor Resistance R-T Conversion Table

Resistance: $R(25^{\circ}\text{C}) = 10\text{K}\Omega \pm 1\%$ Beta Constant: $B(25/85) = 3977 \pm 1\%$

T (°C)	Rmin (KΩ)	Rnom (KΩ)	Rmax (KΩ)	T (°C)	Rmin (KΩ)	Rnom (KΩ)	Rmax (KΩ)
-30	174	182.7	191.8	4	26.11	26.9	27.71
-29	163.4	171.5	179.9	5	24.85	25.59	26.34
-28	153.6	161.1	168.9	6	23.65	24.35	25.05
-27	144.4	151.3	158.5	7	22.52	23.17	23.83
-26	135.8	142.2	148.9	8	21.45	22.06	22.68
-25	127.8	133.8	140	9	20.44	21.01	21.59
-24	120.3	125.8	131.6	10	19.48	20.02	20.55
-23	113.3	118.4	123.8	11	18.58	19.7	19.58
-22	106.7	111.5	116.5	12	17.71	18.18	18.65
-21	100.6	105.1	109.7	13	16.9	17.33	17.77
-20	94.9	99.03	103.3	14	16.12	16.53	16.94
-19	89.51	93.39	97.41	15	15.39	15.77	16.16
-18	84.5	88.11	91.85	16	14.69	15.05	15.41
-17	79.8	83.17	86.64	17	14.03	14.37	14.7
-16	75.39	78.53	81.76	18	13.41	13.72	14.03
-15	71.26	74.18	77.19	19	12.81	13.1	13.4
-14	67.37	70.1	72.9	20	12.24	12.52	12.79
-13	63.73	66.26	68.88	21	11.7	11.96	12.22
-12	60.3	62.67	65.1	22	11.19	11.43	11.67
-11	57.08	59.28	61.55	23	10.71	10.93	11.15
-10	54.05	56.1	58.22	24	10.24	10.45	10.66
-9	51.19	53.12	55.08	25	9.8	10	10.2
-8	48.51	50.3	52.14	26	9.374	9.57	9.765
-7	45.98	47.66	49.37	27	8.969	9.16	9.351
-6	43.61	45.17	46.77	28	8.584	8.77	8.957
-5	41.36	42.82	44.31	29	8.218	8.4	8.582
-4	39.25	40.61	42	30	7.869	8.047	8.225
-3	37.26	38.53	39.83	31	7.537	7.71	7.885
-2	35.38	36.56	37.78	32	7.221	7.39	7.56
-1	33.6	34.71	35.85	33	6.92	7.085	7.251
0	31.93	32.97	34.02	34	6.633	6.794	6.956
1	30.35	31.32	32.3	35	6.36	6.517	6.675
2	28.85	29.76	30.68	36	6.099	6.252	6.407
3	27.44	28.29	29.15	37	5.85	6	6.151

T (°C)	Rmin (KΩ)	Rnom (KΩ)	Rmax (KΩ)	T (°C)	Rmin (KΩ)	Rnom (KΩ)	Rmax (KΩ)
38	5.614	5.759	5.907	75	1.417	1.474	1.532
39	5.387	5.53	5.673	76	1.37	1.426	1.482
40	5.172	5.31	5.451	77	1.326	1.379	1.434
41	4.966	5.101	5.238	78	1.282	1.335	1.389
42	4.769	4.901	5.034	79	1.241	1.292	1.344
43	4.582	4.71	4.84	80	1.201	1.25	1.302
44	4.402	4.527	4.654	81	1.162	1.211	1.261
45	4.231	4.353	4.477	82	1.125	1.172	1.221
46	4.067	4.186	4.307	83	1.089	1.135	1.183
47	3.911	4.027	4.144	84	1.055	1.1	1.146
48	3.761	3.874	3.989	85	1.021	1.065	1.111
49	3.618	3.728	3.84	86	0.9891	1.032	1.077
50	3.481	3.588	3.697	87	0.9582	1	1.044
51	3.35	3.454	3.561	88	0.9284	0.9697	1.012
52	3.225	3.326	3.43	89	0.8998	0.9401	0.9818
53	3.105	3.204	3.305	90	0.8721	0.9115	0.9522
54	2.99	3.086	3.185	91	0.8455	0.8839	0.9237
55	2.88	2.974	3.07	92	0.8198	0.8573	0.8961
56	2.774	2.866	2.959	93	0.795	0.8316	0.8696
57	2.673	2.762	2.854	94	0.7711	0.8069	0.8439
58	2.576	2.663	2.752	95	0.748	0.783	0.8192
59	2.483	2.568	2.655	96	0.7258	0.7599	0.7953
60	2.394	2.477	2.562	97	0.7043	0.7376	0.7722
61	2.309	2.39	2.472	98	0.6836	0.7161	0.7499
62	2.227	2.306	2.386	99	0.6635	0.6953	0.7283
63	2.149	2.225	2.304	100	0.6442	0.6752	0.7075
64	2.073	2.148	2.224	101	0.6255	0.6558	0.6874
65	2.001	2.074	2.148	102	0.6075	0.6371	0.6679
66	1.931	2.002	2.075	103	0.59	0.619	0.6491
67	1.865	1.934	2.005	104	0.5732	0.6015	0.631
68	1.801	1.868	1.937	105	0.5569	0.5846	0.6134
69	1.739	1.805	1.872				
70	1.68	1.744	1.81				
71	1.623	1.686	1.75				
72	1.569	1.63	1.692				
73	1.516	1.576	1.637				
74	1.466	1.524	1.583				

H. Troubleshooting

Symptoms	Cause	Remedy
The fan coil does not start up	No voltage	Check for presence of voltage Check fuse on board
	Mains switch in the "OFF" position	Place in the "ON" position
	Faulty room control	Check the room control
	Faulty fan	Check fan motor
Insufficient output	Filter clogged	Clean the filter
	Air flow obstructed	Remove obstacles
	Room control regulation	Check the room air sensor
	Incorrect water temperature	Check the water source
	Air present	Check the air vent
Noise and vibrations	Contact between metal parts	Check for loosening parts
	Loose screws	Tighten screws



Note: All the information or data in this manual may be changed without notice.

EUROPE

C / Rio Jucar, Nave 6 P.I El Saladar
Lorquí; Murcia, Spain 30564
Ph: (+34) 968 046 262

ASIA

6 On Ping St, R.6 - Block A, 9th Floor,
New Trade Plaza, Shatin, Hong Kong
Ph: (+852) 2648 8887

www.pghvac.com

contact@pghvac.com